

# AERECO, AIR ON DEMAND





**Everyone knows** that air quality is a decisive factor when it comes to comfort at home and in the office. Additionally, modern building regulations make cutting energy costs a major priority. Aereco has been meeting these demands by designing and manufacturing innovative demand controlled ventilation systems for 30 years since it invented the humidity sensitive ventilation system in 1984.

**Today, Aereco continues to pursue its research,** consistently offering new intelligent ventilation solutions that are adapted to the specific needs of dwellings and office buildings. The humidity sensitive ventilation process is a landmark in demand controlled ventilation systems. It has bestowed upon Aereco and its products an image that guarantees quality and technical know-how, making Aereco a formidable player in the ventilation sector the world over. In conjunction with its commercial activities, the company is engaged in improving regulations in the various countries it trades in, in order to optimise the position that ventilation holds in the construction industry. Aereco, with its head office and factory at Marne-la-Vallée, in France, is represented worldwide through numerous subsidiaries and distributors.

**Marc Jardinier**  
CEO of Aereco S.A.

# CONTENTS

Aereco, air on demand	2
Why demand controlled ventilation?	5
Direct advantages of demand controlled ventilation (DCV)	6
Numerous additional benefits	7
Intelligent sensors	8
Which ventilation technique to choose?	10
Aereco, a solution for every ventilation technique	11
Mechanical exhaust ventilation with demand controlled airflows	12
Mechanical exhaust ventilation with heat recovery (MVHR)	16
Hybrid ventilation with demand controlled airflows	20
Natural ventilation with demand controlled airflows	24
Mechanical ventilation with heat recovery: DX System	28
Demand controlled ventilation for non-residential buildings: VMX System	32
<b>Products</b>	<b>37</b>
<b>Air inlets</b>	<b>38</b>
EMM <sup>2</sup> Humidity sensitive air inlet for windows	38
EHA <sup>2</sup> Acoustic humidity sensitive air inlet for windows	40
EAH <sup>2</sup> Humidity sensitive air inlet for rolling shutter casings	42
EHT Wall humidity sensitive air inlet	44
External canopies	46
E-TFR Window telescopic sleeve	48
<b>Exhaust units</b>	<b>50</b>
G2H Multi-controlled exhaust unit for natural and hybrid ventilation	50
GHN Humidity sensitive exhaust unit for natural and hybrid ventilation	52
BXC Demand controlled exhaust unit for MEV	54
GBP Humidity sensitive exhaust unit for natural and hybrid ventilation	56
TDA Exhaust unit with presence detection for MEV	58
<b>Exhaust fans</b>	<b>60</b>
V2A Acoustic whole-house fan – 2 rooms	60
V4A Acoustic whole-house fan – 4 rooms	62
V5S Whole-house fan – 5/6 rooms	64
VAM Acoustic whole-house fan – 6 rooms	66
VTZ Collective fans for outdoor installation	68
VCZ Collective fans for attic or outdoor installation	70
AWN DV Exhaust fan with heat recovery module outdoor terrace installation	74
AWN RV Exhaust fan with heat recovery module under roof or outdoor installation	76
VBP Assistance fan for hybrid ventilation	80
VBP+ Assistance fan for hybrid ventilation	82
<b>DX system</b>	<b>86</b>
DXR Heat recovery unit for ceiling installation	86
DXA Heat recovery unit for wall installation	88
DX Hub Active air supply distribution box	90
<b>Sensors</b>	<b>94</b>
S-SERIE Indoor air quality sensors with digital and analog outputs	94
<b>Accessories</b>	<b>97</b>
<b>Appendix</b>	<b>103</b>
Monitoring the performance of the demand controlled MEV system	105
Aereco demand controlled MEV: a relevant, low-cost alternative to constant heat recovery ventilation	107
Ventilation systems and product breakdown	108
Which parameters to control the exhaust airflows?	109
Ecodesign Directive (ErP): information requirements for fans and ventilation units (RVU)	110
Certifications & regulations	111
References	112
Aereco group	114

# WHY DEMAND CONTROLLED VENTILATION?

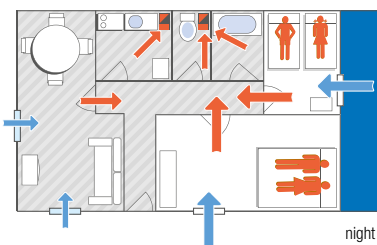
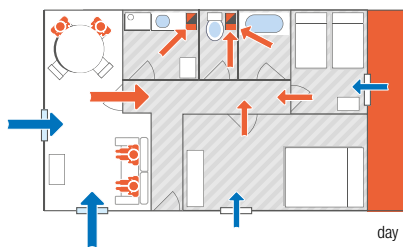

## Balance indoor air quality and energy savings with demand controlled ventilation

It is commonly accepted that most water distribution facilities work on demand, and not permanently. Thus why should it be different for ventilation, with each cubic meter of fresh air to warm during all the heating season having a significant economic and environmental cost?

The concept of demand controlled ventilation rests on the principle of providing occupants with the right amount of fresh air, when they need it, where this is useful. With intelligent airflow management, energy savings are made on every occasion that the need for ventilation is low, which can represent more than half the time. Conversely, an activity which emits indoor air pollution such as preparation in a kitchen, a shower, or even the release of odorous metabolic compounds, generates a need for a greater ventilation to remove the pollution quickly, which can be achieved through demand controlled ventilation.

At every moment, demand controlled ventilation offers an optimization of heating consumption and indoor air quality, on a fully automated basis. Every Aereco ventilation system is design on this concept of demand controlled ventilation, which beyond being particularly effective for the comfort of the occupants offers many other benefits as presented later.

1. Humidity sensitive air inlets open in direct proportion to the occupancy of the rooms.

## How does it works?

### Intelligent airflow distribution inside the dwelling (1)

The Aereco demand controlled ventilation system optimises air distribution within the dwelling: thanks to the humidity sensitive air inlets, it directs the most air to the rooms that need it most. In this way, the system limits heat losses in unoccupied rooms and provides good ventilation where it is needed. The same principle is used at the exhaust through demand controlled exhaust units.

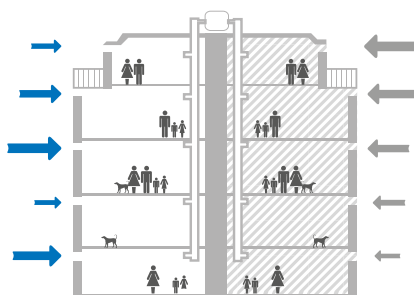

### An airflow always automatically adapted to the pollution and to the occupancy (2)

2. Aereco demand controlled ventilation | constant airflow ventilation

To meet the variable need for ventilation, Aereco ventilation systems provide an airflow automatically determined by the level of pollution or occupancy inside each dwelling, contrary to the constant airflow ventilation systems. Thus the residences with higher occupancy or pollution benefit from more ventilation to offer a good indoor air quality; the residences where occupancy is less have a lower airflow, saving energy both on heating and on fan electrical consumption.

## DIRECT ADVANTAGES OF DEMAND CONTROLLED VENTILATION (DCV)

### Better air renewal for greater comfort

By providing the best ventilation for the places that need it most, Aereco's demand controlled ventilation systems largely contribute to improving air quality in dwellings. When a main room is occupied, its relative humidity increases; the air inlets then open more to increase airflow and better evacuate stale air. Activity in wet rooms (kitchen, bathroom, toilets, etc.) is accompanied by water vapour emissions; the opening of the exhaust units increases with the relative humidity, increasing the airflow and so evacuating polluted air more rapidly.

### Protection against moisture

The higher relative humidity generated by breathing and human activity in the kitchen or shower, for example, can lead to destructive condensation, in which moulds can grow. When the relative humidity increases dangerously, humidity sensitive exhaust units open quickly to evacuate excess moisture and eliminate the risk of condensation.

### Reduced and controlled heating consumption

Ventilation is often held responsible for a large share of the thermal losses in a dwelling, sometimes as much as 50%. While this is true of the majority of traditional ventilation processes, Aereco systems preserve heat in less occupied rooms and dwellings by automatically reducing the airflow.



## NUMEROUS ADDITIONAL BENEFITS

In addition to combining indoor air quality and energy savings optimisation, **demand controlled ventilation demonstrates many indirect benefits resulting from the reduction of average airflow:**



### Reduced average power consumption of the demand controlled exhaust fan

By reducing the average airflow rate, demand controlled ventilation systems allow the exhaust fan to work well below the maximum airflow, thus at a very low power. This aspect clearly promotes unbalanced demand controlled ventilation systems such as those from Aereco, when compared with the standard heat recovery ventilation systems that typically have two motors operating at a higher speed (with higher average airflow), and are then particularly penalized in terms of environmental impact and consumption of electrical energy (primary notably).



### Less clogging of filters, air ducts and terminals

The inherently reduced airflow of demand controlled ventilation leads to the reduction of the total amount of particles that can clog the components of the system. Thus, maintenance of air ductwork and filters (where these have been used), can be reduced with the power consumption of the demand controlled exhaust fan (when presence of filters).

### Increased lifetime of fans

By reducing average airflow over the year, demand controlled ventilation permits a reduction of the demands placed on the exhaust fan, and thereby increases its longevity. This result is the consequence of the fact that the fan longevity depends in particular upon the power at which it works, the power being directly linked with the average airflow.



### Greater availability of pressure and airflow for exhaust grilles

In a collective air ductwork system, the airflow modulation permits the avoidance of overloading the air ducts with unnecessary airflow rates, as it would be the case with a constant airflow ventilation system. Thus, the rooms or dwellings with a low airflow requirement release the air duct for the rooms or dwellings with a higher need for ventilation. These last can then benefit from all the pressure and airflow potential of the ductwork.

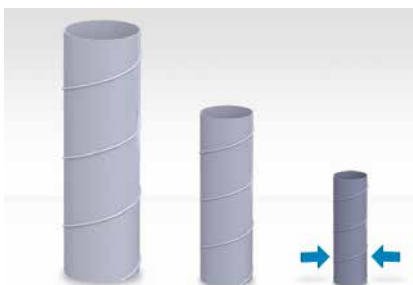







### Reduced size of air ductwork to gain on valuable floor space

In demand controlled ventilation, airflow modulation permits a reduction in the size of the ventilation ductwork as not all of the connected exhaust vents work at the maximum level simultaneously. The air ductwork can therefore be sized for a total airflow lower than the sum of the maximum airflows, unlike that of a constant airflow ventilation system where the size of ducting corresponds to the strict sum of airflow. This use of smaller air ducts, can thereby allow a reduction in the total floor space required for ducting. The time dispersion of the ventilation needs has been verified during numerous in-situ experiments.

# INTELLIGENT SENSORS

Aereco ventilation components include smart sensors that manage the airflows according to the needs and to the inner pollution. Different sensors are proposed in the products, depending on the room type and of the pollution.

## Aereco system's major activation modes

-  Humidity sensitive airflow, created by Aereco in 1984
-  Airflow activated by presence detection
-  Airflow activated by a CO<sub>2</sub> sensor
-  Airflow activated by a VOC sensor
-  Airflow activated by a remote control
-  Manually activated airflow



## Humidity sensitive airflow

**Principle: the airflow is controlled by the local relative humidity.** The detector and actuator of the humidity sensitive products, the sensor, makes use the tendency of polyamide strips to become longer when the relative humidity of the air increases and shorter when it decreases. This principle is used to activate one or more shutters, thereby adjusting the passage of the air according to the ambient relative humidity. The higher the humidity in the room, the wider the shutters open. The sensor is isolated from the incoming airflow; it measures only the interior moisture content. Moreover, thanks to a thermal correction, the opening of the shutters is unaffected by the external climatic conditions. Aereco's humidity sensitive technology is applied to air inlets, grilles, and exhaust units located in the rooms where the humidity reflects the level of indoor pollution (lounge, bedrooms, bathrooms).



## Airflow activated by a presence detector

**Principle: automatically increase the airflow when a presence is detected in the room.** The presence of somebody in the room automatically activates the detector, which then opens the shutters of the exhaust unit for maximum airflow. This process is used when moisture is not sufficient to reveal of a high pollution level. This technology makes it possible to save heating energy during the period of non-detection. The presence detection module comprises a pyroelectric sensor that detects infrared radiation focused by a Fresnel lens, with a 4-meter range and a 100° angle of detection. The presence detection technology is used on exhaust units and mechanical ventilation terminals in rooms where the relative humidity cannot be used as an indicator of the pollution level (toilets, offices, etc.).



## Manually activated airflow

**Principle: let the occupant increase the exhaust airflow at times of intensive pollution.** Where the relative humidity cannot be used as an indicator of high pollution (kitchen, toilets, etc. in use) the occupant can manually activate the maximum airflow at the exhaust unit to quickly evacuate stale air, unpleasant odours, and excess moisture. This boost can be activated by a push button ('on-off switch'), by pulling a cord, or through a remote control. This function can also supplement a humidity sensitive function on an exhaust unit.



## Airflow activated by a CO<sub>2</sub> or VOC sensor

**Principle: control the airflow automatically according to the level of CO<sub>2</sub> or VOC.** Both sensors operate the same way: the opening threshold is selected at the time of installation. When the level of CO<sub>2</sub> (or of VOC, depending on the version of the product) is below the opening threshold, the airflow is at the baseline rate (minimum). When the level of the pollutant rises above this threshold, the exhaust grille opens to the maximum airflow for as long as the level of pollution exceeds the preset threshold.

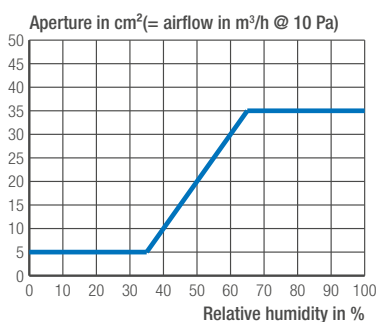

**Aeraulic characteristics of an Aereco humidity sensitive air inlet.**



Humidity sensitive mechanism (in blue) of an Aereco air inlet



Presence sensor of an exhaust unit

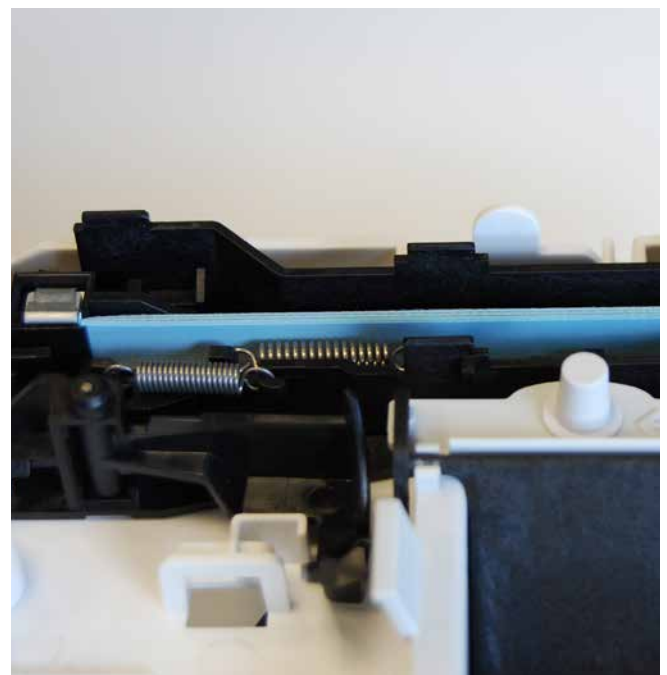

Humidity sensor of an exhaust unit

# WHICH VENTILATION TECHNIQUE TO CHOOSE?

The table below offers an overview of different ventilation techniques and their respective abilities in regard with several features and parameters, helping you choosing the appropriate system. The notation takes into account the demand controlled ventilation associated with these techniques, contributing to increase the note for most of the parameters involved in comparison with constant airflow systems.

Ventilation technique / system	Natural ventilation (PSV)	Hybrid ventilation	Mechanical exhaust ventilation (MEV)	MEV with Heat Recovery (MEVHR)	Mechanical Ventilation with Heat Recovery (MVHR)
<b>Indoor air quality</b>					
Ventilation flow control	++	+++	++++	++++	+++++
Boost airflow	-	++	+++	+++	++++
<b>Energy performance</b>					
Savings on heat losses	++	+++	++++	+++++	+++++
Low consumption of the fan	++++	+++	++	+	-
<b>Acoustics</b>					
Quiet working	++++	++++	++	++	+
Insulation from outdoor noise	++	++	++	++	++++
<b>Installation</b>					
Low cost installation	++++	++	++	-	--
<b>Maintenance</b>					
Easy maintenance	++++	+++	++	-	--
Low criticality in case of fan failure	++++	++++	-	--	-
<b>Aesthetic integration</b>					
Discretion and compactness of terminals	-	-	++	++	++
<b>Investment</b>					
Low cost investment	+++++	++	++++	++	-
<b>Markets</b>					
Individual houses	+	-	++++	-	++++
Collective dwellings	++++	++++	++++	++++	+
<b>Main benefits</b>					
	<ul style="list-style-type: none"> <li>No fan consumption</li> <li>No maintenance</li> <li>No air noise at the terminals</li> <li>Low cost solution</li> <li>No risk of failure (no electrical product)</li> </ul>	<ul style="list-style-type: none"> <li>Low fan consumption</li> <li>Controlled airflow throughout the year</li> <li>Low maintenance</li> <li>No air noise at the terminals level</li> <li>Low criticality in case of exhaust fan failure (than natural ventilation)</li> <li>Affordable solution</li> </ul>	<ul style="list-style-type: none"> <li>Airflows controlled and guaranteed all year long</li> <li>Possibility of having boost airflow</li> <li>Good acoustic insulation between the dwellings through the ducts</li> <li>Compact ventilation terminals</li> <li>Affordable solution</li> </ul>	<ul style="list-style-type: none"> <li>Airflows controlled and guaranteed all year long</li> <li>Possibility of having boost airflow</li> <li>Additional energy savings through the heat exchanger</li> <li>Good acoustic insulation between the dwellings through the ducts</li> <li>Compact ventilation terminals</li> </ul>	<ul style="list-style-type: none"> <li>Airflows controlled and guaranteed all year long</li> <li>Additional energy savings through the heat exchanger</li> <li>Supply airflow filtered and very precisely managed</li> <li>Possibility of having boost airflow</li> <li>Good acoustic insulation between the dwellings through the ducts and from the outdoor</li> <li>Compact ventilation terminals</li> </ul>

**AERECO, A SOLUTION  
FOR EVERY VENTILATION TECHNIQUE**



## MECHANICAL EXHAUST VENTILATION WITH DEMAND CONTROLLED AIRFLOWS



## High performance through affordable ventilation solution

Aereco's Mechanical Exhaust Ventilation system with room-by-room demand control of airflows is mainly used in Residential buildings, but it can also be installed on office or school buildings, notably. This system conciliates energy performance and indoor air quality through a very affordable solution, easy to implement in the new built as well as in refurbishment.

With the promise to deliver the designed airflows, the MEV system is the Aereco's most popular solution, from social housing associations to private owners. By proposing a humidity controlled air supply in the dry rooms and a humidity or presence – notably – control of the air exhaust in the wet rooms, the MEV system offers a very smart management of airflows in all rooms.

This system can be used either in collective management (multi-family buildings) through a common centralised fan, or individually, with one fan per dwelling (multi-family buildings or detached house).

### Management of indoor air quality

The Aereco's MEV system has been designed to optimise the indoor air quality through its smart air inlets and exhaust units that automatically detect the need. For example, during the night, the humidity generated by the occupants in the bedrooms is detected by the air inlets to adapt and increase the airflow, providing good indoor air quality. During the day, the humidity generated by a shower is detected then exhausted by the unit, automatically activated at the highest airflow.

### Energy savings on heat losses as on electrical consumption

The smart management of airflows enables to adapt automatically the ventilation to the needs in all rooms, at any time. When the dwelling is low or not occupied, the airflows are automatically reduced in all rooms, preserving the heat in winter and reducing the energy consumption of the fan. According to the conditions, the energy savings on the heating related to ventilation can be estimated between 25% and 50%, and so the electrical consumption of the fan.

### An amazing cost-performance ratio

One of the reason why the Aereco's MEV system has become so popular is its amazing cost-performance ratio. Much more affordable (between 3 to 6 times) than top-of-the-range systems such as, example given, mechanical ventilation with heat recovery (MVHR), this system is a perfect solution in residential applications for those who are looking for efficient and easy to implement solutions. A study realised by the Fraunhofer Institute IBP (Germany) has demonstrated that the efficiency of the Aereco's MEV system is actually close to the one of MVHR, both on the indoor air quality aspect and on the energy side.

### Ideal to retrofit and improve the performance of an existing standard MEV installation

This system uses the same ductwork, connexion holes and inlet slots as the ones of standard MEV systems. This means that the replacement of a standard MEV system by the Aereco's MEV system is very simple. The inlets and exhaust units can directly be changed. No wiring is needed at all in general: the humidity sensor of the air inlets and exhaust units is mechanical (no electricity), and the other activation modes for the exhaust units can be either mechanical or on battery.

The exhaust fan has just to be changed for a constant pressure one, as proposed in the Aereco range. There is no need to balance the ductwork nor to set the components: the system automatically adapts the airflows.

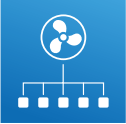

## CONTROLLED MECHANICAL EXHAUST VENTILATION (MEV)

### Collective treatment for apartments

In collective mechanical exhaust ventilation, the air in a building is renewed by a fan, installed on the roof or other convenient outside location. In demand controlled ventilation, the air extracted through the exhaust units (2) of the wet rooms determines the air renewal of the entire dwelling. The humidity sensitive air inlets (1) then distribute the new air according to the needs of each main room. The demand controlled exhaust units distribute the airflow generated by the fan (3) according to the needs of each wet room, in each dwelling. Thus rooms, or dwellings, with high new air requirements induce more airflow than empty ones.

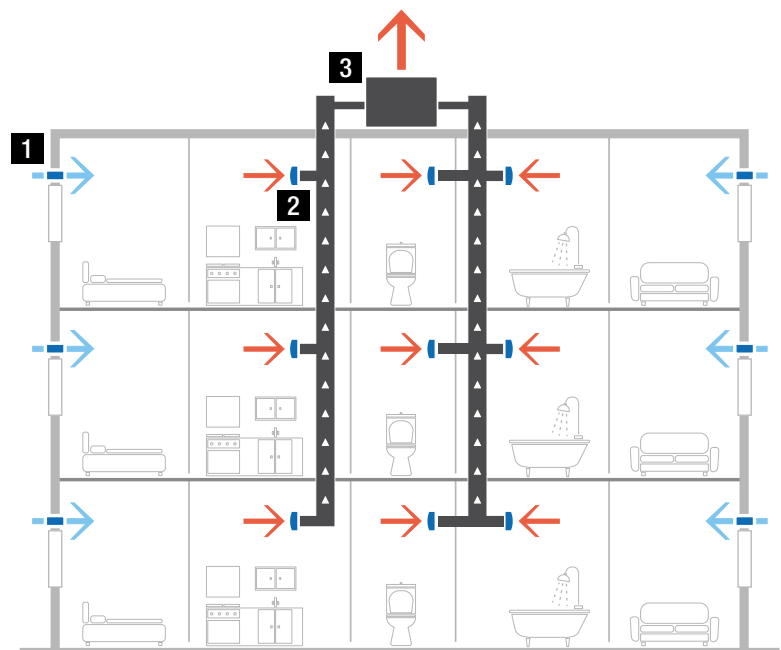

1



2



3



**CONTROLLED MECHANICAL EXHAUST VENTILATION (MEV)**  
 Individual treatment for apartments or houses

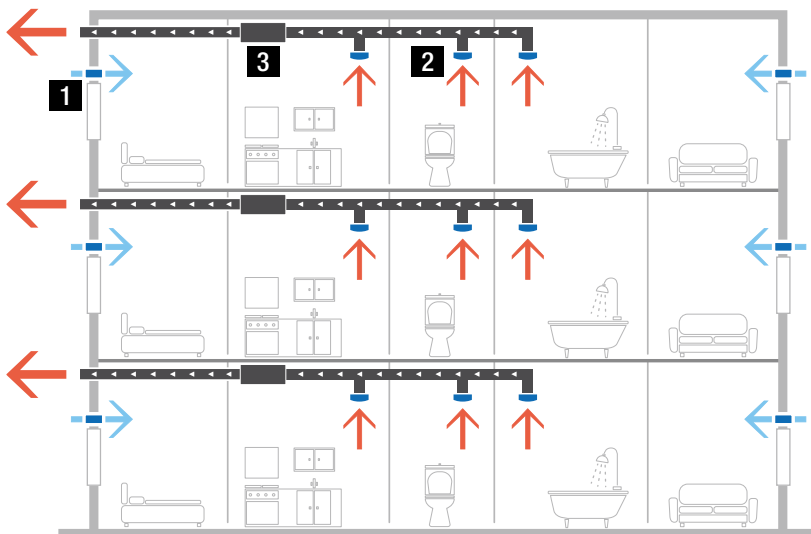

In this case, the fan is placed inside the dwelling. This treatment is applicable to individual houses as well as apartments. Placing the fan inside the dwelling has the advantage of making it directly accessible, a welcome advantage when it comes to maintenance.

As with collective MEV, the air in the dwelling is renewed by a fan (3). In demand controlled ventilation, the air extracted through the exhaust units (2) of the wet rooms determines the renewal of air in the entire dwelling. Humidity sensitive air inlets (1) then distribute the new air according to the needs of each main room. The demand controlled exhaust units distribute the airflow generated by the fan according to the needs of each wet room. Thus rooms with high new air requirements induce more airflow than empty rooms.





## MECHANICAL EXHAUST VENTILATION WITH HEAT RECOVERY (MEVHR)



## Demand controlled ventilation, even more energy efficient

The MEV system with heat recovery enhances again the energy performance of the Aereco's Mechanical Exhaust Ventilation: by adapting the airflows according to the needs in the dwelling, the Aereco demand controlled system already reduces consequently the heat demand. Through recovering the heat air energy at the level of the exhaust fan, this system drastically reduces the energy load for the air renewal. The AWN fan with heat recovery is connected to a heat pump that can be used for water heating or air heating. The AWN range of fans offers two types of calorigen fluid: water + glycol or refrigerant.

### Decreasing the energy load of the heating system

Through this system, an important part of the energy induced by the ventilation can be recovered and then be reused to decrease the energy demand of the energy generating system. In the presence of a heat pump for heat generation, this energy can be directly integrated into the heat source circuit (brine or air). In the case of other heat generators, this energy quantity can be brought from the exhaust air to a temperature level (max. 50°C) by means of an autonomous heat pump.

Thus, for example, the preheating of the hot water is possible or is provided in a buffer store for the heating and / or hot water. In the case of combined use of the ventilation and heat pump technology, a heat exchanger is installed in front of the exhaust fan. The remaining usable energy is extracted from the exhaust air. Intelligent control optimizes the supply and demand of energy from exhaust air and outside air.

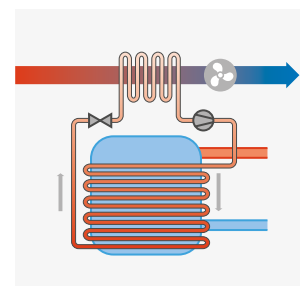
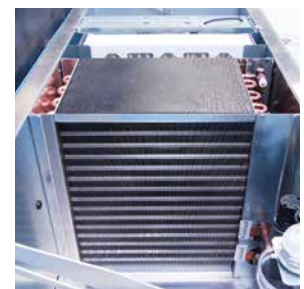

From top to bottom: heat exchanger on the exhaust air (included in the AWN fan), heat pump and hot water storage.



## MECHANICAL EXHAUST VENTILATION WITH DEMAND CONTROLLED AIRFLOWS AND HEAT RECOVERY

### Collective treatment for apartments

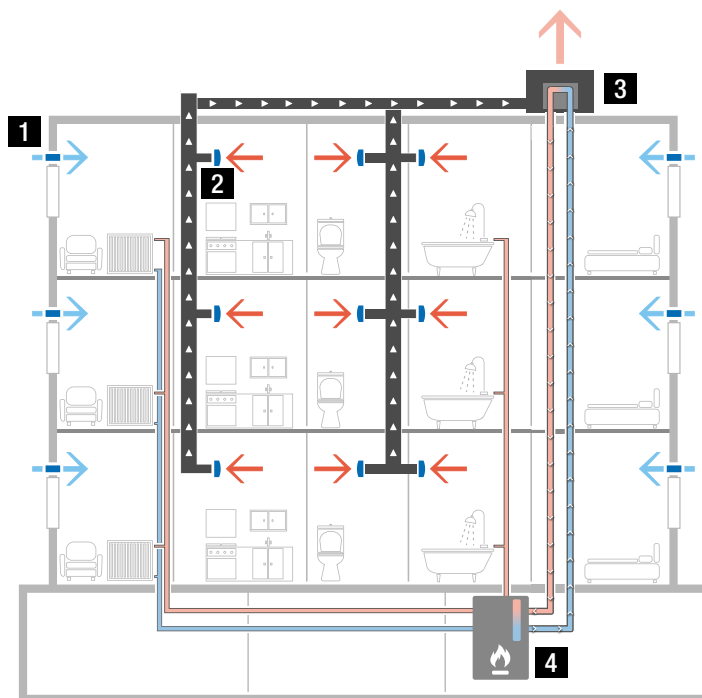

The air in a building is renewed by the fan installed in the roof. The air extracted through the exhaust units (2) of the wet rooms determines the air renewal of the entire dwelling. The humidity sensitive air inlets (1) distribute the new air according to the needs of each main room. The demand controlled exhaust units distribute the airflow generated by the fan (3) according to the needs of each wet room, in each dwelling. Thus rooms, or dwellings, with high new air requirements induce more airflow than empty ones.

With the AWN, the fan (3) includes a heat exchanger that is connected to a heat pump (4) that assists the distribution of domestic hot water in the dwellings, through the recovery of a part of the heat that is contained in the exhausted air.







## **HYBRID VENTILATION WITH DEMAND CONTROLLED AIRFLOWS**



## Smart upgrade of the passive stack ventilation

The Aereco's Hybrid Ventilation system is mainly used in residential buildings, with room-by-room demand control of airflows. This system conciliates energy performance and indoor air quality through an affordable solution, easy to implement in refurbishment notably. The Aereco's Hybrid Ventilation system is a perfect solution for upgrading buildings formerly working in passive stack ventilation, through the installation of low pressure assistance fans supplying additional pressure to complement the stack effect.

By proposing a humidity controlled air supply in the dry rooms and a humidity or presence -notably- control of the air exhaust in the wet rooms, this system offers a very smart management of airflows in all rooms.

The Hybrid Ventilation system is dedicated to offices, schools or multi-family buildings. With its very low need for maintenance, it is particularly suitable for social housing associations.

### Management of indoor air quality

The Aereco's Hybrid Ventilation system has been designed to optimise indoor air quality through its smart air inlets and exhaust units that automatically detect the need. For example, during the night, the humidity generated by the occupants in the bedrooms is detected by the air inlets to adapt and increase the airflow, ensuring good indoor quality. During the day, the humidity generated by a shower is detected then exhausted by the unit, automatically activated at the highest airflow.

### Energy savings on heat losses as on electrical consumption

The smart management of airflows proposed by this system enables to adapt automatically the ventilation to a needs in all rooms, at any time. This means that, when the dwelling has low or no occupancy, airflows are automatically reduced in all rooms, preserving the heat in cold season and reducing the energy consumption of the fan, which is already particularly low (very low pressure working).

### No need to reinforce the airtightness of the existing passive stack ventilation ductwork

By keeping the low pressure of the passive stack ventilation (around 5 to 15 Pa at the exhaust grilles), the Aereco's Hybrid Ventilation system can be directly installed on existing PSV ductwork, with no need to measure nor reinforce airtightness.

### Ideal to retrofit and improve the performance of an existing standard PSV installation

This system uses the same ductwork, connexion holes and inlet slots as the ones of a standard PSV system. This means that the upgrade of a standard PSV system by the Aereco's Hybrid Ventilation system is very simple. The inlets and exhaust units can directly be replaced. No wiring is needed at all in general: the humidity sensor of the air inlets and exhaust units is mechanical (no electricity), and the other activation modes for the exhaust units can be either mechanical or on battery.

The assistance fans are easily installed at the top of the vertical ducts through adaptation parts. No need to balance the ductwork nor to set the components: the system automatically adapts the airflows.

### Low criticality

The assistance fans used in this system have a special patented design to work on both mechanical or passive modes, depending on the thermal or wind conditions. This means that, in case the fan is stopped, it does not create pressure drop, then allows the ventilation to operate in natural mode.



## HYBRID VENTILATION

### Collective treatment for apartments

A cross between passive stack ventilation and mechanical exhaust ventilation, hybrid ventilation that uses the components and dimensioning of the passive stack ventilation ducts coupled to non-permanent low-pressure mechanical assistance fan (3). The mechanical assistance is used as a complement when the natural forces are not sufficient to ensure the required airflow. It can be managed automatically by a temperature sensor, a timer or even a wind gauge.

The fresh air is admitted by humidity sensitive air inlets (1) in the main rooms (bedrooms and living rooms); the stale air is evacuated through the wet rooms (toilets, bathroom, kitchen) through demand controlled exhaust units (2). These components control the airflows according to the needs of each room.

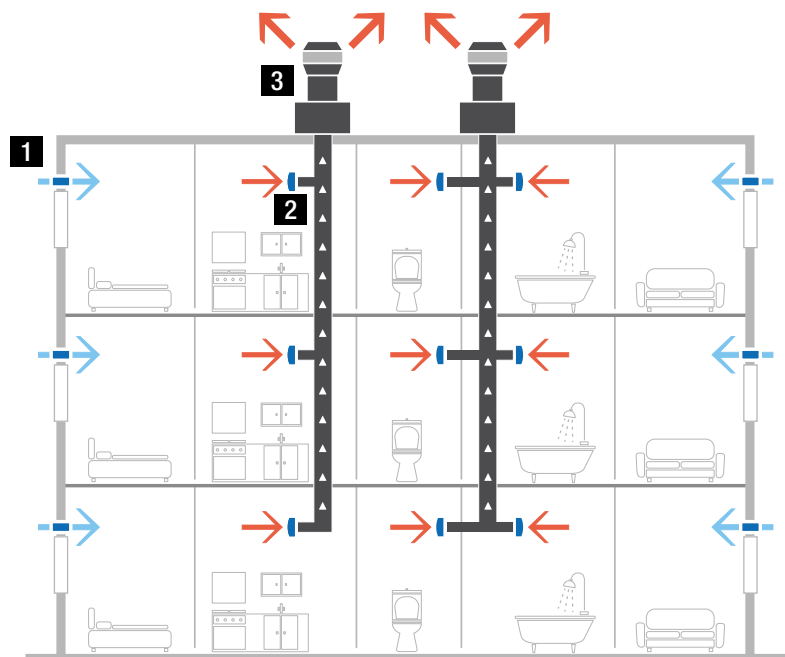





## NATURAL VENTILATION WITH DEMAND CONTROLLED AIRFLOWS



## Smart management of thermal draught, better use of pressure

The Aereco's Natural or Passive Stack Ventilation (PSV) system used mainly in residential buildings, with room-by-room demand control of airflows. The Aereco's Natural Ventilation system is a perfect solution for upgrading buildings formerly working in standard passive stack ventilation, by just replacing the inlets and exhaust grilles by smart components.

By proposing a humidity controlled air supply (in the dry rooms) and air exhaust (in the wet rooms), this system offers a very smart management of airflows in all rooms. The humidity controlled exhaust grilles also manage the stack effect, balancing the pressures and airflows along the duct column.

This Aereco's system is especially dedicated to multi-family buildings. With its very low need for maintenance, it is particularly suitable for social housing associations.

## Management of indoor air quality

The Aereco's PSV system has been designed to optimise indoor air quality through its smart air inlets and exhaust units that automatically detect humidity. For example, during the night, the humidity generated by the occupants in the bedrooms is detected by the air inlets to adapt and increase the airflow, ensuring good indoor quality. During the day, the humidity generated by a shower is detected then exhausted by the unit, automatically activated at the highest airflow.

## Energy savings on heat losses

The smart management of airflows proposed by the Aereco's PSV system enables to adapt automatically the ventilation to the needs in all rooms, at any time. This means that, when the dwelling has low or no occupancy, airflows are automatically reduced in all rooms, preserving the heat in cold season and reducing the energy consumption of the fan.

## Ideal to retrofit and improve the performance of an existing standard PSV installation

The Aereco's PSV system is an easy upgrade of a standard PSV system, through the simple replacement of the inlets and exhaust grilles. No wiring, no electricity: the humidity sensor of the air inlets and exhaust units is fully mechanical. No need to balance the ductwork nor to set the components: the system automatically adapts the airflows.

## Very low maintenance

Without fan, this system requires very low maintenance, through a simple yearly dusting of the inlets and exhaust grilles.



## NATURAL VENTILATION

Individual treatment for apartments or houses

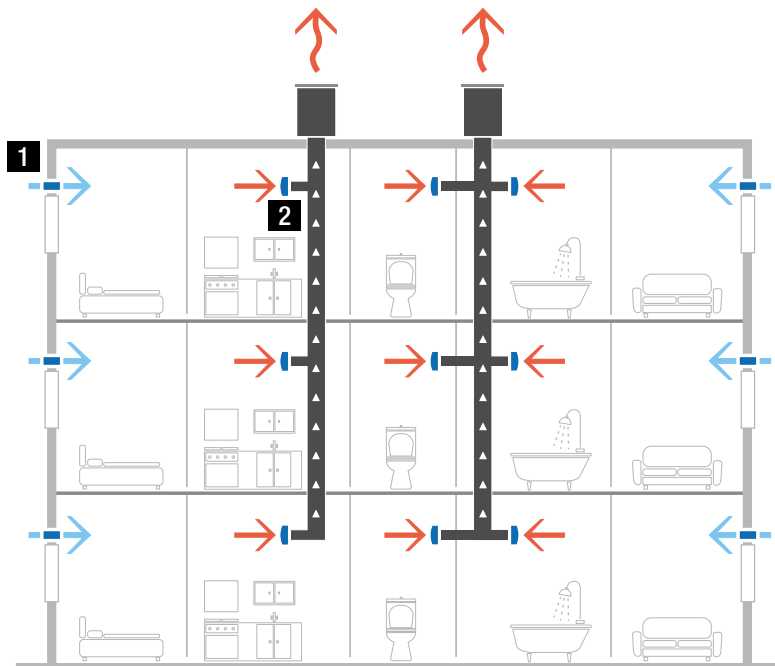

In both individual housing and collective housing, natural ventilation exploits the natural forces (wind and stack effect) to renew the air within the dwellings. These forces create a pressure in the air duct that starts air circulation from the inside of the dwelling towards the air duct and then outside.

The air is exhausted through the wet rooms via exhaust units (2), and this induces an admission of fresh air through air inlets (1) situated in main rooms. Depending upon natural forces (wind and stack effect), the natural ventilation may be random: it is therefore necessary to control it.

The humidity sensitive system, while measuring the humidity rate to drive the necessary airflow, gives an appropriated answer to the variability of the natural forces as it allows to compensate automatically the variation of stack effect, especially in winter.

The pressures available in natural ventilation are from 5 to 15 Pa at the units, depending on building height and climatic conditions.







## MECHANICAL VENTILATION WITH HEAT RECOVERY DX SYSTEM



## DX System – as flexible as you would need

Through the DX System, a completely new range of heat recovery ventilation system has been designed by Aereco to offer you the maximal flexibility in your choice for the adequate ventilation solution.

The heat recovery ventilation system is the ideal solution for optimum air quality throughout the year while minimizing the energy consumed. This system supply healthy and preheated outdoor air into living areas. Indeed, before being supplied into the housing, the outside air passes through high-performance filters to remove all the particles present on the outside. The air is subsequently extracted into the humid rooms. A heat exchanger, incorporated in the ventilation unit, allows the transfer of calories between fresh air and stale air without impurity transfer. By eliminating the air inlets above the windows, the heat recovery system also guarantees optimum acoustic insulation between the exterior and the interior of the housing.

While most ventilation systems on the market offer constant or globally controlled airflows, DX System stands out as one of the first residential heat recovery ventilation to automatically adjust ventilation according to the specific needs of homes, locally or globally. DX System is dedicated to residential applications and can be either installed in false ceiling, thanks to a small thickness, or in kitchen cupboard, due to optimized dimensions.

By combining the benefits of full demand controlled airflows and heat recovery, which are the pillars of the DynamiX® technology, the DX System, in Excellence version, delivers outstanding energy performance. Modulation enables a significant reduction in average airflows while providing excellent air quality, with heat losses produced by ventilation lowered by half on average in comparison with a constant airflow ventilation. The heat exchanger operates with an efficiency of about 87% recovery (DXR: 82%; DXA: 93%). Combined, these features achieve about 92% (DXR) energy savings when compared with a mechanical exhaust ventilation system at constant airflow, with the same indoor air quality. (1) (2)

### A comfortable climate

Heat recovery ventilation DX System continually supplies pollen-free and dust-free fresh air to living areas, ensuring a comfortable feel-good climate. The supply air is preheated by the exhaust air in the very efficient heat exchanger and by the optional preheater.

### Best energy efficiency (1,2 and 3)

Whether fully room-by-room demand controlled (Excellence version) or partially room-by-room controlled at the supply and room-by-room controlled at the exhaust (Premium version), the DX System optimally uses the exhaust heat to preheat the fresh air and thus offers an energy-efficient solution, whatever the version. Moreover, the demand controlled management enables to decrease significantly the electrical consumption of the system. The best energy-efficiency class A+ is achieved by all the versions of the DX System.

### Even in summer, DX ventilation systems are the best choice

As soon as the temperatures rise, the fresh air flows pass through the heat recovery and is directed into the living areas without need for preheating. In cooler summer nights, the fresh air can be used to cool down the heated rooms, by bypassing the heat exchanger.

### Easy to maintain (4)

A colour LCD touch screen allows the occupant to view system parameters, to diagnose operation, to control setups such as automatic bypass temperature, to boost ventilation or to action a free cooling on demand. It also notifies the occupant when the filters need to be replaced.

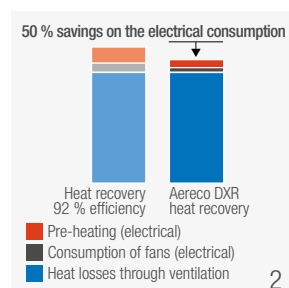
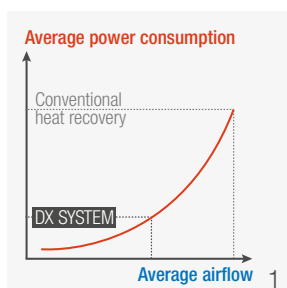



## MECHANICAL VENTILATION WITH HEAT RECOVERY

### Individual treatment for houses and apartments

#### DX SYSTEM

The DX System is comprised of a heat recovery unit (DXA Unit or DXR Unit **1**) connected to exhaust and supply ductworks. The counter-flow heat exchanger, integrated into the main unit, ensures the recovery and transfer of most of the energy from the exhaust air to the supply air, thus limiting the energy required to heat the fresh air.

Airflows are automatically controlled according to the needs of each dwelling's room (room by room DCV): Outdoor filtered air is supplied **3** in the bedrooms and in the living room. Stale air is extracted **6** from the kitchen, bathroom and WC.

On the supply side, depending on the DX System version installed, one or many sensors **5** can adjust the airflow to all main rooms based on the CO<sub>2</sub> level or based on the presence detection.

On the exhaust side, the BXC units adjust automatically the airflow, according to parameters read by various sensors: humidity (used in the kitchen, in the bathroom and in WC), presence (can be used in WC). Versions with switch, presence, remote, CO<sub>2</sub> or VOC sensors can also be used for exhaust units.



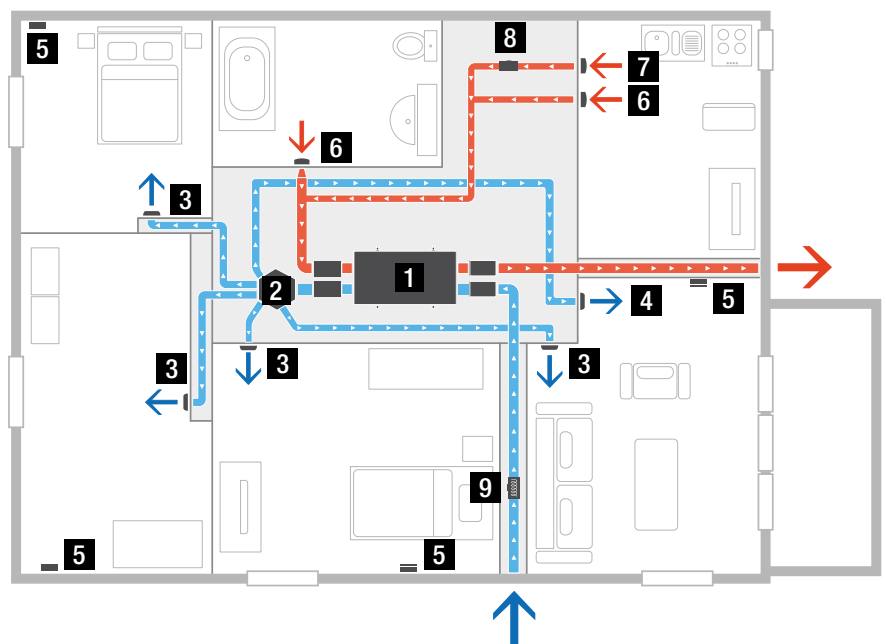







At all times, total supply airflows and total exhaust airflows are measured by the heat recovery unit. These airflows are balanced thanks to an exhaust controlled compensation valve **8**. This valve can be located in the bathroom or in the kitchen. In Excellence version only, an additional compensation valve, integrated in the DX Hub **2**, adjusts supply compensation airflow, supplying preheated **9** fresh air in the living room, in the kitchen or in a corridor. Compensation valves are linked to dedicated compensation exhaust unit **7** or dedicated compensation supply unit **4**. The use of an exhaust compensation valve is also a solution to increase considerably the airflows. This scenario is used in order to get a very efficient over-ventilation mode, also called free cooling mode.



To reach the required supply airflows in each main room (bedrooms or living room), dedicated dampers located in the DX Hub **2** modulate room by room supply airflows according to the information sent by each electronic sensors placed in the main rooms. For example, when the main rooms are occupied, the presence or CO<sub>2</sub> sensors that are located in these rooms send the information to the system to adapt the airflow according to the demand. To reach the required exhaust airflows in each technical room (kitchen, bathroom, WC, ...), dampers located in the exhaust units modulate room by room extract airflows according to the passive or active sensor placed within each exhaust unit.

Supply airflows and exhaust airflows are measured by the use of accurate pressure sensors placed in the heat recovery unit. This allows to calculate with a high accuracy supply and exhaust airflows, without influence of clogging filters or ductwork pressure drop. It ensures the highest efficiency for the system. So that, energy savings are at their maximum.

**DX System components:**

			Premium version	Excellence version
1	 <p><b>DXR</b>      <b>DXA</b></p>	<p><b>DX Unit</b> Heat recovery unit with balanced demand controlled airflows</p>	x1 (DXR or DXA)	x1 (DXR or DXA)
2	 <p><b>HUB 5</b>      <b>HUB 6</b></p>	<p><b>DX Hub</b> Distribution box for demand controlled supply airflows</p>	-	x1 (DX Hub 5 or 6)
3		<p><b>SDC 100</b> Supply unit</p>	x1 to x6	x1 to x6
4		<p><b>SDC 125</b> Supply unit for balance</p>	-	x1
5		<p><b>S-CO2</b> CO<sub>2</sub> sensor</p>	at least x1 (S-CO2 or S-PRE)	x1 to x5 (S-CO2 or S-PRE)
5		<p><b>S-PRE</b> Presence sensor</p>		
6		<p><b>BXC</b> Exhaust unit with integrated humidity, presence detection or other sensors</p>	x1 to x5	x1 to x5
7		<p><b>BXC b</b> Exhaust unit for balance</p>	x1	x1
8		<p><b>Motorized valves</b> Exhaust compensation valve</p>	x1	x1
9		<p><b>Preheater</b> Galvanised steel body with built-in resistance</p>	x1 (optional)	x1 (optional)
		<p><b>Touch screen</b> Display and control module for the user also used for maintenance</p>	x1	x1

Note: some other components may be used in the system such as condensation exhaust pump, acoustic silencers, etc.

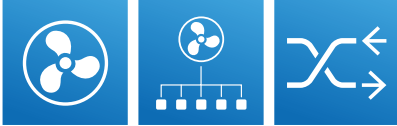

## DEMAND CONTROLLED VENTILATION FOR NON-RESIDENTIAL BUILDINGS VMX SYSTEM



## VMX, a demand controlled ventilation system for non-residential buildings

The VMX is a unique intelligent ventilation system for non-residential sector (restaurants, schools, offices, meeting rooms...). This system is easy to install both in the new built and the refurbishment buildings. The VMX automatically modulates the ventilation on the basis of information received from the detectors that measure CO<sub>2</sub> concentration, movements or detect presence. Thus, the air supply and exhaust flow rates are then matched to the true needs of the rooms functioned of the occupancy, reducing thermal losses and optimising electrical fan consumption. The VMX system is an affordable solution conciliating energy performance, indoor air quality and acoustic comfort that enhances rooms' occupant comfort.

### VMX, a smart ventilation system

Premises in non-residential buildings are characterized by highly variable and intermittent occupancy. For example, meeting rooms are generally used for a few hours and their occupancy is quite variable. Classrooms are completely empty during recreation periods, lunch breaks and vacation periods. The VMX, with its smart ventilation, is well suited for the tertiary sector and allows an optimal management of ventilation flow rates according to the occupancy of the room.

### Important energy savings

This system yields large energy savings by reducing airflow rates by 25 to 75%, on average, depending on the reference flow rates. Thanks to carbon dioxide or presence detectors placed at different locations in the room, the flow rates are managed strictly according to the needs. This avoids both over-ventilation, which would mean higher energy consumption, and under-ventilation, which could have negative impacts on the health, concentration, and comfort of the occupants.



from **25 %**  
to **75 %**  
energy savings

### Management of indoor air quality

With its different sensors, the VMX optimises indoor air quality by adapting automatically its ventilation to the needs of the room. If, for example, a room is highly occupied, the indoor air will be charged with CO<sub>2</sub>, humidity and odours emitted by the occupants which can result not only in discomfort and inconvenience but also in decrease of concentration. The VMX system, thanks to its sensors, will detect the occupancy rate and instantaneously activate the ventilation evacuating vicious air, bad odours and allowing new fresh air in the room.

### Three detection modes

VMX system offers the possibility to measure three types of information through three detection modes: the "Presence" mode, which adapts the ventilation according to the detected presence. The "Movement" mode, which induces a ventilation rate proportional to the number of movements measured. The "CO<sub>2</sub>" mode, which adjusts the airflow proportionally or binary (minimum / maximum) to the CO<sub>2</sub> rate.



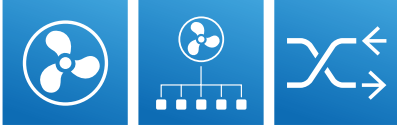

## VMX SYSTEM

### DEMAND CONTROLLED VENTILATION FOR NON RESIDENTIAL BUILDINGS

#### An open and functional system

The VMX system is an intelligent system which can be fully configured according to needs thanks to its several components (see next page). These elements can be adapted to most types of equipment commonly used for ventilation. They can also communicate with the majority of external systems (to provide information or to comply with instructions).

The VMX system can fit the existing ventilation network and has 2 ways of managing ventilation: “Unizone” or “Multizone” approach.



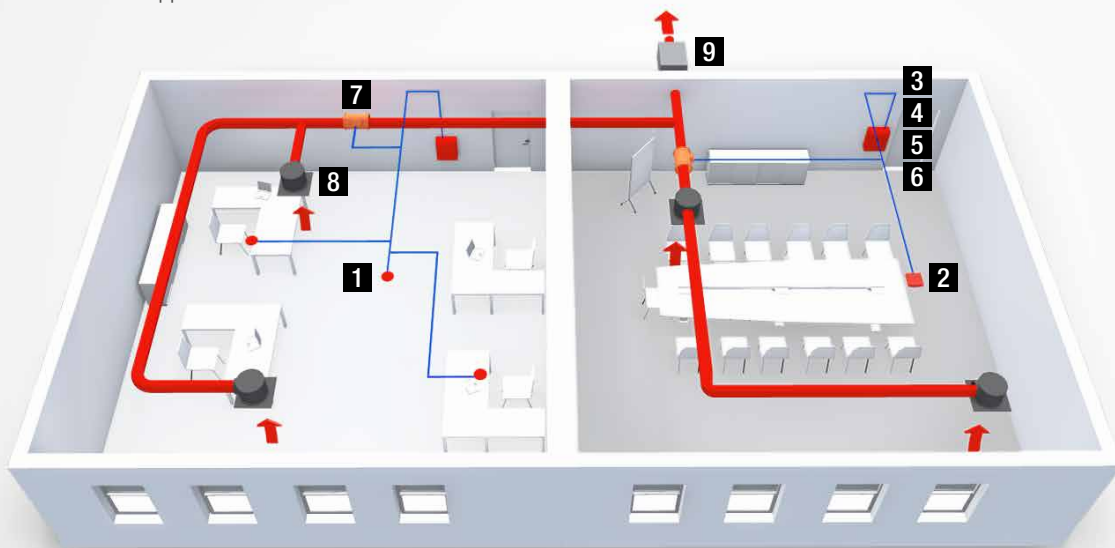





Example of a Multizone application



In a Unizone installation, the VMX system manages and controls the ventilation flow rates centrally, at the fan. This generally assumes that one fan is installed for each room. The detector in the room measures a parameter ( $\text{CO}_2$ , presence, movement, etc.) and sends a signal to the modules that control the fan to vary the airflow rate and thereby ensure optimal indoor air quality.

In a Multizone installation, the VMX system manages and controls the ventilation flow rates in a decentralized manner, on the motorized valves. Several valves and diffusers are connected to a single fan, which can serve one or several rooms. A single fan serves several air supply or exhaust valves and diffusers, located in a single room or in different rooms. There is generally one VMX system (one MAIN module) per room. The detector(s) placed in the room measure(s) various parameters (concentration of  $\text{CO}_2$ , presence, movement, etc.) and send signals to the modules that control the motorized valves (opening or closing of the flaps in a specified time) so as to adapt the airflow rates and thereby improve the indoor air quality.

### VMX System components:

1		<p><b>S-PRE*</b> Optical sensor for the VMX system. It measures presence or motion.</p>
2		<p><b>S-CO2*</b> Carbon dioxide sensor for the VMX system.</p>
3		<p><b>Main Module**</b> Main module for the VMX system.</p>
4		<p><b>CONTACT IN module*</b> Optional module for the VMX system. External instructions input.</p>
5		<p><b>IN/OUT 0-10V module*</b> Optional module for the VMX system. System status Output and/or external instructions Input.</p>
6		<p><b>RELAY OUT module*</b> Optional module for the VMX system. System status output.</p>
7		<p><b>Motorized valve (multizone only)</b> Exhaust compensation valve.</p>
8		<p><b>Diffuser(s)</b> Helical jet input or output airflow TROX XARTO diffuser. Airflow 324 to 990 m<sup>3</sup>/h. Exists in different designs, with a round or square facing. On special request only.</p>
9		<p><b>Fan</b> Aereco fan VCZ model.</p>

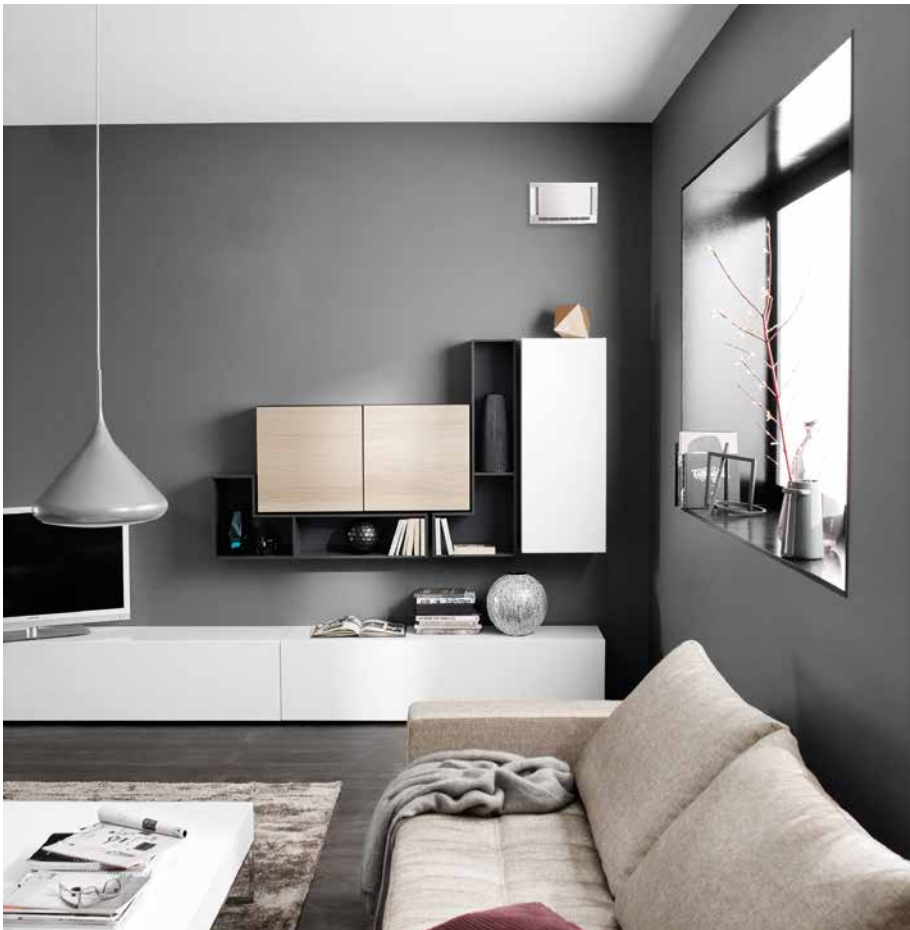

# PRODUCTS

## **General remark concerning the codes mentioned in the document**

These concern the standard product, i.e. without options or accessories. In general, they concern the white version, for the product delivered alone (not as part of a kit). Other codes are possible for other versions of the products. Please contact Aereco for the full list.

**Installation data are recommendations for optimal use of our products.**

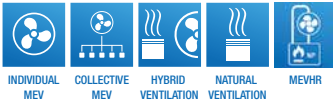

INDIVIDUAL MEV COLLECTIVE MEV HYBRID VENTILATION NATURAL VENTILATION MEVHR

NEW

## EMM<sup>2</sup>

Humidity sensitive air inlet for windows



**Slim design: only 31 mm thickness.**



**Humidity sensitive system: modulates the airflow according to the local relative humidity.**

**Directional airflow (horizontal) as accessory.**



**Manual closing and opening device in option.**

**Additional airflow sleeve available as an accessory.**



**Slim profile for easy installation on windows.**



**Easy to maintain: no adjustment, simple yearly dusting.**



### Slim design for perfect integration

With its slim design (only 31 mm thickness), the EMM<sup>2</sup> is optimised to discreetly integrate on all types of windows. Its humidity sensitive sensor modulates the airflow according to the ambient humidity level. The EMM<sup>2</sup> has specific accessories to increase the airflow or to adapt the air direction if necessary. The range is composed of 2 humidity sensitive versions and 4 different colors; its single-part front cover facilitates painting. Installed with a specific canopy, it provides an acoustic attenuation of 37 dB.

### Directional airflow (1)

The standard version offers an oblique airflow, which can be modified with the accessory O-EMM<sup>2</sup> to adjust the air jet horizontally in case of close proximity of windows reveals or ceilings. Therefore, the airjet is always optimal and the airflow guaranteed.

### Additional airflow sleeve (2)

The E-EMM<sup>2</sup> sleeve, available as an accessory, enables an increase in airflows for the different versions of the EMM<sup>2</sup> to satisfy regulatory requirements or to decrease the number of air inlets in some rooms.

### A manual closing and opening device (3)

This option, available on the 5-35 humidity sensitive version, allows you to choose between 3 modes: minimum, automatic (humidity sensitive) or maximum to adapt the airflow to the occupant's needs.





# EMM<sup>2</sup> Humidity sensitive air inlet for windows

## Air inlet

### Standard code

### Airflow characteristics

Humidity sensitive

Closing device

Airflow (min.-max.) @ 10 Pa m<sup>3</sup>/h

Airflow (min.-max.) @ 10 Pa with additional airflow sleeve E-EMM<sup>2</sup> m<sup>3</sup>/h

Maximum opening area mm<sup>2</sup>

### Acoustics

Dn,e,w<sup>(1)(2)</sup> Acoustic attenuation @ max. opening dB

Adjustment factors (C ; Ctr) dB

Dn,e,w Acoustic attenuation<sup>(1)(3)</sup> with A-EMM canopy @ max. opening dB

Adjustment factors (C ; Ctr) dB

Dn,e,w Acoustic attenuation<sup>(1)(3)</sup> with A-EHA canopy @ max. opening dB

Adjustment factors (C ; Ctr) dB

### Accessories

Aeraulics sleeve (additional airflow)<sup>(4)</sup>

Oriented sleeve<sup>(4)</sup>

Standard canopy

Flat canopy

Acoustic canopy

Airflow controller canopy

### Characteristics

Weight g

Colours

Material (main)

### Installation

Recommended slots<sup>(5)</sup> mm

Existing slots<sup>(5)(6)</sup> mm

Fixing on windows

Fixing on rolling shutter casings

Wall installation

Destination rooms

	EMM <sup>2</sup> 5-35	EMM <sup>2</sup> 11-35	EMM <sup>2</sup> 24	EMM <sup>2</sup> 35
Standard code	EHM1275	EHM1285	EFM1289	EFM1292
Humidity sensitive	■	■	-	-
Closing device	□	-	-	-
Airflow (min.-max.) @ 10 Pa m <sup>3</sup> /h	5-35	11-35	24	35
Airflow (min.-max.) @ 10 Pa with additional airflow sleeve E-EMM <sup>2</sup> m <sup>3</sup> /h	22-45	26-45	36	45
Maximum opening area mm <sup>2</sup>	3600	3600	2500	3600
E-EMM <sup>2</sup> (ref. AEA1335)				
O-EMM <sup>2</sup> (ref. AEA1339)				
Standard canopy	AS	AS	AS	AS
Flat canopy	AP	AP	AP	AP
Acoustic canopy	A-EMM	A-EMM	A-EMM	A-EMM
Airflow controller canopy	AC	AC	AC	AC
Weight g	195	195	175	175
Colours	white / brown / oak / grey aluminium			
Material (main)	ABS, PS	ABS, PS	ABS, PS	ABS, PS
Recommended slots <sup>(5)</sup> mm	EMM <sup>2</sup> : 2 x (172 x 12) ; EMM <sup>2</sup> +E-EMM <sup>2</sup> : 2 x (172 x 16)			
Existing slots <sup>(5)(6)</sup> mm	EMM <sup>2</sup> : (250 x 15) ; EMM <sup>2</sup> +E-EMM <sup>2</sup> : (250 x 16)			
Fixing on windows	■	■	■	■
Fixing on rolling shutter casings	■	■	■	■
Wall installation	-	-	-	-
Destination rooms	living room / bedrooms			

<sup>(1)</sup>acoustic tests performed in CETIAT laboratory (test report CETIAT n°1663030-1).

<sup>(2)</sup>with non-acoustic canopies (AC, AS, AP) in standard version, without sleeve.

<sup>(3)</sup>standard version, without sleeve.

<sup>(4)</sup>E-EMM<sup>2</sup> and O-EMM<sup>2</sup> can't be used together.

<sup>(5)</sup>the slots ratings are external dimensions.

<sup>(6)</sup>these dimensions significantly reduce the airflow.

Note: The codes presented in this table are for white versions, without option (without closing device).

■ standard □ optional

## Airflow characteristics

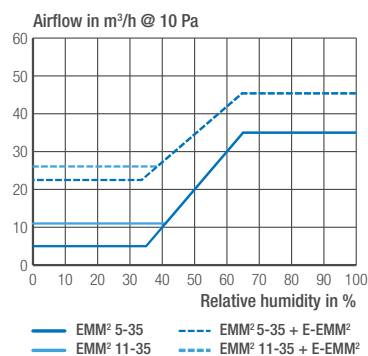

## Dimensions in mm

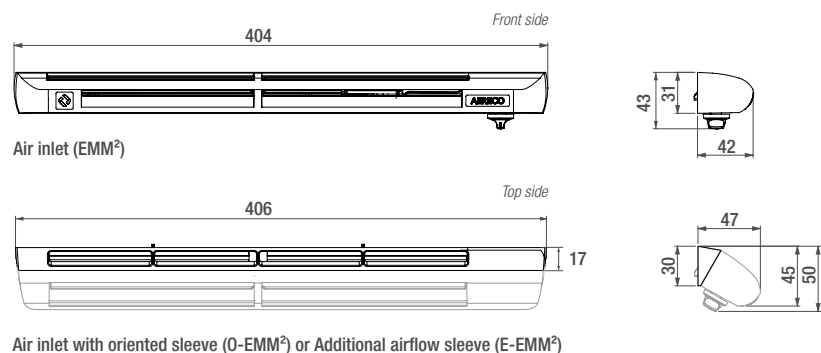

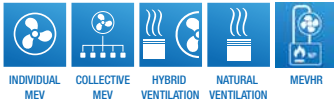

## EHA<sup>2</sup>

Acoustic humidity sensitive air inlet for windows



**Humidity sensitive system:** modulates the airflow according to the local relative humidity rate.



**Acoustic attenuation up to 42 dB** with accessories.



**Optional closing and opening device.**



**Slim profile for easy adaptation on windows.**



**Easy to maintain: no adjustment, simple yearly-dusting.**



### Stylish design, with maximum functions

The stylish design of the EHA<sup>2</sup> inlet enables perfect integration on most windows or rolling shutter casings. With the inclusion of high efficiency acoustic foam the product reaches an acoustic attenuation up to 42 dB when mounted with the special base and canopy. An optional device allows on demand manually closing or opening of the air inlet, complementing the humidity sensitive function available on the EHA<sup>2</sup>.

#### Oblique air jet for occupant comfort (1)

The oblique air jet of the EHA<sup>2</sup> skims the ceiling ensuring progressive heating of fresh air for the improved comfort of the occupants.

#### Optional opening and closing device (2)

This device is available on versions 5-35 (humidity sensitive) and 35 (without humidity control); it enables the occupant to choose between three modes: minimum, automatic (humidity sensitive) or maximum airflow. The device can be added after the product is installed.

#### Efficient protection against external noise (3)

When installed on its acoustic base and with acoustic external canopy (A-EHA), the EHA<sup>2</sup> air inlet offers great acoustic attenuation, up to 42 dB at maximum opening, which makes it one of the best products available on the market with an air cross section this size (3600 mm<sup>2</sup>).





# EHA<sup>2</sup> Acoustic humidity sensitive air inlet for windows

	EHA <sup>2</sup> 5-35 EAR200	EHA <sup>2</sup> 11-35 EAR202	EHA <sup>2</sup> 17-35 EAR203	EFA <sup>2</sup> 35 EAF309
<b>Standard code</b>				
<b>Airflow characteristics</b>				
Humidity sensitive	■	■	■	-
Closing + opening device*	□ (EAR201)	-	-	□ (EAF313)
Airflow (min.-max.) @ 10 Pa	m <sup>3</sup> /h 5-35	11-35	17-35	35
Max. opening area	mm <sup>2</sup> 3600	3600	3600	3600
<b>Acoustics</b>				
Dn,e,w (C; Ctr) Acoustic attenuation @ max. opening, air inlet	dB 37 (0; 0)	37 (0; 0)	37 (0; 0)	37 (0; 0)
Dn,e,w (C; Ctr) Acoustic attenuation @ max. opening, with A-EHA + E-EHA <sup>2</sup>	dB 42 (0; 0)	42 (0; 0)	42 (0; 0)	42 (0; 0)
<b>Accessories</b>				
Flat canopy	AP	AP	AP	AP
Acoustic canopy	A-EHA	A-EHA	A-EHA	A-EHA
Anti-insect canopy	AS	AS	AS	AS
Airflow controller canopy	AC	AC	AC	AC
Reinforced acoustic base	E-EHA <sup>2</sup>	E-EHA <sup>2</sup>	E-EHA <sup>2</sup>	E-EHA <sup>2</sup>
<b>Characteristics</b>				
Weight	g 271	271	271	250
Colours	white / brown / oak / grey			
Material (main)	PS, ABS	PS, ABS	PS, ABS	PS, ABS
<b>Installation</b>				
Slot	mm 2 x (172 x 12)			
Window installation	■	■	■	■
Rolling shutter casing installation	■	■	■	■
Destination room	bedroom / living room			

\*the device can be added as an accessory on EAR200 and EAR204 codes (complete external body + button + cam)

■ standard | □ optional

	Comb n.1	Comb n.2	Comb n.3	Comb n.4
EHA <sup>2</sup> air inlet, max. opening = 35 m <sup>3</sup> /h @ 10 Pa	■	■	■	■
Reinforced acoustic base (E-EHA <sup>2</sup> )	-	■	-	■
Acoustic canopy with insect grille (A-EHA)	-	-	■	■
Canopies (AP, AS or AC)	■	■	-	-
Dn,e,w (C; Ctr) Acoustic attenuation in dB	37 (0; 0)	39 (0; 0)	41 (0; -1)	42 (0; 0)

■ standard

Airflow characteristics

Dimensions in mm

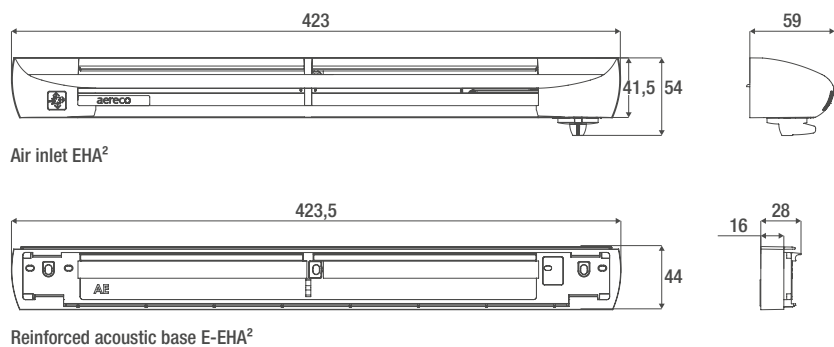
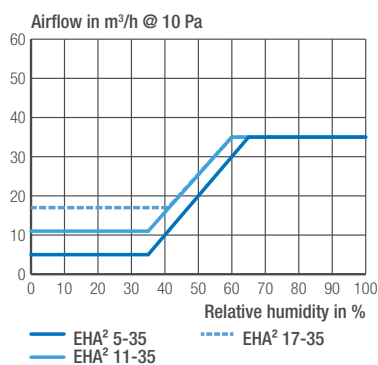

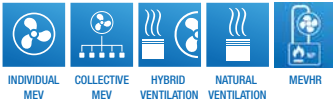

INDIVIDUAL MEV COLLECTIVE MEV HYBRID VENTILATION NATURAL VENTILATION MEVHR

NEW

## EAH<sup>2</sup>

Humidity sensitive air inlet for rolling shutter casings

Specially designed for rolling shutter casings.



**Humidity sensitive system:** modulates the airflow according to the local relative humidity rate.



**Optional closing and opening device.**



**Vertical air jet for the comfort of the occupant.**

**Air admission hole and shutter not visible from the occupant.**



**Easy to maintain: no adjustment, simple yearly-dusting.**



**Easy to install, no visible screws.**



### Flat design for perfect integration

With its flat design and its special airtightness sleeve, the EAH<sup>2</sup> air inlet is perfectly fitted to equip rolling shutter casings. The air is admitted in the room through the top of the product, the hole and shutter are not visible for the occupant. Its mechanical sensor modulates the airflow according to the local humidity, automatically and without electricity. An optional closing and opening device is available to manually fix the airflow to the minimum or maximum, if requested. A patented\* specific sleeve is proposed as accessory to increase the airflows of the standard versions.

### Aesthetic integration (1)

The flat and compact design of the EAH<sup>2</sup> and its non-visible top shutter favors its aesthetic integration, especially when mounted on rolling shutter casings. Its single frame front cover makes the painting easy to adapt to colored casings or windows.

### Improved airtightness through efficient accessories (2) (3)

A common issue with rolling shutter casings, notably when in PVC, is that the slot drilled on its façade for ventilation generates lateral leakages through the cells. To avoid this issue we have developed a specific sleeve, the T-EAH<sup>2</sup>, that ensures the continuity between the inner part of the shutter casing and the air inlet, optimizing the acoustic and aeraulics performance (2). A back seal (S-EAH<sup>2</sup>) is also proposed to adapt to specific shape of rolling shutter casing (light curve, unflat façade, etc.) (3). This accessory is stuck at the back of the air inlet (self-adhesive seal).

### Rolling shutter casings, but not only

Although first dedicated to rolling shutter casings, the EAH<sup>2</sup> can also equip windows with large top frames or transom windows.

\*patent pending



1

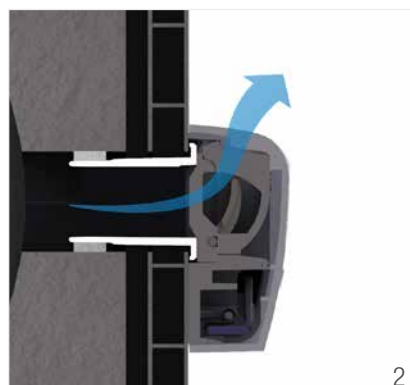

2



3



# EAH<sup>2</sup> Humidity sensitive air inlet for rolling shutter casings

**Air inlet**

**Standard code**

**Airflow characteristics**

Humidity sensitive

Closing + opening device

Airflow (min.-max.) @ 10 Pa standard version m<sup>3</sup>/h

Airflow (min.-max.) @ 10 Pa with additional airflow sleeve E-EAH<sup>2</sup> m<sup>3</sup>/h

**Acoustics**

Dn,e,w Acoustic attenuation @ max. opening, air inlet only dB

Adjustment factors (C ; Ctr) dB

Dn,e,w Acoustic attenuation @ max. opening, with specific canopy<sup>(1)</sup> dB

Adjustment factors (C ; Ctr) dB

Dn,e,w Acoustic attenuation<sup>(1)</sup> @ max. opening, with specific canopy and airtightness sleeve T-EAH<sup>2</sup> dB

Adjustment factors (C ; Ctr) dB

Dn,e,w Acoustic attenuation<sup>(3)</sup> @ max. opening, air inlet with rolling shutter casings dB

**Accessories**

Additional airflow sleeve

Airtightness sleeve<sup>(4)</sup>

Flat back seal

**Characteristics**

Weight g

Colours

Material (main)

**Installation**

Slot (space between centres) mm

Rolling shutter casing

Transom window

Wall<sup>(6)</sup>

Destination room

	EAH <sup>2</sup> 5-35	EAH <sup>2</sup> 11-35	EAH <sup>2</sup> 24	EAH <sup>2</sup> 35
Standard code	EHP1219	EHP1220	EHP1221	EHP1222
Humidity sensitive	■	■	-	-
Closing + opening device	□ (EHP1198)	-	-	-
Airflow (min.-max.) @ 10 Pa standard version m <sup>3</sup> /h	5-35	11-35	24	35
Airflow (min.-max.) @ 10 Pa with additional airflow sleeve E-EAH <sup>2</sup> m <sup>3</sup> /h	16-50	24-50	38	50
Dn,e,w Acoustic attenuation @ max. opening, air inlet only dB	33	33	33	33
Adjustment factors (C ; Ctr) dB	(0 ; 0)	(0 ; 0)	(0 ; 0)	(0 ; 0)
Dn,e,w Acoustic attenuation @ max. opening, with specific canopy <sup>(1)</sup> dB	35	35	35	35
Adjustment factors (C ; Ctr) dB	(0 ; 0)	(0 ; 0)	(0 ; 0)	(0 ; 0)
Dn,e,w Acoustic attenuation <sup>(1)</sup> @ max. opening, with specific canopy and airtightness sleeve T-EAH <sup>2</sup> dB	36	36	36	36
Adjustment factors (C ; Ctr) dB	(0 ; -1)	(0 ; -1)	(0 ; -1)	(0 ; -1)
Dn,e,w Acoustic attenuation <sup>(3)</sup> @ max. opening, air inlet with rolling shutter casings dB	between 42 and 49			
Additional airflow sleeve	E-EAH <sup>2</sup> (ref. AEA1216)			
Airtightness sleeve <sup>(4)</sup>	T-EAH <sup>2</sup> (ref. AEA1217)			
Flat back seal	S-EAH <sup>2</sup> (ref. AEA1218)			
Weight g	156	156	138	138
Colours	white (front color) dark grey (shutter and technical parts)			
Material (main)	ABS, PS	ABS, PS	ABS, PS	ABS, PS
Slot (space between centres) mm	without sleeve: 250 x 20 mm with E-EAH <sup>2</sup> or T-EAH <sup>2</sup> : 250 x 25 mm			
Rolling shutter casing	■	■	■	■
Transom window	■	■	■	■
Wall <sup>(6)</sup>	■	■	■	■
Destination room	bedroom / living room			

<sup>(1)</sup>acoustics tests performed in CETIAT laboratory (test report CETIAT n°1663030-2).

<sup>(2)</sup>with a specific canopy aimed at simulating the presence of rolling shutter casings.

<sup>(3)</sup>depending on the type of roller shutter casings. Tests realized in IFT Rosenheim laboratory.

<sup>(4)</sup>not compatible with the E-EAH<sup>2</sup>.

<sup>(6)</sup>needs the use of a duct adapted to the product.

■ standard | □ optional

**Airflow characteristics**

**Dimensions in mm**

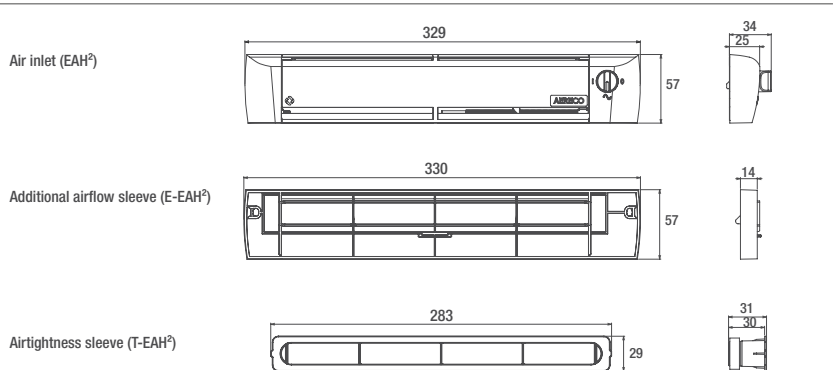
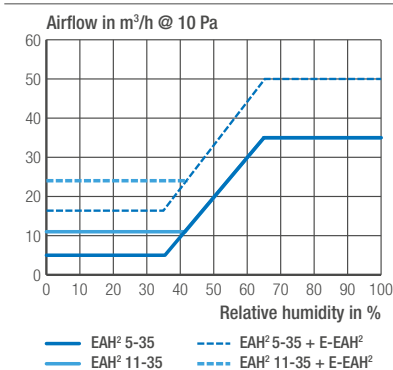

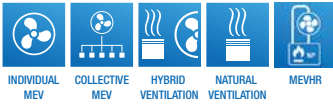

## EHT

Wall humidity sensitive air inlet



**Humidity sensitive system:** modulates the airflow according to the local relative humidity.



**Core drilling:** easy installation on the wall, ideal for refurbishment projects.



**Acoustic attenuation** up to 52 db with accessories.



**Easy to maintain:** no adjustment, simple yearly dusting, and readily accessible filters.



### The efficient wall mounted alternative

Designed to be installed on a wall or on a rolling shutter casing, the EHT humidity sensitive air inlet is an ideal alternative to window-mounted air inlets. It thus solves the problem of lack of space on windows. With accessories, it provides a high level of acoustic protection, up to 52 dB attenuation. A closing device and an airflow controller can be used to protect from cold weather and strong winds.

#### Easy wall mounting and efficient protection against outdoor noise (1)

Easy to install, in particular in refurbishment; the circular hole can be made using a core drill 100 mm in diameter – 125 mm for the complete acoustic kit. The complete acoustic kit (EHT + 125 mm duct + acoustic foam + acoustic canopy) can attain an acoustic attenuation of 52 dB, which places it among the best products available on the market.

#### Insect filter (2)

Nothing could be easier than cleaning the insect filter: once the EHT is unclipped, the removable F-EHT filter is readily accessible from the interior of the dwelling.

#### ACW: automatic airflow controller (3)

The ACW makes it possible to limit the maximum airflow to 40 m<sup>3</sup>/h in a duct 100 or 125 mm in diameter, even when the pressure exceeds 20 Pa (when there is wind for example).





# EHT

Wall humidity sensitive air inlet

**Standard code**

**Airflow characteristics**

Humidity sensitive

Closing device

Airflow (min.-max.) @ 10 Pa

Max. opening area

**Accessories / composition of the kits**

Air inlet (EHT)

ø100 mm tube, length 350 mm

Acoustic foam for ø100 mm tube

Acoustic foam for ø125 mm tube

Anti-insect removable filter (F-EHT)

Acoustic foam for A-EHT canopy

Anti-insect wall standard canopy (A-EHT-AM)

Wall standard canopy (A-EHT)

**Characteristics**

Weight

Colour

Material (main)

**Installation**

Spigot\*

Wall passage dimensions

Rolling shutter casing installation

Wall installation

Destination room

\*exists in bracket version

	EHT 5-40	EHT 11-40	EHT 17-40	Wall kit EHT 5-40 #1	Wall kit EHT 5-40 #2	Acoustic wall kit EHT 5-40	EFT24	EFT40
	EHT780	EHT957	EHT022	EHT816	EHT815	EHT969	EFT840	EFT026
Humidity sensitive	■	■	■	■	■	■	-	-
Closing device	■	-	-	■	■	■	-	-
Airflow (min.-max.) @ 10 Pa	m³/h 5-40	11-40	17-40	5-40	5-40	5-40	24	40
Max. opening area	mm² 4000	4000	4000	4000	4000	4000	4000	4000
Air inlet (EHT)	■	■	■	■	■	■	■	■
ø100 mm tube, length 350 mm	⊗	⊗	⊗	■	■	■	⊗	⊗
Acoustic foam for ø100 mm tube	⊗	⊗	⊗	-	-	■	⊗	⊗
Acoustic foam for ø125 mm tube	⊗	⊗	⊗	-	-	-	⊗	⊗
Anti-insect removable filter (F-EHT)	⊗	⊗	⊗	-	■	-	⊗	⊗
Acoustic foam for A-EHT canopy	⊗	⊗	⊗	-	-	■	⊗	⊗
Anti-insect wall standard canopy (A-EHT-AM)	⊗	⊗	⊗	■	-	■	⊗	⊗
Wall standard canopy (A-EHT)	⊗	⊗	⊗	-	■	-	⊗	⊗
Weight	g 489	489	489	862	962	988	382	382
Colour	white	white	white	white	white	white	white	white
Material (main)	PS	PS	PS	PS	PS	PS	PS	PS
Spigot*	mm ø100	ø100	ø100	ø100	ø100	ø100	ø100	ø100
Wall passage dimensions	mm	ø100 or ø125			ø100		ø100 or ø125	ø100
Rolling shutter casing installation	■	■	■	-	-	-	■	■
Wall installation	■	■	■	■	■	■	■	■
Destination room				bedroom / living room				

■ standard | ⊗ compatible

**Acoustics (combinations)**

EHT air inlet, max. opening = 40 m³/h @ 10 Pa

ø100 mm tube

Acoustic foam for ø100 mm tube

ø125 mm tube

Acoustic foam for ø125 mm tube

Acoustic foam for A-EHT canopy

A-EHT wall canopy

Dn,e,w (C ; Ctr) Acoustic attenuation in dB

Note: acoustic results for recommended slots.

	Comb n.1	Comb n.2	Comb n.3	Comb n.4	Comb n.5	Comb n.6
EHT air inlet, max. opening = 40 m³/h @ 10 Pa	■	■	■	■	■	■
ø100 mm tube	■	■	■	■	-	-
Acoustic foam for ø100 mm tube	-	■	-	■	-	-
ø125 mm tube	-	-	-	-	■	■
Acoustic foam for ø125 mm tube	-	-	-	-	■	■
Acoustic foam for A-EHT canopy	-	-	■	■	-	■
A-EHT wall canopy	■	■	■	■	■	■
Dn,e,w (C ; Ctr) Acoustic attenuation in dB	33 (0 ; 0)	42 (0 ; -2)	40 (0 ; -2)	45 (0 ; -2)	49 (-1 ; -4)	52 (-1 ; -4)

■ standard

**Airflow characteristics**

**Dimensions in mm**

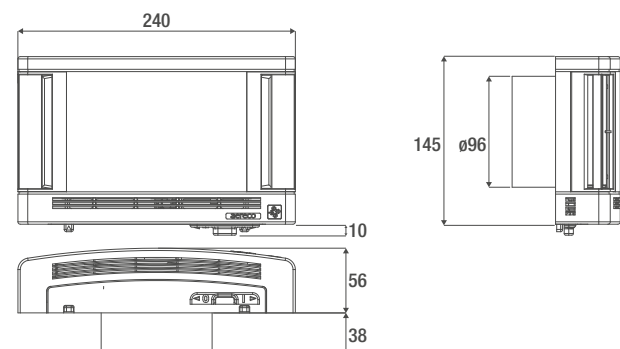
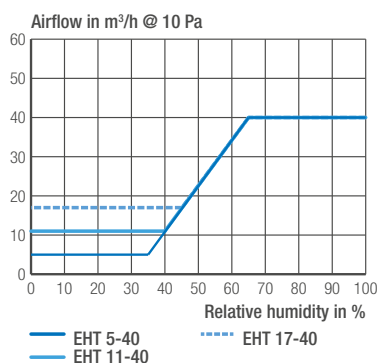



## EXTERNAL CANOPIES

Protects the internal structure of the window against water infiltration.



Protects the dwelling from flying insects.

Ensures the aesthetic balance of frontage and windows.



Helps protect against noise (acoustic canopies).



### Aereco canopies: attractive, easy-to-install protection

External air inlet canopies protect the elements of the frame (windows, casings) hosting the air passage holes against bad weather and water infiltration. Their role is also aesthetic: they blend in perfectly with the frontage and windows. They can also perform such functions as soundproofing, insect protection, etc.

### Patented design to control the maximum airflow on the AC canopy (1, 2)

The AC external canopy is designed to automatically limit the airflow in the event of high pressure, thanks to a patented device. The mechanism comprises a silicon flap that moves according to the airflow. It automatically reduces the air cross-section when the airflow becomes too high.

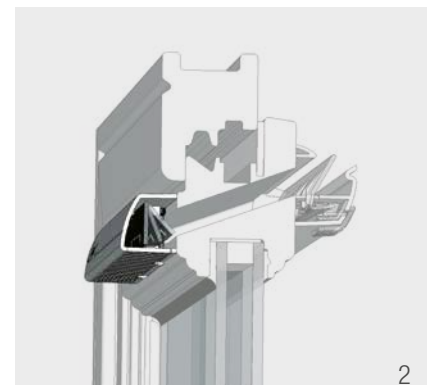
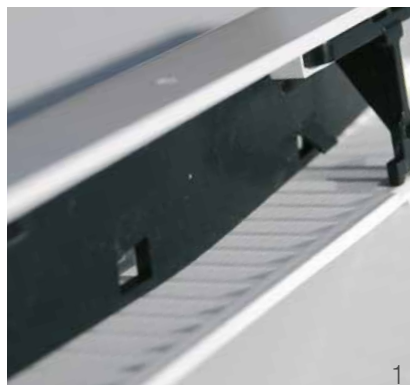



# WINDOW CANOPIES

	AS AEA731	AP AEA098	AC AEA100	A-EHA AEA851	A-EMM AEA833
<b>Standard code</b>					
<b>Description</b>	standard canopy with insect grille	flat canopy with insect grille for low spaces	airflow controller canopy with insect grille	acoustic canopy with insect grille	acoustic canopy with insect grille
<b>Air inlet compatibility</b>	all Aereco window air inlets	all Aereco window air inlets	all Aereco window air inlets	EHA <sup>2</sup> / all Aereco window air inlets	EMM <sup>2</sup> / all Aereco window air inlets
<b>Characteristics</b>					
<b>Weight</b>	g 38	30	75	216	174
<b>Colours</b>	white/oak/brown	white/oak/brown	white/oak/brown	white/oak/brown	white/oak/brown
<b>Material (main)</b>	ABS ASA	PVC	PVC (flap in silicon)	PVC	PVC
<b>Anti-insect grille / screen</b>	■	■	■	■	■
<b>Installation</b>					
<b>Slot</b>	mm depends on air inlet	depends on air inlet	depends on air inlet	depends on air inlet	depends on air inlet
<b>Window installation</b>	■	■	■	■	■
<b>Rolling shutter casing installation</b>	■	■	■	■	■

■ standard



# WALL CANOPIES AND ACCESSORIES

	A-EHT AEA775	A-EHT AM AEA778	F-EHT AEA774	ACW AEA064	Adaptator for ACW in ø125 mm tube AEA086
<b>Standard code</b>					
<b>Description</b>	wall canopy	wall canopy with insect grille	removable filter for ø100 mm tube	airflow controller: limits the airflow to 40 m <sup>3</sup> /h	adaptor for ø125 mm tube
<b>Air inlet compatibility</b>	EHT, round wall air inlets	EHT, round wall air inlets	EHT, ø100 mm tube	EHT, round wall air inlets	EHT, round wall air inlets
<b>Characteristics</b>					
<b>Weight</b>	g 243	243	36	30	57
<b>Colours</b>	white	white	white	white	grey
<b>Material (main)</b>	PVC	PVC	PE	PVC, silicon	PVC + rubber
<b>Anti-insect grille / screen</b>	-	■	■	-	-
<b>Installation</b>					
<b>Tube</b>	mm ø100*	ø100*	ø100	ø100 ø125 (with adaptor ref. AEA086)	ø125
<b>Installation in external wall tube</b>	■	■	■	■	■

\*possibility of covering tube up to ø125 mm.

■ standard

Airflow characteristics

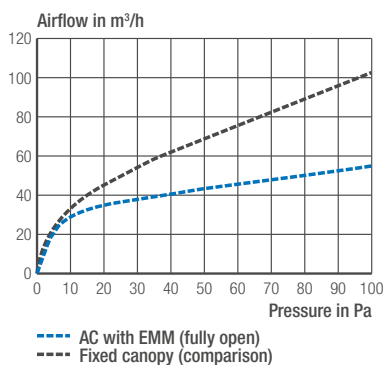

Dimensions in mm

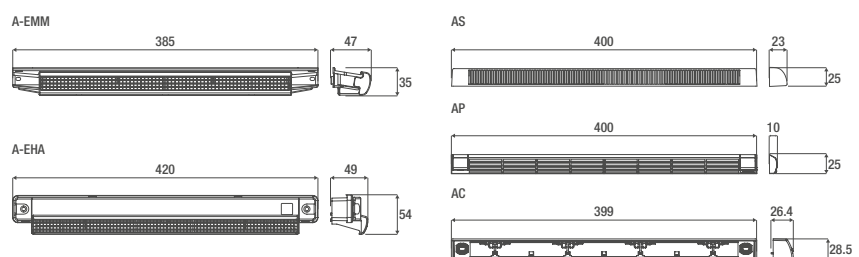

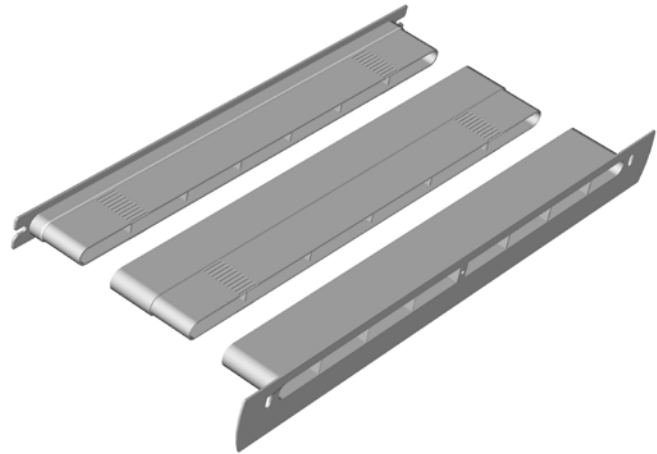
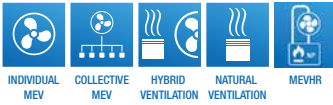

## E-TFR

Window telescopic sleeve



Avoids the internal cooling of the window (protects from condensations).



Keeps the thermal performance of the window.



Optimizes the acoustics of the air inlet (no noise leakage).

Ensures the air section needed.

Adapts to the thickness of the window.



Aesthetic integration: designed for Aereco air inlets.



Easy installation: fixing through the holes of Aereco air inlets and canopies.

### Protection of the window and guarantee of airflows

By ensuring the continuity of the airflow from the outside canopy to the air inlet, the E-TFR protects the interior of the window and avoids cooling to prevent internal condensation. Its implementation guarantees sufficient air passage for ventilation of the room. The window sleeve is composed of two interlocking parts (a canopy side and an air inlet side) plus an optional extension to cover a wide range of window thicknesses, from 50 to 130 mm. 3 versions are available to fit perfectly to the different Aereco air inlets to ensure a perfect airtightness and aesthetic finish (EMM / EHA version, EMM<sup>2</sup> and EHA<sup>2</sup> version).

#### Avoids the internal cooling of the window (1)

By ensuring the continuity of the flow from the outside canopy up to the indoor air inlet, the window telescopic sleeve E-TFR prevents the cooling of the window inner frame. It thus reduces the risk of condensation inside and keeps the thermal performance of the window, notably for aluminium windows.

#### Adapts to most of the window profiles, as thin as thick (2)

With two interlocking parts and a telescopic extension available as an accessory, the E-TFR adapts to window profiles from 50 to 130 mm thickness. Included clips also allow to ensure the correct connection of the components within the profile.

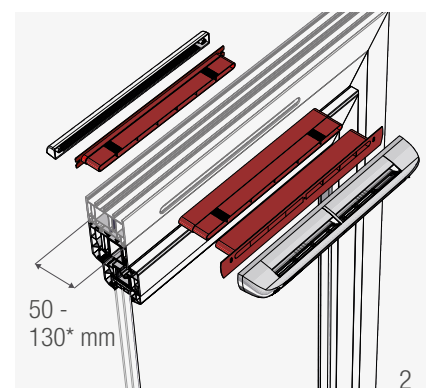
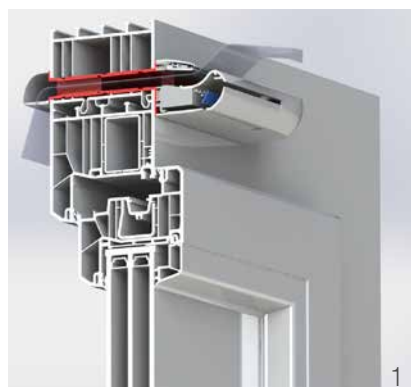

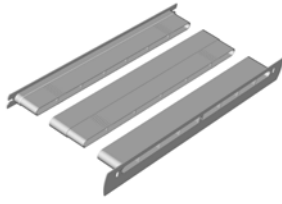

# E-TFR Window telescopic sleeve

	<b>E-TFR EMM</b>	<b>E-TFR EHA<sup>2</sup></b>	<b>E-TFR EMM<sup>2</sup></b>	<b>E-TFR s</b>
<b>Standard code</b>	<b>AEA1150</b>	<b>AEA1151</b>	<b>AEA1429</b>	<b>AEA1152</b>
<b>Description</b>	kit window sleeve for EMM	kit window sleeve for EHA <sup>2</sup>	kit window sleeve for EMM <sup>2</sup>	extension sleeve for E-TFR
Air inlets compatibility	EMM EHA	EHA <sup>2</sup>	EMM <sup>2</sup>	EMM EHA EHA <sup>2</sup> EMM <sup>2</sup>
Opening area	3600	3600	3600	3600
<b>Characteristics</b>				
Weight	100	109	100	52
Colour	white	white	white	white
Material	PS	PS	PS	PS
<b>Installation</b>				
Compatible window thickness	50 to 71 mm	50 to 71 mm	50 to 71 mm	81 to 130 mm (AEA1150 or AEA1151 required)*
Slots to drill	L x h = 359 x 16 mm (minimum dimensions)			
Configuration	fixed part - fixed part or mobile part - mobile part			
Compatible type of windows	PVC, aluminium, wooden, mixt			
Mounting	introduce the components into the slot, support surface into contact with the window. fixed by the screws of the canopy and of the air inlet.			

\*the window profiles whose thickness is between 71 and 81 mm require a cutting of the telescopic extension and of the part in contact with the air inlet. Beyond 120 mm, a silicone seal between each component is recommended to ensure the tightness of the assembly.

Dimensions in mm

E-TFR EHA<sup>2</sup> (inlet part)

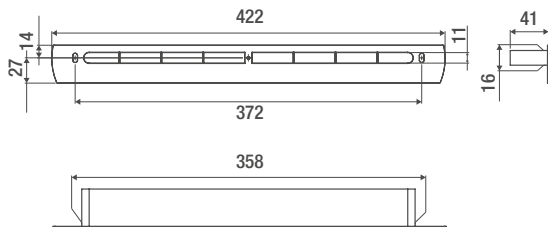

E-TFR EMM<sup>2</sup> (inlet part)

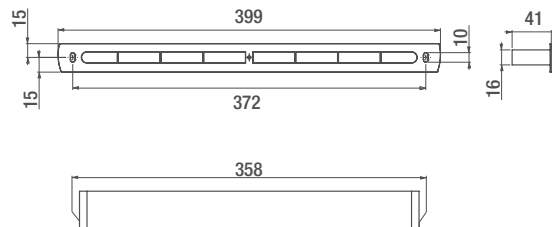

Canopy part (common)

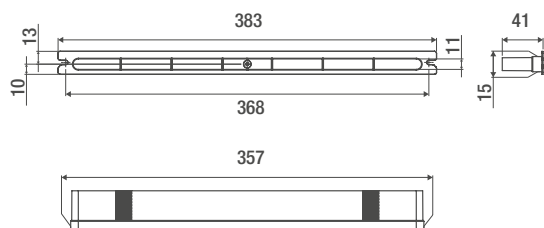

E-TFR s (extension sleeve)

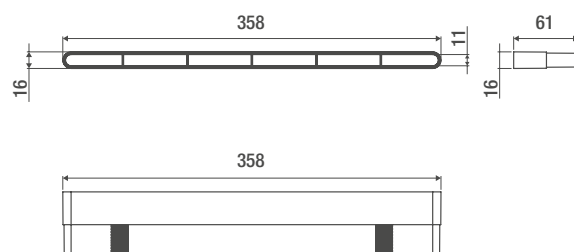

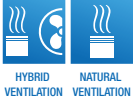

## G2H

Multi-controlled exhaust unit for natural and hybrid ventilation



**Fully automatic operation:** exhaust airflow according to various parameters, such as humidity or presence.



**Pull cord, switch, and remote auxiliary airflow control versions.**



**Indoor air quality and energy saving thanks to automatic airflow control.**

**Large air cross-section optimised for natural ventilation or hybrid ventilation, in new buildings or renovations.**



**Fits directly on all types of air ducts (collective or individual, concrete or metal “shunts”).**



**Completely silent operation.**



### A unique solution precisely optimised for natural and hybrid ventilation

The G2H is the first exhaust unit precisely optimised for natural (passive stack) and hybrid ventilation, in both new buildings and renovations. By providing both automatic control of the airflow according to needs and auxiliary airflows (manual or automatic), the G2H exhaust unit advantageously combines energy efficiency and indoor air quality. It offers a very large air cross-section to ensure the airflow even at a very low pressure, from 2 Pa. It is particularly easy to install, since it fits perfectly on collective or individual ducts designed for natural or hybrid ventilation.

### A smart and unique exhaust unit

The numerous modules available on the G2H exhaust unit meet various needs and occupancy modes in dwellings: humidity controlled to remove excess moisture quickly, presence detection, and even remote control to exhaust odours are some of the actuation modes available to optimise, at all times and in every room, both indoor air quality and energy consumption.

### An optimised solution to improve building energy performance

With settings precisely optimised, the G2H exhaust unit is an especially satisfying response to anyone wishing to combine energy efficiency, quiet operation, and ease of implementation, whether in a new or a renovated building.

### A very large air cross-section to accommodate low pressures

With an air cross-section of up to 163 cm<sup>2</sup> at maximum opening, the G2H exhaust unit ensures airflows even at very low pressure, from 2 Pa.





# G2H

Multi-controlled exhaust unit for natural and hybrid ventilation

	G2H h	G2H hp	G2H hi	G2H hc	G2H hrc	G2H p	G2H i	G2H c	G2H rc
	G2H 1064EX	G2H 1065EX	G2H 1066EX	G2H 1067EX*	G2H 1068EX	G2H 1069EX	G2H 1070EX	G2H 1071EX	G2H 1072EX
<b>Standard code</b>									
<b>Airflow characteristics</b>									
Humidity sensitive	■	■	■	■	■	-	-	-	-
Boost airflow activated by presence detection*	-	■	-	-	-	■	-	-	-
Boost airflow activated by switch*	-	-	■	-	-	-	■	-	-
Boost airflow activated by remote control*	-	-	-	-	■	-	-	-	■
Boost airflow activated by pull cord*	-	-	-	■	-	-	-	■	-
Airflow**@ 10 Pa	12-72	12-72	12-72	12-72	12-72	12	12	12	12
Humidity sensitive [boost]		[160]	[160]	[160]	[160]	[72]	[72]	[72]	[72]
<b>Acoustics</b>									
Sound pressure level Lp @ 2 m max. RH, 10 / 25 Pa					22 / 36				
Sound pressure level Lp @ 2 m boost airflow, 10 Pa / 25 Pa					23 / 35				
<b>Supply</b>									
9 V battery	-	■	■	-	-	■	■	-	-
12 VAC supply with specific transformer code CAL195EX	-	□	□	-	■ (included)	□	□	-	■ (included)
<b>Characteristics</b>									
Colour	white	white	white	white	white	white	white	white	white
Material (main)					PS and ABS				
<b>Installation</b>									
Duct compatibility									
Destination room	bathroom	bathroom with WC	kitchen	kitchen	kitchen	WC	WC	WC	WC

\*boost timer = 20 minutes

\*\*airflow for [125 x 200] mm hole

Note: other G2H versions available - please consult us.

■ standard | □ optional

Airflow characteristics

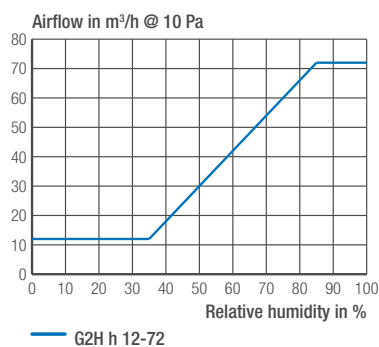

Dimensions in mm

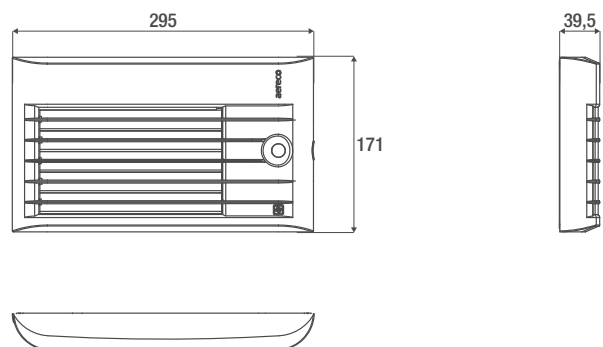

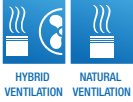

## GHN

Humidity sensitive exhaust unit for natural and hybrid ventilation



**Humidity sensitive system:** modulates the airflow according to the local relative humidity.



**Easy to install:** directly replace the old ventilation exhaust units, without modification of the hole.



**Easy to maintain:** no adjustment, simple yearly dusting.



### Naturally effective extraction

How can wet rooms be effectively ventilated with allowance for the requirements and specific needs of natural (passive stack) ventilation? The GHN humidity sensitive exhaust unit is the perfect solution, as it adapts its airflow to variations in relative humidity. Its dimensions are compatible with the air cross-section of natural ventilation ducts and its design allows for perfect integration in bathroom and toilets.

### Suited to all situations (1)

Four removable plates on the back of the GHN make it adaptable to different dimensions and hole configurations when installed in a bracket version. It is also possible to increase the maximum airflow up to 100 m<sup>3</sup>/h for a pressure of 10 Pa.

### Simple mechanism for greater longevity (2)

The GHN has a simple and robust humidity sensor that requires no maintenance and will retain all of its qualities for many years.

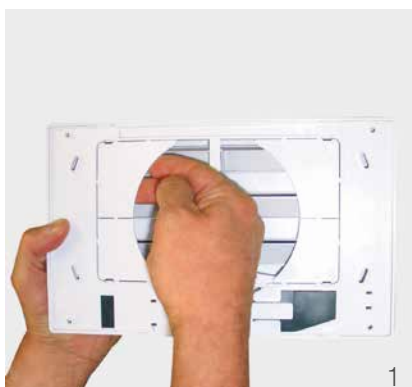



# GHN

Humidity sensitive exhaust unit for natural and hybrid ventilation

		GHN spigot GHN736	GHN bracket GHN735	GFN spigot GFN850	GFN bracket GFN849
<b>Standard code</b>					
<b>Airflow characteristics</b>					
Humidity sensitive		■	■	-	-
Airflow (min.-max.) @ 10 Pa	m <sup>3</sup> /h	15-75	15-75 (100)*	100	100
<b>Characteristics</b>					
Weight	g	315	270	238	174
Colour		white	white	white	white
Material (main)**		ABS	ABS	ABS	ABS
<b>Installation</b>					
Duct compatibility	mm	ø125	min. 125 x 105	ø125	min. 125 x 105
Destination room			bathroom / toilets / bathroom with toilets / kitchen		

\*maximum airflow obtained by removing 4 plates at the back of the product.  
 \*\*for products manufactured from the end of June 2017.

■ standard

Airflow characteristics

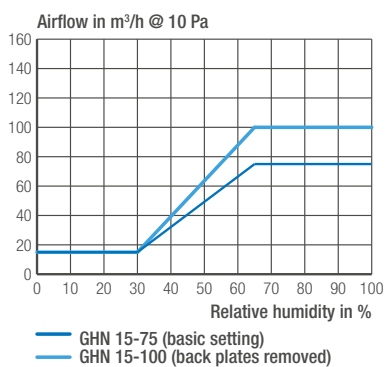

Dimensions in mm

GHN bracket version

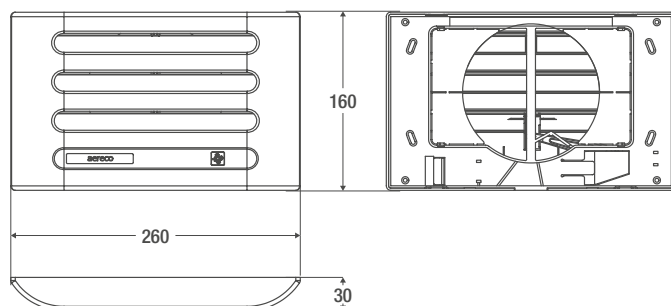

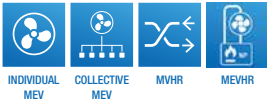

## BXC

Demand controlled exhaust unit for MEV



Humidity sensitive, presence detector and switch versions: modulates the airflow according to the various needs of the dwelling.

Airflow “+”: possibility of setting the airflow levels at installation: up to +50 m<sup>3</sup>/h on the max. airflow.



Advanced special versions: CO<sub>2</sub>, VOC, and remote control versions.



Silent working: quiet auxiliary airflow activation.

Battery indicator: buzzer to indicate low battery level.

Pressure plug: allows pressure measurement to determine the airflow.



Easy to maintain: removable shutter case and front cover for easy cleaning.



### A multifunctional exhaust unit to optimise indoor air quality and energy efficiency in MEV applications

The BXC incorporates all of the functions one could want in an air exhaust unit: various activation modes, such as humidity sensitive, presence detection, switch, and even CO<sub>2</sub> are available to adapt the ventilation to occupants' needs. The exhaust airflow is automatically modulated, in silent operation. The range of variable airflows can be set at installation to meet special needs, or to compensate for a lack of pressure; commissioning is also facilitated by the presence of a pressure plug, which allows measurement and easy calculation of the airflow.

#### Airflow “+”: airflows can be set at time of installation (1)

The BXC lets you set the airflow according to the pressure available or to specific regulation requirements. The fixed shutter can be set to 6 positions, with an average step of +10 m<sup>3</sup>/h (maximum = +50 m<sup>3</sup>/h).

#### Pressure plug to help commissioning (2)

The built-in pressure plug makes it easy to measure the pressure using a manometer, then calculate airflow using a table in the installation instructions.

#### Advanced special versions (3)

The BXC was the first exhaust unit in the world offering the possibility of having built-in CO<sub>2</sub> and VOC sensors, for example. These innovations are especially well suited to applications in schools, offices, gymnasiums, mobile homes, etc. A remote control version is also available.

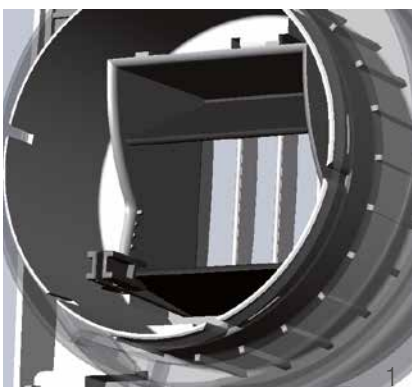



# BXC

Demand controlled exhaust unit for MEV

		BXC h	BXC p	BXC hi	BXC hp	BXC co <sup>2</sup>	BXC voc
		BXC211	BXC213	BXC212	BXC272	BXC401	BXC402
<b>Standard code</b> (other versions available, please contact us.)							
<b>Airflow characteristics</b>							
Humidity sensitive		■	-	■	■	-	-
Boost airflow		-	■	■	■	■	■
Boost airflow activated by switch		-	-	■	-	-	-
Boost airflow activated by presence detection		-	■	-	■	-	-
Other activation modes		-	-	-	-	CO <sub>2</sub> level	VOC level
Airflow @ 100 Pa (min.-max.) <sup>(1)</sup>	m <sup>3</sup> /h	12-80	12-80	12-80	12-80	12-80	12-80
Airflow '+' - maximum available airflow @ 100 Pa <sup>(2)</sup>	m <sup>3</sup> /h	130	130	130	130	130	130
<b>Acoustics</b>							
Sound pressure level Lp @ 2 m, 100 Pa, 80 m <sup>3</sup> /h, min. airflow '+' setting	dB(A)	28.3					
Dn,e,w (C, Ctr) Acoustic insulation, RH = 65 %, min. airflow '+' setting	dB	57 (-2 ; -4)	-	57 (-2 ; -4)	57 (-2 ; -4)	-	-
<b>Power supply</b>							
2 x 1.5 V AAA LR03 batteries (not supplied)		-	☒	☒	☒	-	-
Buzzer (low battery charge)		-	■	■	■	-	-
12 VAC supply with specific transformer (ref. CAL261)		-	☒	☒	☒	■ (CAL included)	■ (CAL included)
<b>Characteristics</b>							
Colour		white	white	white	white	white	white
Material (main)		PS / ABS	PS / ABS	PS / ABS	PS / ABS	PS / ABS	PS / ABS
<b>Installation</b>							
Round duct compatibility with integrated spigot	mm	ø100	ø100	ø100	ø100	ø100	ø100
Round duct compatibility with accessory spigot <sup>(3)</sup>	mm	ø125	ø125	ø125	ø125	ø125	ø125
Round duct compatibility - bracket version (min.-max.)	mm	ø85 - ø90	ø85 - ø90	ø85 - ø90	ø85 - ø90	ø85 - ø90	ø85 - ø90
Rectangular duct compatibility - bracket version (min.-max.)	mm	67 x 60 67 x 66	67 x 60 67 x 66	67 x 60 67 x 66	67 x 60 67 x 66	67 x 60 67 x 66	67 x 60 67 x 66
<b>Other functions</b>							
Pressure plug		■	■	■	■	■	■

Note: airflows given for a ø100 mm duct

■ standard / included | ☒ compatible

<sup>(1)</sup>default setting.

<sup>(2)</sup>airflow '+': the airflow can be increased from +10 m<sup>3</sup>/h to +50 m<sup>3</sup>/h (6 available positions). This function can be used to adapt to lower pressures or to specific regulations imposing higher airflows. Standard is position 0 (minimum airflow = 12 m<sup>3</sup>/h @ 100 Pa).

<sup>(3)</sup>delivered in specific versions or available as accessory (ref. AEA317).

Airflow characteristics

Dimensions in mm

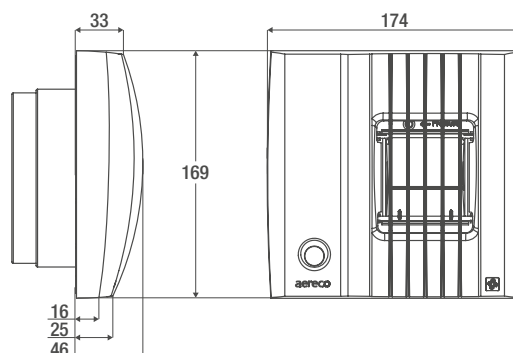
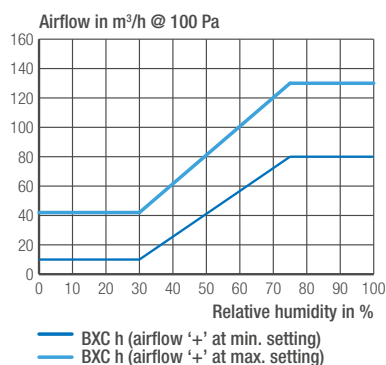



## GBP

Humidity sensitive exhaust unit  
for natural and hybrid ventilation



Humidity controlled or pull cord  
activated airflow.

Low-pressure solution optimised  
for energy performance, with many  
versions available for different  
types of housing and rooms.



Completely silent operation.



Suitable for individual or  
collective natural ventilation  
ducts using an adapter plate.



Easy cleaning: removable shutter  
box and front cover.



### The ideal solution to refurbish ventilation while keeping low-pressure operation

Specially adapted to work at low pressure, the GBP humidity sensitive exhaust unit is an ideal solution for the renovation of ventilation ductwork initially operating in natural ventilation. The GBP exhaust unit is available in several versions activated by a humidity sensitive sensor or by a pull cord, for implementation on collective or individual air ducts. Operating at pressures from about 15 to 30 Pa, it can be connected to a low-pressure exhaust fan or to a hybrid fan (VBP, VBP+). In addition to making it unnecessary to measure duct air-tightness, low-pressure operation offers the advantage of consuming considerably less energy than conventional mechanical exhaust ventilation, with quiet operation.

### The ideal way to refurbish with low-pressure ventilation

The GBP exhaust unit is available in several versions, with airflow controlled by a fully automatic humidity sensor or by pull cord. Constant airflow versions are also available.

### Easy to adapt to individual or collective natural ventilation ducts

Thanks to an adapter plate available as an accessory, the GBP exhaust unit fits easily over the holes of old ventilation exhaust units.





# GBP

Humidity sensitive exhaust unit for natural and hybrid ventilation

	GBP h 10-42 GBP446	GBP h 20-55 GBP444	GBP c 10/30 GBP443	GBP 30 GBP480	GBP 15 GBP479
<b>Standard code</b>					
<b>Airflow characteristics</b>					
Humidity sensitive	■	■	-	-	-
Boost airflow activated by pull cord*	-	-	■	-	-
Airflow (min.-max.) @ 15 Pa	10-42	20-55	10-30	30	15
<b>Characteristics</b>					
Colour			white		
Material (main)			PS		
<b>Installation</b>					
Connexion			bracket**		
Duct compatibility**	mm on holes from l x h = [90 x 150] to l x h = [140 x 260]				
Destination room	kitchen or bathroom	kitchen or bathroom	WC	WC	WC

\*boost airflow timer = 30 minutes

\*\*refurbishment may require a BAHIA BH Aldes according to dimensions of the hole

Note: other settings (airflow / relative humidity) exist - please consult us.

■ standard

Airflow characteristics

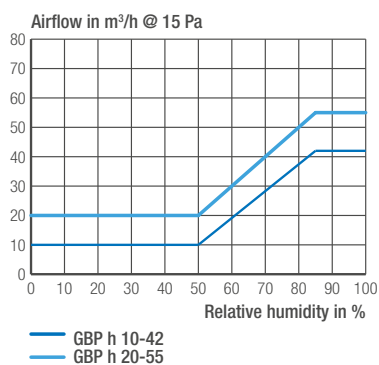

Dimensions in mm

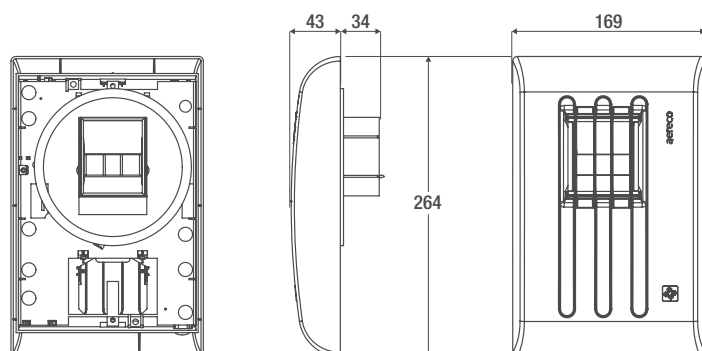

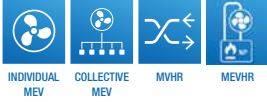

## TDA

Exhaust unit with presence detection for MEV



**Presence detection:** starts the basic airflow as soon as a presence is detected.



**Easy to maintain:** removable grille for easy cleaning.



**Easy adjustment of the basic airflow** according to the number of occupants.

**Battery (9 V) or 12 VAC supply.**

**Output to relay (specific version) to operate external device (light, etc.) upon presence detection.**

### Detecting presence to adapt the airflow

TDA exhaust units directly adapt the exhaust airflow to the presence detected in the room. A simple initial adjustment of the basic airflow according to the usual number of occupants is sufficient to ensure permanent air quality. When the room is unoccupied, the airflow is automatically reduced, allowing savings averaging 50% on thermal losses due to ventilation.

#### Precise detection of presence (1)

The presence detection module comprises a pyroelectric sensor that detects infrared radiation focused by a Fresnel lens. With a 4-meter range and a 100° angle of detection, this is very effective. The infrared radiation focused on the sensor is continually analysed; when a variation is perceived, a signal is sent to the electronic board, which analyses it and then activates the motor controlling the opening of the exhaust unit shutters. The detection module can discriminate between human heat and heaters or lights. The “basic” airflow is started as soon as a presence is detected: the TDA returns to the reduced airflow 20 minutes after the last detection. When the room is empty, this saves up to 50% heating energy (compared to constant ventilation with the same air quality).

#### A simple adjustment determines the basic airflow (2)

A cursor can be used at any time to set the number of people in the office, which determines the basic airflow activated by the detection process (from 25 to 100 m<sup>3</sup>/h).

#### Output to relay

A specific version has an output to operate a relay (6 VDC, I<sub>max</sub>. 100 mA), which can be used to activate an external device such as the light, for example.





# TDA Exhaust unit with presence detection for MEV

	TDA 9V TDA874	TDA 12V TDA873	TDA 12V TDA930	TDF TDF875
<b>Standard code</b>				
<b>Airflow characteristics</b>				
Humidity sensitive	-	-	-	-
With boost airflow	■	■	■	fix
Boost airflow activated by presence detection	■	■	■	-
Min. airflow @ 100 Pa	m <sup>3</sup> /h 5	m <sup>3</sup> /h 5	m <sup>3</sup> /h 5	25 / 50 / 75 / 100
Max. airflow @ 100 Pa	m <sup>3</sup> /h 25 / 50 / 75 / 100	m <sup>3</sup> /h 25 / 50 / 75 / 100	m <sup>3</sup> /h 25 / 50 / 75 / 100	-
<b>Acoustics</b>				
Sound power level Lw @ 25 m <sup>3</sup> /h - 100 Pa	dB(A) 30	dB(A) 30	dB(A) 30	dB(A) 30
Sound power level Lw @ 100 m <sup>3</sup> /h - 100 Pa	dB(A) 33.3	dB(A) 33.3	dB(A) 33.3	dB(A) 33.3
<b>Power supply</b>				
Battery 9V DC	■	-	-	-
12 VAC supply (integrated)	-	■	■	-
<b>Characteristics</b>				
Weight	g 250	g 250	g 250	g 250
Colour	white	white	white	white
Material (main)	PS	PS	PS	PS
LED detection signal	-	■	■	-
Output for relay connection* (relay = 6 VDC, I <sub>max.</sub> = 100 mA)	-	-	■	-
<b>Installation</b>				
Duct compatibility	mm ø125	mm ø125	mm ø125	mm ø125
Destination room		office / meeting room (1 TDA for 4 people) / toilets		

\*allows connection to an external relay to control a light for example

■ standard

Airflow characteristics

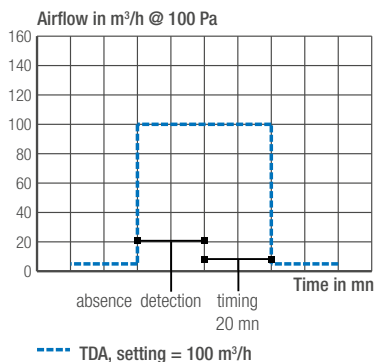

Dimensions in mm

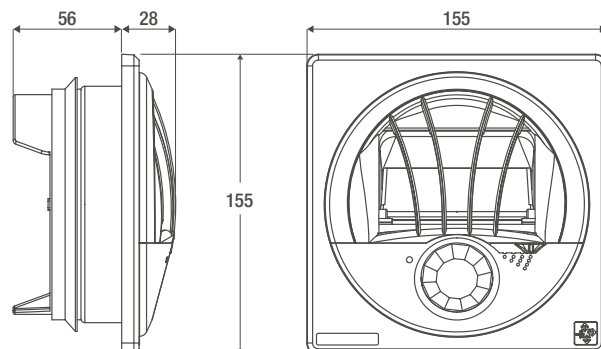



## V2A

Acoustic whole-house fan – 2 rooms



**Silent:** only 33 dB(A)\*.



**Low energy consumption:** only 5.5 W @ 40 m<sup>3</sup>/h.



**Constant pressure:** fitted to demand controlled exhaust units.



**Easy to install:** flat and compact, directly installed in inhabited space.

**12 VAC output to supply electrical exhaust units.**

**Outlet 100 mm in diameter.  
Inlets 80 mm.**



**Easy to maintain:** simple yearly cleaning of a filter, easily accessible without tools.



### Discretion and comfort in sanitary installations

The best ventilation is ventilation nobody notices. You will not notice the V2A fan: quiet, easily hidden in a wall cupboard or in the loft space. You will simply appreciate the quality of the air renewal. Installed in apartments or in individual houses, the V2A can connect up to two demand controlled exhaust units located in bathrooms and toilets. As far as consumption is concerned, it is as energy-efficient as it is discreet with its low-consumption EC-motor.

### An intelligent EC-motor

The speed of the EC-Motor (Electronic Commutation Motor) of the V2A is controlled by an electronic board. The motor speed, associated with a special wheel, holds the pressure at 80 Pa to keep the airflow proportional to the variable cross section of the two connected demand controlled exhaust units. This keeps power consumption and noise emissions to a minimum.

### Installed close to the occupant

Because it is silent and compact, the V2A can be installed directly in the living space, in a wall cupboard, a loft volume, etc. Maintenance is facilitated by its proximity to the occupant, and also by the removable filter, easily reached by opening the lid, with no need of a tool.

### 12 VAC output for exhaust units with electrical boost airflow

The V2A fan includes a 12 VAC transformer to supply up to two exhaust units equipped with an electrically activated airflow.

\*@ 40 m<sup>3</sup>/h





# V2A Acoustic whole-house fan - 2 rooms



**Standard code**

**Airflow characteristics**

Max. airflow @ 80 Pa	m³/h
Max. pressure	Pa

**Acoustics**

Sound pressure level Lp (r = 2 m) [airflow in m³/h]	dB(A)
---	-------

**Electrics**

Power supply	
Motor type	
Power consumption [airflow in m³/h]	W
Ingress Protection rating	

**Characteristics**

Weight	kg
Colour	
Material (main)	
Dimensions	mm

**ErP specifications**

SEC, Climat	
ErP Classification from 01/01/2016	
ErP information	
ErP label	

**Installation**

Max. available duct connections**	
Max. connectable exhaust units (airflow capacity)	
Inlet	mm
Outlet	mm
Installation	

**Maintenance**

Filter	
Cleaning	
Removable electrical part	

**Operation**

Direct-drive impeller	
Speed	RPM

**Other functions**

12 VAC output for 2 boost airflow exhaust units supply	
--	--

**V2A 100V**

**V2A041\***

**V2A 230V**

**V2A032**

Max. airflow @ 80 Pa	m³/h	80	80
Max. pressure	Pa	80	80
Sound pressure level Lp (r = 2 m) [airflow in m³/h]	dB(A)	32 [20]; 33 [80]	32 [20]; 33 [80]
Power supply		100 VAC / 50 Hz	230 VAC / 50 Hz
Motor type		EC (Electronic commutation)	EC (Electronic commutation)
Power consumption [airflow in m³/h]	W	5.5 [40]; 13 [80]	5.5 [40]; 13 [80]
Ingress Protection rating		IP30	IP30
Weight	kg	3.9	3.9
Colour		grey (light and dark)	grey (light and dark)
Material (main)		PS	PS
Dimensions	mm	390 x 390 x 176	390 x 390 x 176
SEC, Climat		cold: -53,31 / average: -25, 63 / warm: -10,13	
ErP Classification from 01/01/2016		not applicable	
ErP information		available on <a href="http://www.aereco.com">www.aereco.com</a>	
ErP label		not applicable	
Max. available duct connections**		4	4
Max. connectable exhaust units (airflow capacity)		2	2
Inlet	mm	ø80	ø80
Outlet	mm	ø100	ø100
Installation		inside the heated volume / in protected non-inhabitable place (attic, etc.) / wall / ceiling / floor	
Filter		■ (removable)	■ (removable)
Cleaning		easily openable cover (no tools needed)	
Removable electrical part		■ (motor change without taking off the fan)	■ (motor change without taking off the fan)
Direct-drive impeller		■	■
Speed	RPM	1395	1395
12 VAC output for 2 boost airflow exhaust units supply		■	■

\*supply voltage not compatible with EU standard  
 \*\*available accessories: ø80, ø100 and ø125 mm

■ standard

Airflow characteristics

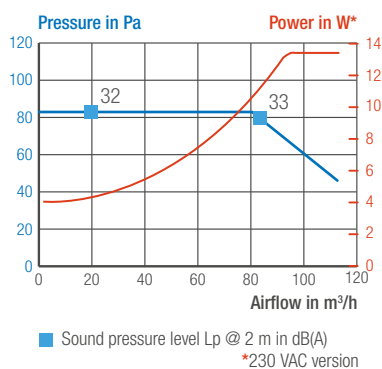

Dimensions in mm

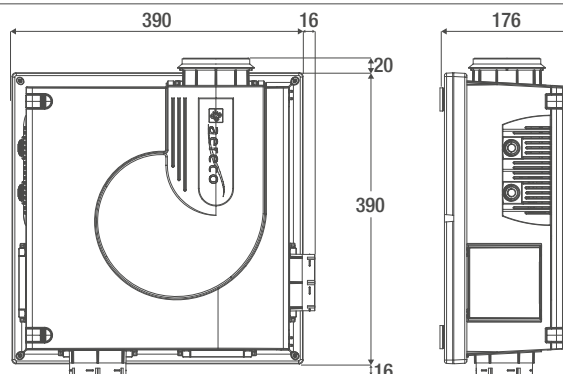



## V4A PREMIUM

Acoustic whole-house fan – 4 rooms



**Silent:** only 33 dB(A)\*.



**Low energy consumption:** less than 13 W\*.



**Constant pressure:** fitted to demand controlled exhaust units.



**Easy to install:** flat and compact, directly installed in living space.

**Outlet 125 mm in diameter.**  
**Inlets 100 or 125 mm.**



**Easy to maintain:** simple yearly cleaning of the removable impeller, accessible without tools.



### Silent operation and efficient ventilation of the whole dwelling

The V4A Premium fan is designed to ventilate a complete dwelling, with up to four exhaust units located in the kitchen, in the toilets, and in the bathrooms. Easily hidden in a wall cupboard or in a false ceiling, the V4A Premium will provide all the comfort and air quality you want. It uses an optimised EC-motor, and the electrical part is removable to facilitate maintenance.

#### An efficient motor

The speed of the V4A's EC-Motor (Electronic Commutation Motor) is controlled by an electronic card. The motor speed, associated with a special wheel, holds the pressure at 100 Pa to keep the airflow proportional to the variable cross-section of the connected demand controlled exhaust units. This keeps power consumption and noise emissions to a minimum.

#### Optimised for silence (1, 2)

The high efficiency EC-Motor is mounted on flexible links and is encased in a double-skin envelope: the V4A is totally optimised to work silently, allowing installation inside the dwelling.

#### User-friendly maintenance

Maintenance is simple because the fan is inside the dwelling: the cover is simply lifted off and the impeller is easy to remove thanks to a patented attachment system. And the electrical part is removable, so the motor can be replaced without removing the fan from its support.

#### 12 VAC output for electrical exhaust units

The V4A fan integrates a 12 VAC transformer to supply up to four electrical exhaust units.

\*@ 40 m<sup>3</sup>/h

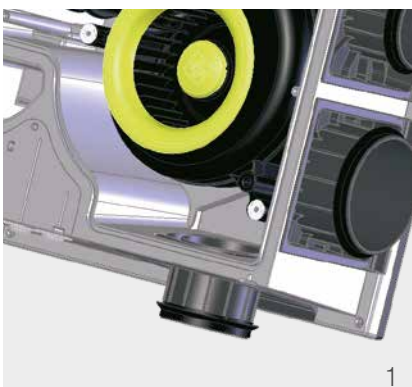

1



2





# V4A PREMIUM

Acoustic whole-house fan – 4 rooms



**Standard code**

**Airflow characteristics**

Max. airflow @ 100 Pa	m³/h
Max. pressure	Pa

**Acoustics**

Sound pressure level Lp (r = 2 m) [airflow in m³/h]	dB(A)
---	-------

**Electrics**

Power supply	100 VAC / 50 Hz
Motor type	EC (Electronic commutation)
Power consumption [airflow in m³/h]	W
Ingress Protection rating	IP30

**Characteristics**

Weight	kg
Colour	grey (light and dark)
Material	PS
Dimensions	mm

**ErP specifications**

SEC, Climat	cold: -53,31 / average: -26,25 / warm: -10,74
ErP Classification from 01/01/2016	B
ErP information	available on <a href="http://www.aereco.com">www.aereco.com</a>
ErP label	available on <a href="http://www.aereco.com">www.aereco.com</a>

**Installation**

Max. available duct connections	4
Max. connectable exhaust units (airflow capacity)	4
Inlet (adaptors not supplied)	mm
Outlet	mm
Installation	inside the heated volume / in protected non-inhabitable place (attic, etc.) / wall / ceiling / floor

**Maintenance (in option)**

Filter	-
Cleaning	easily openable cover (no tools needed) and dismantlable propeller
Removable electrical part	■ (motor change without taking off the fan)

**Operation**

Direct-drive impeller	■
Speed	RPM

**Other functions**

12 VAC output to supply 4 boost airflow exhaust units	■
---	---

**V4A Premium 100V**

**V4A199\***

Max. airflow @ 100 Pa	m³/h	210
Max. pressure	Pa	118
Sound pressure level Lp (r = 2 m) [airflow in m³/h]	dB(A)	33 [40]; 35 [160]
Power supply	100 VAC / 50 Hz	
Motor type	EC (Electronic commutation)	
Power consumption [airflow in m³/h]	W	12.5 [40]; 22 [160]
Ingress Protection rating	IP30	
Weight	kg	6.7
Colour	grey (light and dark)	
Material	PS	
Dimensions	mm	450 x 450 x 219

**V4A Premium 230V**

**V4A336**

Max. airflow @ 100 Pa	m³/h	210
Max. pressure	Pa	118
Sound pressure level Lp (r = 2 m) [airflow in m³/h]	dB(A)	33 [40]; 35 [160]
Power supply	230 VAC / 50 Hz	
Motor type	EC (Electronic commutation)	
Power consumption [airflow in m³/h]	W	12.5 [40]; 22 [160]
Ingress Protection rating	IP30	
Weight	kg	6.7
Colour	grey (light and dark)	
Material	PS	
Dimensions	mm	450 x 450 x 219

\*supply voltage not compatible with EU standard

■ standard

**Airflow characteristics**

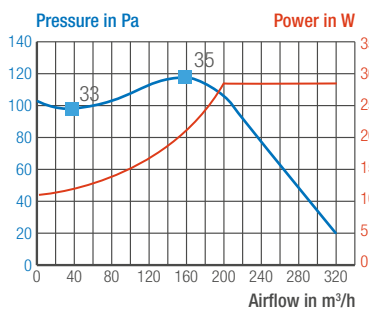

**Dimensions in mm**

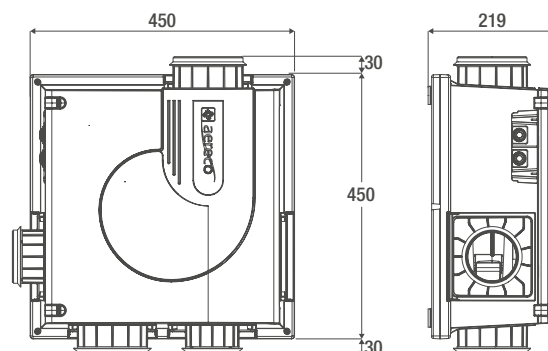

■ Sound pressure level Lp @ 2 m in dB(A)



## V5S

Whole-house fan – 5/6 rooms



Low energy consumption:  
only 10 W\*.



Constant pressure: fitted to  
demand controlled exhaust units.

**Robust design.**

**Reliable and efficient motor,  
made in Germany.**



Easy installation: flat and  
compact, directly installed in  
living space.



### Robust, efficient, and affordable fan

The V5S fan can ventilate a complete dwelling: the 6 available side inlets can be connected to several exhaust units in the wet rooms. With its constant pressure, the fan is well suited to demand controlled exhaust units. The V5S completes the existing line of Aereco fans for individual treatment (the V2A, V4A, and VAM), with comparable features such as a flat design (for installation in a cupboard or in a false ceiling), robust construction, and ease of maintenance thanks to a removable cover. In addition, its large box optimises its aeraulic performance and the energy consumption of the motor. It can be installed in the wet rooms, or in an insulated attic, on the floor, on the ceiling, or on the wall. The V5S exists in two versions: with an EC-motor (V5S “Premium” - pict. 1) or an asynchronous motor (V5S “Reference” - pict. 2 and 3).

### Optimised for demand controlled ventilation

Thanks to the specific design of the impeller and coil set, the pressure is kept constant to allow airflow modulation when connected to demand controlled exhaust units.

### Robust and reliable for long life

The motor, made in Germany by a leading manufacturer, and the robust design (plastic box reinforced by strong ribs) of the V5S guarantee the durability and reliability of the product, which benefits from Aereco's long experience in ventilation.

\*@ 100 m<sup>3</sup>/h (Premium version)



1



2



3



# V5S Whole-house fan – 5/6 rooms



**Standard code**

**Airflow characteristics**

Max. airflow @ 100 Pa	m³/h
Max. pressure	Pa

**Acoustics**

Sound pressure level Lp (r = 2 m) [airflow in m³/h]	dB(A)
---	-------

**Electrics**

Power supply	
Motor type	
Power consumption [airflow in m³/h]	W
Maximum current	A
Thermoswitch	
Ingress Protection rating	

**Characteristics**

Weight	kg
Colour	
Material (main)	
Dimensions	mm

**ErP specifications**

SEC, Climat	
ErP Classification from 01/01/2016	
ErP information	
ErP label	

**Installation**

Max. available duct connections**	
Max. connectable exhaust units (airflow capacity)	
Duct connections	mm
Installation	

**Maintenance**

Filter	
Cleaning	

**Operation**

Direct-drive impeller	
Speed	RPM

**Other functions**

12 VAC output to supply exhaust units	
---------------------------------------	--

**V5S Reference**

**V5S1130**

**V5S Premium**

**V5S1131**

Max. airflow @ 100 Pa	m³/h	280	260
Max. pressure	Pa	140	110
Sound pressure level Lp (r = 2 m) [airflow in m³/h]	dB(A)	41 [150]; 42 [250]	<39
Power supply		230 VAC / 50 Hz	230 VAC / 50 Hz
Motor type		AC (asynchronous single-phase with capacitor)	EC (Electronic Commutation)
Power consumption [airflow in m³/h]	W	26 [100]; 57 [maximum]	10 [100]; 55 [maximum]
Maximum current	A	0.4 A	0.4 A
Thermoswitch		135°C	■
Ingress Protection rating		IP30	IP30
Weight	kg	6.5	7.2
Colour		grey (light and dark)	light brown
Material (main)		high Impact Polystyrene (PS)	polypropylene (PP)
Dimensions	mm	450 x 450 x 210	450 x 450 x 210
SEC, Climat		product not available in EU*	cold: -53,77 / average: -26,71 / warm: -11,21
ErP Classification from 01/01/2016		product not available in EU*	B
ErP information		product not available in EU*	available on www.aereco.com
ErP label		product not available in EU*	available on www.aereco.com
Max. available duct connections**		6	6
Max. connectable exhaust units (airflow capacity)		5 or 6	5 or 6
Duct connections	mm	inlet: Ø100; outlet: Ø125	inlet: Ø100; outlet: Ø125
Installation		inside the heated volume / in protected non-inhabitable place (attic, etc.) / wall / ceiling / floor	
Filter		-	-
Cleaning		openable cover (4 screws)	openable cover (4 screws)
Direct-drive impeller		■	■
Speed	RPM	1450 – 1350 RPM	1170 - 1270 RPM
12 VAC output to supply exhaust units		-	-

\*not fully compliant with ErP

\*\*available accessories: ø80, ø100 and ø125 mm

■ standard

**Airflow characteristics**

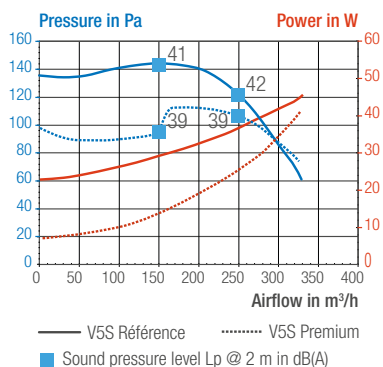

**Dimensions in mm**

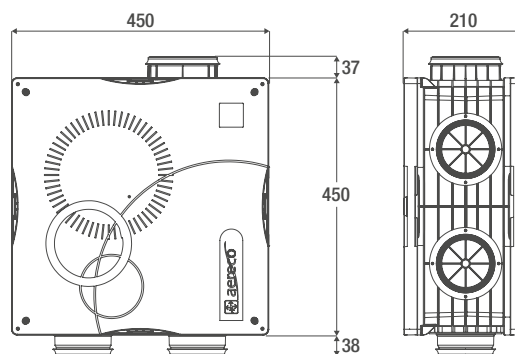



## VAM

Acoustic whole-house fan – 6 rooms



**Silent:** only 29 dB (A)\*.



**Low energy consumption:** only 23 W\*.



**Constant pressure:** fitted to demand controlled exhaust units.



**Easy to install:** easy to handle and can be directly installed in living space (in a wall cupboard, corridor, etc.).

**Choice of 3 settings at the time of installation:** 80, 100 and 120 Pa.

**Outlet 125 mm in diameter**  
**Inlets 100 or 125 mm.**



### High capacity and low consumption

Thanks to its slim styling and silent running, the VAM fan is ideal for installation in living spaces. With its powerful AC motor and its optimised design, the VAM can be connected to up to six exhaust units in the same dwelling. Its airflow characteristics (constant-pressure curve) are well suited to operation with demand controlled exhaust units.

### Intelligent motor

The VAM is driven by a single-phase asynchronous motor the speed of which is held constant by a tachometer and an electronic board, whatever the airflow required by the exhaust units\*. The power is adjusted and optimised to limit noise and energy consumption.

### 3 pressures available

The VAM provides a choice of three pressure levels at the time of installation: 80, 100, or 120 Pa. This feature can be used to satisfy specific regulations or to compensate for complex ductwork.

### Installation close to the occupant

Because the VAM is silent (acoustic foam) and compact, it is easy to install directly in the living space of the dwelling, in a wall cupboard, a loft space, etc. Maintenance is facilitated by its location within the dwelling.

\*@ 100 m<sup>3</sup>/h





# VAM Acoustic whole-house fan – 6 rooms



**Standard code**

**Airflow characteristics**

Max. airflow @ 100 Pa	m³/h	250
Max. pressure	Pa	130
Available pressure settings	Pa	80 - 100 - 120

**Acoustics**

Sound pressure level Lp (r = 2 m) [airflow in m³/h]	dB(A)	29 [100] ; 33 [200]
---	-------	---------------------

**Electrics**

Power supply		230 VAC / 50 Hz - 230 VAC / 60 Hz	100 VAC / 50 Hz
Motor type		asynchronous single-phase	
Power consumption [airflow in m³/h]	W	23 [100] ; 44 [200]	
IP degrees of protection		IP30	

**Characteristics**

Weight	kg	18
Colour		metal
Material (main)		galvanised steel
Dimensions	mm	480 x 480 x 240

**Specifications ErP**

SEC, Climat		Cold: -53,24 / Average: -26,18 / Warm: -10,67
ErP classification from 01/01/2016*		B
ErP information		<a href="http://www.aereco.com/product/vam/">http://www.aereco.com/product/vam/</a>
ErP Label		<a href="http://www.aereco.com/product/vam/">http://www.aereco.com/product/vam/</a>

**Installation**

Max. available duct connections		7
Max. connectable exhaust units (airflow capacity)		6
Inlet**	mm	ø125
Outlet	mm	ø125

Installation inside the heated volume / in protected non-inhabitable place (attic, etc.) / wall / ceiling / floor

**Maintenance**

Filter		-
Cleaning		easy-to-open cover (4 screws)

**Operation**

Direct-drive impeller		■
Max. speed	RPM	1 100

\*regulation based on at least two demand controlled exhaust units  
 \*\*available accessories: ø80, ø100 and ø125 mm

■ standard

**Airflow characteristics**

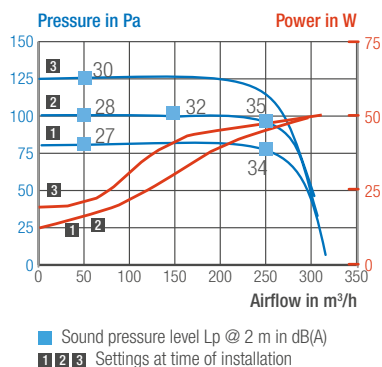

**Dimensions in mm**

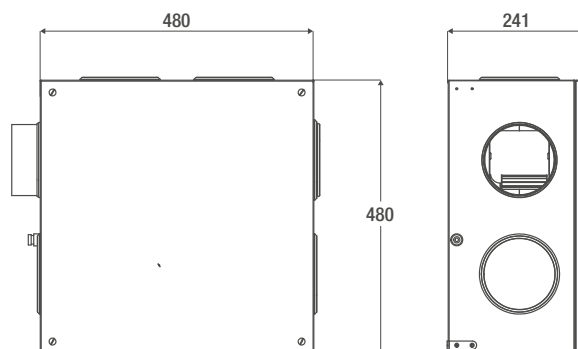



## VTZ

Collective fans for outdoor installation



**Low energy consumption:**  
Electronic Commutation motor associated with an automatic pressure control device.

**Solidity and reliability:** metal design, made in Germany.



**DCV compatible:** integrated automatic pressure control device, optimizing the DCV performance.



**Silent:** acoustic foam on the entire envelope and sound trap available on request, optional.



**Easy to install:** many available adaptation parts, possibility of custom-built construction.



**Easy to maintain (1):** easy cleaning of blades after swinging the fan.



### Solidity and performance for collective outdoor installations

The VTZ fans range offers several models with capacities going from 345 m<sup>3</sup>/h up to 6800 m<sup>3</sup>/h for the equipment of collective dwellings, offices, schools or other buildings. The VTZ fans are designed for an outdoor installation, in terrace or on a pitched roof. Many connecting parts are available to adapt to different encountered cases. The VTZ fans are characterized by their solidity and by an excellent energy efficiency, thanks to the use of high-performance electronic commutation motors and to an integrated pressure control device.

### Electronic commutation motor for minimal consumption

The electronic commutation motor of the VTZ roof exhaust fan offers an optimum consumption all the time. Associated to the pressure control device, it automatically adjusts the consumed power to the requested airflow, while maintaining a constant pressure. The motor integrates an electric cut of switch in case of high temperature and an output which can be used to diagnose a possible default.

### A wide range of adapters for all cases (2)

Aereco offers many adaptation parts made in aluminium or galvanised steel for pitched roofs and for the variable geometries of ducts. Specific parts can also be made custom-built on the basis of plans (contact us).

### Pressure control device (3)

A system of pressure control is integrated in the roof exhaust fan, allowing to define easily the pressure at working. Pressure measured by the integrated pressure gauge is displayed on digital screen. It is automatically regulated, optimizing the system working with demand controlled exhaust units.



1

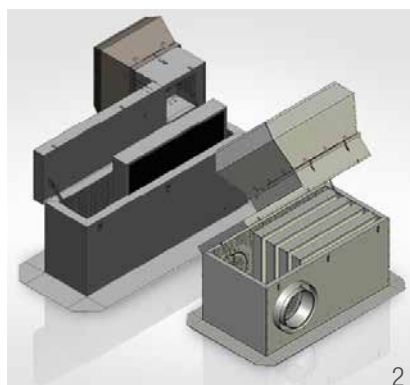

2



3



# VTZ

Collective fans for outdoor installation



	VTZ 0.5	VTZ 0	VTZ 1	VTZ 2	VTZ 3	VTZ 4	VTZ 6	
	VTZ1435	VTZ1075	VTZ1076	VTZ1077	VTZ1078	VTZ1145	VTZ1125	
<b>Standard code</b>								
<b>Airflow characteristics</b>								
Max. possible airflow @ 130 Pa	m³/h	345	600	850	1600	2300	4500	6800
Max. pressure	Pa	180	300	300	300	300	300	300
Pressure control device		■	■	■	■	■	■	■
<b>Acoustics</b>								
Max. sound power level Lw	dB(A)	62	75	72	67	78	75	71
Max. sound pressure level Lp @ 3 m	dB(A)	43	55	52	50	60	60	58
<b>Electrics</b>								
Power supply		230 VAC / 50 Hz	230 VAC / 50 Hz	230 VAC / 50 Hz	230 VAC / 50 Hz	230 VAC / 50 Hz	230 VAC / 50 Hz	230 VAC / 50 Hz
Motor type		EC	EC	EC	EC	EC	EC	EC
Max. power consumption	W	40	87	168	157	465	520	750
IP degrees of protection (motor)		IP 54	IP 54	IP 54	IP 54	IP 54	IP 54	IP 54
<b>Characteristics</b>								
Weight	kg	9	10	12	21	23	48	57
Colour		metal	metal	metal	metal	metal	metal	metal
Material (main)		galvanised steel	galvanised steel	galvanised steel	galvanised steel	galvanised steel	galvanised steel	galvanised steel
Dimensions (A - B - H)	mm	445 - 340 - 290	445 - 340 - 290	547 - 440 - 340	720 - 600 - 400	720 - 600 - 400	955 - 707 - 577	955 - 707 - 577
<b>ErP specification</b>								
ErP information	available on <a href="http://www.aereco.com">www.aereco.com</a>							
SFPint	not required*							
<b>Installation</b>								
Duct connection	mm	336 x 336	336 x 336	436 x 436	595 x 595	595 x 595	704 x 704	704 x 704
Terrace installation		■	■	■	■	■	■	■
Roof installation		■	■	■	■	■	■	■
Attic installation		-	-	-	-	-	-	-
<b>Maintenance</b>								
Proximity switch	rocker switch		■	■	■	■	■	■
Cleaning	swings open for access to impeller and ducts							
<b>Operation</b>								
Direct-drive impeller		■	■	■	■	■	■	■
Max. speed	RPM	2490	3760	3490	1600	2195	1735	1090

\*for unidirectional NRVUs not intended to be used with a filter, SFPint calculation is not applicable

■ standard

Dimensions in mm

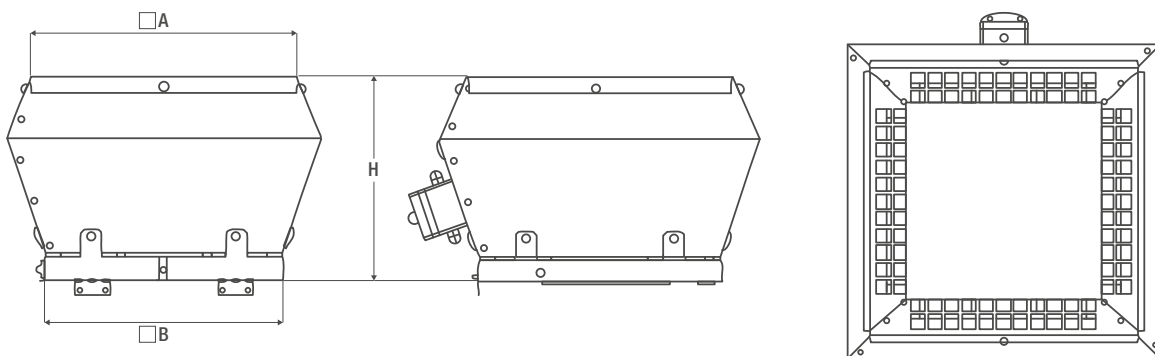



## VCZ

Collective fans for attic or outdoor installation



**Low energy consumption:** Electronic Commutation motor associated with an automatic pressure control device.

**Solidity and reliability:** metal design, made in Germany.



**DCV compatible:** integrated automatic pressure control device, optimizing the DCV performance.



**Silent:** acoustic foam on the entire envelope and sound trap available on request, optional.



**Easy to install:** many available adaptation parts, possibility of custom-built construction.



**Easy to maintain:** motor easily accessible by a trapdoor to clean the blades.



### High-quality collective fans for attic or outdoor installation

The VCZ attic exhaust fans offer several models with capacities from 530 m<sup>3</sup>/h up to 3500 m<sup>3</sup>/h for the equipment of collective dwellings, offices, schools or other types of buildings. They are designed for an installation in attics, on the floor, on the wall or fixed to a beam. The VCZ attic exhaust fans are characterized by their solidity and by an excellent energy efficiency, thanks to the use of high-performance electronic commutation motors and to an integrated pressure control device.

#### An easier maintenance (1)

The VCZ attic exhaust fans are equipped with a trapdoor allowing the direct access to the motor for the propeller cleaning. The latches can be padlocked.

#### **NEW** Specific versions for outdoor installations (2)

The VCZ fan range offers versions for outdoor installations including a rain protection cover as presented on the picture.

#### Pressure control device (3)

A system of pressure control is integrated in the fan, allowing to define easily the pressure at working. Pressure measured by the integrated pressure gauge is displayed on digital screen. It is automatically regulated, optimizing the system working with demand controlled exhaust units.



1



2



3



# VCZ

Collective fans for attics or outdoor installation



		VCZ 0	VCZ 1	VCZ 2	VCZ 3	VCZ 4
<b>Standard code</b>		VCZ1084	VCZ1085	VCZ1086	VCZ1087	VCZ1144
<b>Outdoor version code</b>		VCZ1204	VCZ1205	VCZ1206	VCZ1207	VCZ1208
<b>Airflow characteristics</b>						
Max. possible airflow @ 130 Pa	m³/h	530	820	1500	2100	3500
Max. pressure	Pa	300	300	300	300	300
Pressure control device		■	■	■	■	■
<b>Acoustics</b>						
Max. sound power level Lw Pressure side	dB(A)	79	68	78	66	71
Max. sound power level Lw Suction side	dB(A)	75	64	79	75	73
<b>Electrics</b>						
Power supply		230 VAC / 50 Hz	230 VAC / 50 Hz	230 VAC / 50 Hz	230 VAC / 50 Hz	230 VAC / 50 Hz
Motor type		EC	EC	EC	EC	EC
Max. power	W	87	168	157	445	510
IP degrees of protection (motor)		IP54	IP54	IP54	IP54	IP54
<b>Characteristics</b>						
Weight	kg	22	24	32	37	64
Colour		metal	metal	metal	metal	metal
Material (main)		galvanised steel	galvanised steel	galvanised steel	galvanised steel	galvanised steel
Dimensions H - L		350 - 600	400 - 600	550 - 600	650 - 600	740 - 800
B1 - B2	mm	455 - 555	455 - 555	545 - 645	545 - 645	745 - 845
C1 - C2 - C3		60,5 - 160,5 - 260,5	60,5 - 185,5 - 310,5	83 - 260,5 - 438	110,5 - 310,5 - 510,5	122,5 - 372,5 - 622,5
<b>ErP specification</b>						
ErP information		available on <a href="http://www.aereco.com">www.aereco.com</a>				
SFPint		not required*				
<b>Installation</b>						
Duct connection	mm	ø200	ø250	ø355	ø400	ø500
Position		all positions possible (horizontal, vertical, cover up and down)				
Outdoor installation		□ (VCZ1204)	□ (VCZ1205)	□ (VCZ1206)	□ (VCZ1207)	□ (VCZ1208)
Attic installation (protected)		■	■	■	■	■
<b>Maintenance</b>						
Proximity switch		■	■	■	■	■
Cleaning		cover opens for access to impeller				
<b>Operation</b>						
Direct-drive impeller		■	■	■	■	■
Max. speed	RPM	3500	3440	1600	2190	1760

\*for unidirectional NRVUs not intended to be used with a filter, SFPint calculation is not applicable

■ standard | □ optional

Dimensions in mm

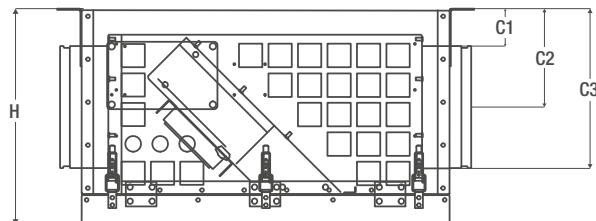
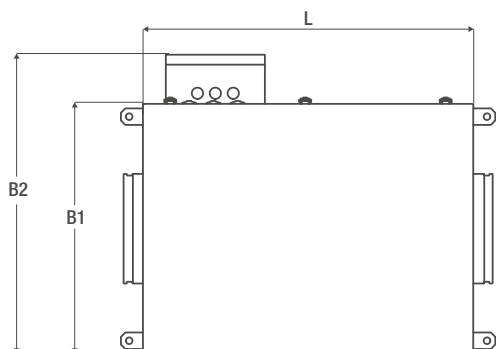



# VTZ

Collective fans for outdoor installation

The following charts describe the fan alone without adapter

VTZ0.5

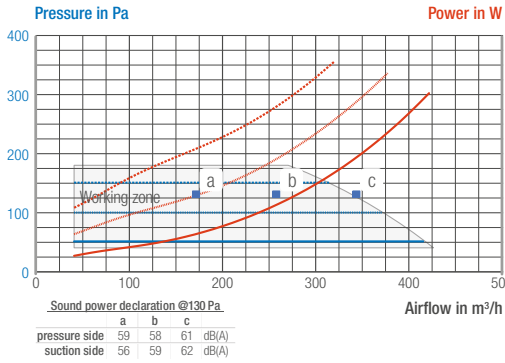

VTZ0

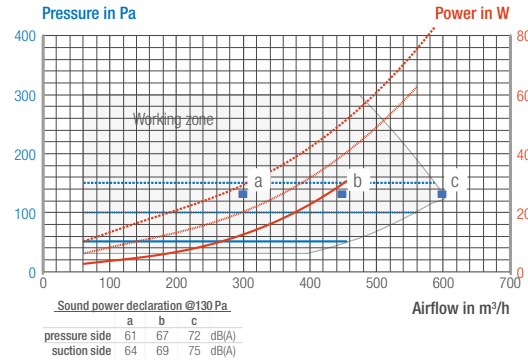

VTZ1

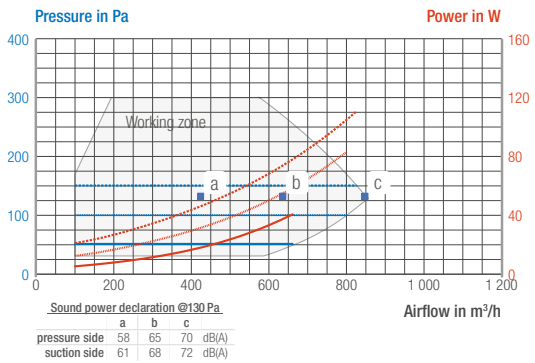

VTZ2

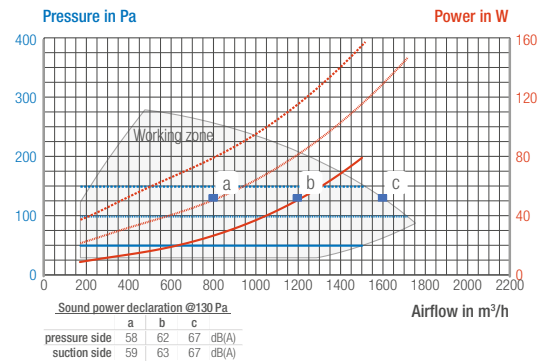

VTZ3

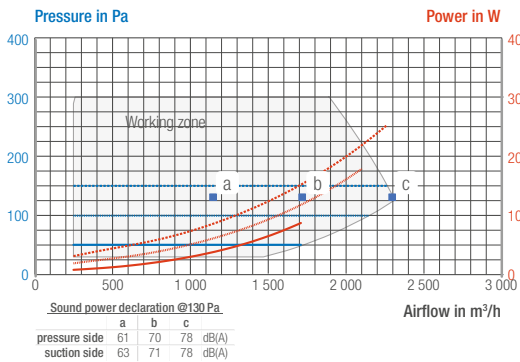

VTZ4

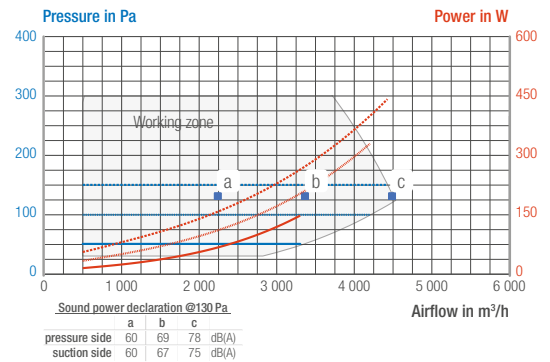

VTZ6

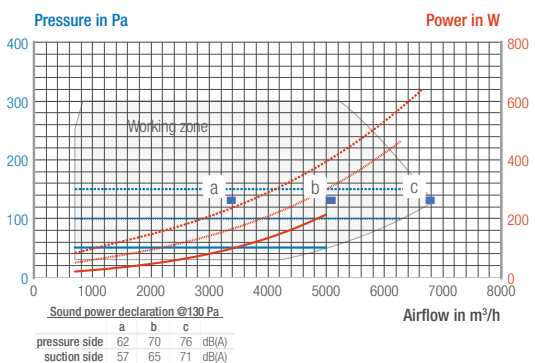



# VCZ

Collective fans for attics or outdoor installation

## VCZ0

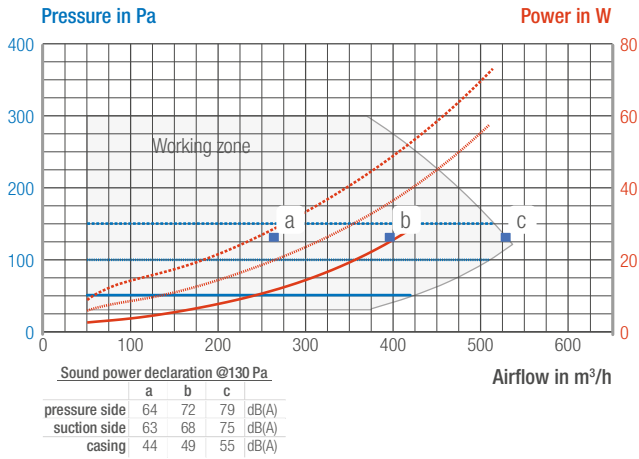

## VCZ1

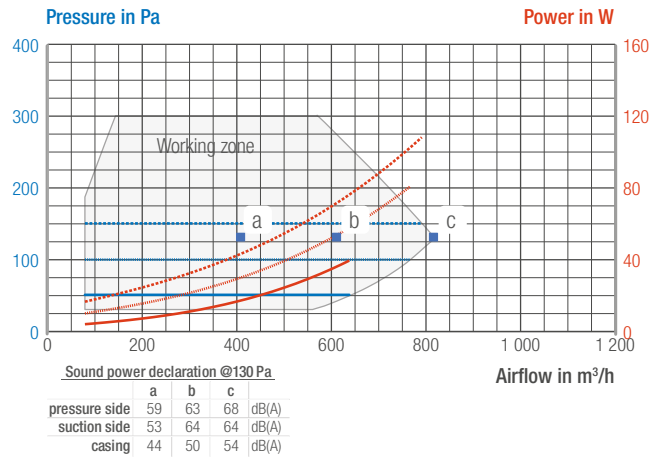

## VCZ2

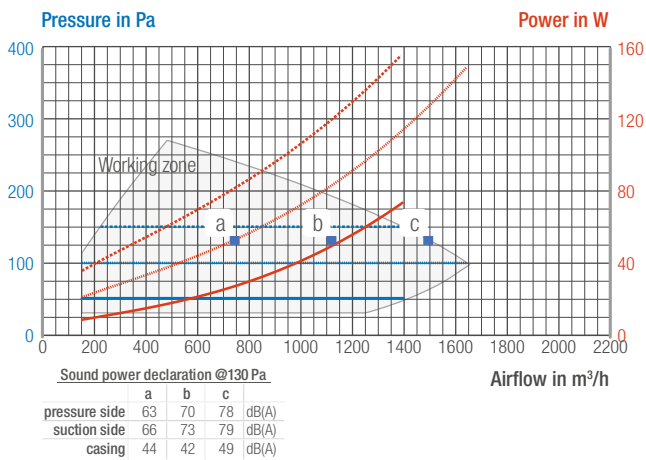

## VCZ3

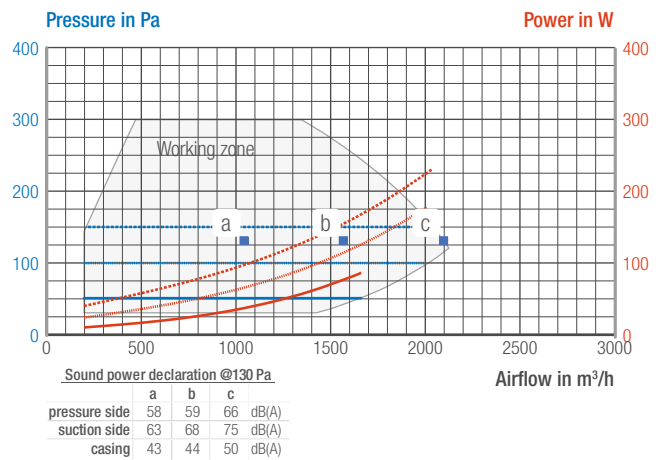

## VCZ4

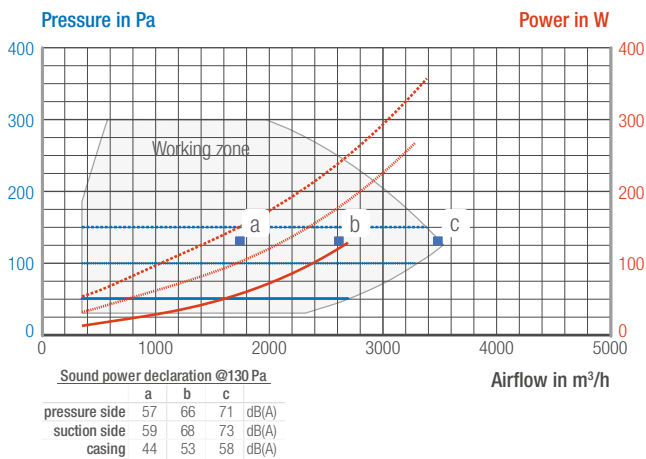

## Keys

- example :
- '50 Pa' setting      — '100 Pa' setting      - - - '150 Pa' setting
  - the limit of the working zone determines the maximum airflow / pressure available at the fan
  - sound power level Lw in dB(A)



## AWN SYSTEM AWN DV

Exhaust fan with heat recovery module  
Outdoor terrace installation



Recovery of the exhaust air energy for heating or water heating through connection to heat pump.



Low energy consumption:  
EC motor associated with an automatic pressure control device.

High energy performance:  
equivalent to A+ class (ErP).



DCV compatible: integrated automatic pressure control device, optimizing the DCV performance.



Easy to install: many available adaptation parts, possibility of custom-built construction.

Terrace installation.



Silent: acoustic foam on the entire envelope and sound trap available on request, optional.



Easy to maintain: motor easily accessible by a trapdoor to clean the blades.

### Demand controlled ventilation, even more energy efficient

The AWN range enhances again the energy performance of the root Aereco demand controlled ventilation system: by adapting the airflows according to the needs in the dwelling, the Aereco DCV system already reduces consequently the heat demand. Through recovering the heat air energy at the level of the exhaust fan, the AWN drastically reduces the energy load for the air renewal. The AWN is connected to a heat pump that can be used for water heating or air heating. The AWN range offers two types of calorigen fluid: water + glycol or refrigerant.

#### Decreasing the energy load of the heating system

Through this system, an important part of the energy induced by the ventilation can be recovered and then be reused to decrease the energy demand of the energy generating system. In the presence of a heat pump for heat generation, this energy can be directly integrated into the heat source circuit (brine or air). In the case of other heat generators, this energy quantity can be brought from the exhaust air to a temperature level (max. 50°C) by means of an autonomous heat pump. Thus, for example, the preheating of the hot water is possible or is provided in a buffer store for the heating and / or hot water. In the case of combined use of the ventilation and heat pump technology, a heat exchanger is installed in front of the exhaust fan. The remaining usable energy is extracted from the exhaust air. Intelligent control optimizes the supply and demand of energy from exhaust air and outside air.

#### Pressure control device

A pressure control system is integrated in the fan, allowing to define easily the working pressure. Pressure measured by the pressure gauge is displayed on digital screen. It is automatically regulated, optimizing the system working with demand controlled exhaust units.

#### Easy maintenance

The AWN DV exhaust fans are equipped with a trapdoor allowing the direct access to the motor for the propeller cleaning.





# AWN DV Exhaust fan with heat recovery module

		AWN DV-A40 h G	AWN DV-A50 h G	AWN DV-A70 h G
Outdoor installation configuration		■	■	■
Standard configuration		connection side left side (seen in air direction)		
<b>Energetic data</b>				
Corresponding estimated living space	m <sup>2</sup>	1 760	2 640	3 840
Maximum heat extraction per year	MWh	73	120	159
Heat supply degree (brine 7°C/0°C)	%	78 / 115	86 / 126	83 / 122
Maximum heat supply of heat pump	kW	11,6	19,3	25,5
<b>Features</b>				
Dimensions (W x H x L)	mm	900 x 1 155 x 1 490	1 460 x 1 425 x 1 600	1 460 x 1 625 x 1 600
Sound pressure level, housing radiation Lwag** /suction side**	dB	72 / 55	69 / 62	71 / 65
Weight	kg	143	175	304
<b>Heat exchanger air/water/glycol transfer to exchanger medium</b>				
Heat recovery	kW	5,1	10,5	14,7
Exhaust air inlet/outlet temperature	°C	20 / 12,3	20 / 10,4	20 / 10,6
Water glycol (35%) fluid	m <sup>3</sup> /h	0,87	1,9	2,8
Water glycol inlet temperature/ outlet temperature	°C	7 / 13,2	7 / 12,3	7 / 12,3
Filter protection G4 (with filter monitoring)		■	■	■
Heat exchanger flow and return		Cu ¾" thread	Cu 1" external thread	Cu 1" external thread
Glycol pressure sensor / glycol dyke inclusive accessories		■	■	■
Condensate trough inclusive accessories		■	■	■
Condensate tube diameter	mm	ø 20	ø 20	ø 20
<b>Fan motors</b>				
Fan type		DV-A40	DV-A50	DV-A70
Nominal airflow @ 130 Pa**	m <sup>3</sup> /h	2 200	3 300	4 800
EC technology		■	■	■
Connection facilities (exhaust air pipes)		lateral (x2), front-end (x1)	lateral (x2), front-end (x1)	lateral (x2), front-end (x1)
Exhaust air pipe connector diameter (DN)	mm	355	400	400
SFP* @ 130 Pa** / SFP* with 75% @ 130 Pa**	W/m <sup>3</sup> h	0,19 / 0,14	0,159 / 0,12	0,124 / 0,099
Power consumption at 75% (specification)	W	226	230	355
Repair switch		■	■	■
Connection voltage		230 V / 50 Hz	230 V / 50 Hz	230 V / 50 Hz
Rated current @ 130 Pa**	V	1,8	1,66	2,64
Nominal power @ 130 Pa**	W	410	381	597
Maximum power consumption (motor start)	W	450	530	735
Protection type	IP	54	54	54
Maximum air temperature	°C	40	40	40
Error message		■	■	■
Mains connection		to repair switch, otherwise completely hardwired		
Smoke detectors and bypass for free outflow in the event of a fire		□	□	□

\*SFP = volume flow-related ventilation device performance  
 \*\*tested by Institut für Luft und Kältetechnik (ILK) Dresden.

■ standard | □ optional



## AWN SYSTEM AWN RV

Exhaust fan with heat recovery module  
Under roof or outdoor installation



Recovery of the exhaust air energy for heating or water heating through connection to heat pump.



Low energy consumption:  
EC motor associated with an automatic pressure control device.

High energy performance:  
equivalent to A+ class (ErP).



DCV compatible: integrated automatic pressure control device, optimizing the DCV performance.



Easy to install: many available adaptation parts, possibility of custom-built construction.

Under roof or outdoor installation (special version).



Silent: acoustic foam on the entire envelope and sound trap available on request, optional.



Easy to maintain: motor easily accessible by a trapdoor to clean the blades.

### Demand controlled ventilation, even more energy efficient

The AWN range enhances again the energy performance of the roof Aereco demand controlled ventilation system: by adapting the airflows according to the needs in the dwelling, the Aereco DCV system already reduces consequently the heat demand. Through recovering the heat air energy at the level of the exhaust fan, the AWN drastically reduces the energy load for the air renewal. The AWN is connected to a heat pump that can be used for water heating or air heating. The AWN range offers two types of calorigen fluid: water + glycol or refrigerant.

### Decreasing the energy load of the heating system

Through this system, an important part of the energy induced by the ventilation can be recovered and then be reused to decrease the energy demand of the energy generating system. In the presence of a heat pump for heat generation, this energy can be directly integrated into the heat source circuit (brine or air). In the case of other heat generators, this energy quantity can be brought from the exhaust air to a temperature level (max. 50°C) by means of an autonomous heat pump. Thus, for example, the preheating of the hot water is possible or is provided in a buffer store for the heating and / or hot water. In the case of combined use of the ventilation and heat pump technology, a heat exchanger is installed in front of the exhaust fan. The remaining usable energy is extracted from the exhaust air. Intelligent control optimizes the supply and demand of energy from exhaust air and outside air.

### Pressure control device

A pressure control system is integrated in the fan, allowing to define easily the working pressure. Pressure measured by the pressure gauge is displayed on digital screen. It is automatically regulated, optimizing the system working with demand controlled exhaust units.

### Easy maintenance

The AWN RV exhaust fans are equipped with a trapdoor allowing the direct access to the motor for the propeller cleaning.

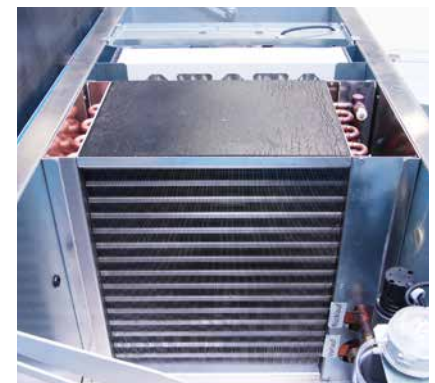



# AWN DV

 Exhaust fan with heat recovery module

## AWN DV-A40 h - Dimensions in mm

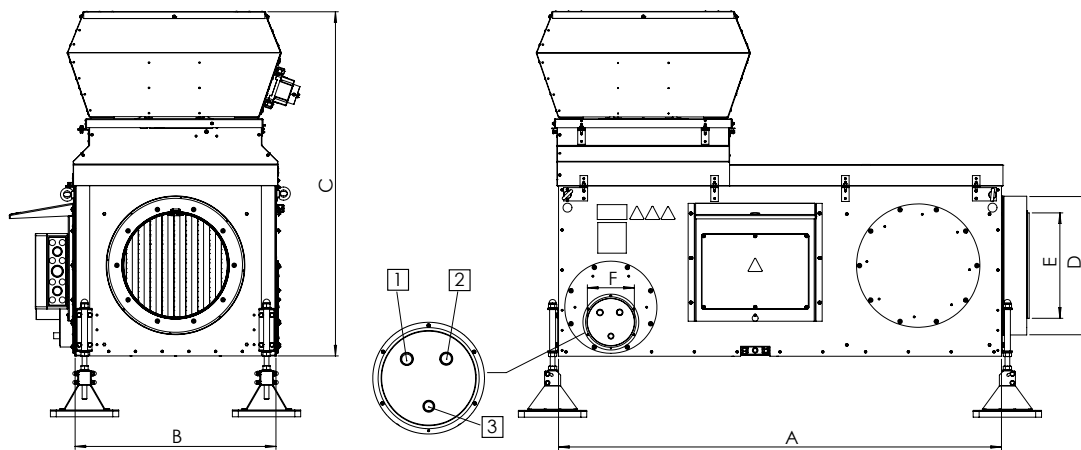

## AWN DV-A50 h / DV-A70 h - Dimensions in mm

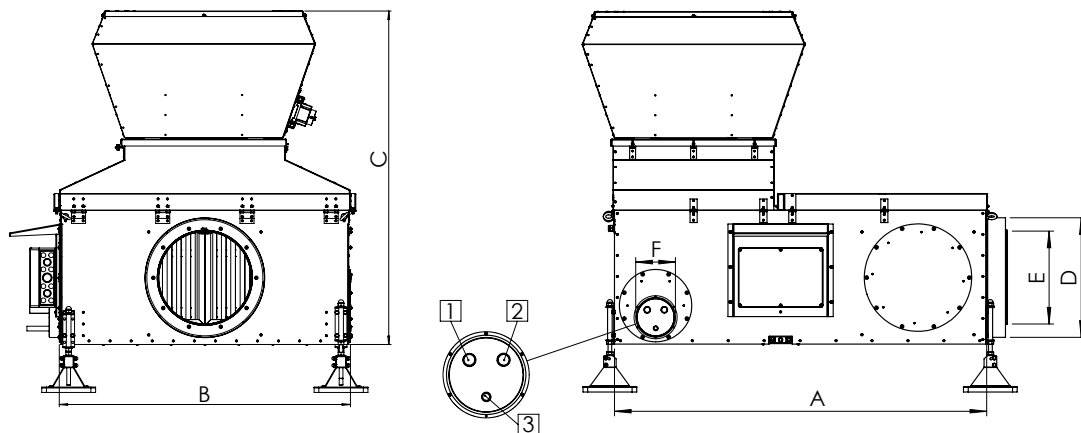

	Overall size	AWN DV-A40 h	AWN DV-A50 h	AWN DV-A70 h
<b>A</b>	Length [mm]	1 490	1 600	1 600
<b>B</b>	Width [mm] / + control unit	680 / 900	1 240 / 1 470	1 240 / 1 470
<b>C</b>	Height [mm]	1 155	1 425	1 625
<b>D</b>	Insulated connection of air channeling connection pipe socket	DN 467	DN 512	DN 512 (2x)
<b>E</b>	Connection spigot	DN 355	DN 400	DN 400 (2x)
<b>F</b>	Insulated connection of tube bundle	DN 160	DN 160	DN 160
<b>1</b>	Heat exchanger – return flow	Copper tube 3/4"	Copper tube 1"	Copper tube 1"
<b>2</b>	Heat exchanger flow	Copper pipe 3/4"	Copper pipe 1"	Copper pipe 1"
<b>3</b>	Condensate drainage	DN 20 plastics	DN 20 plastics	DN 20 plastics

# AWN RV Exhaust fan with heat recovery module

## AWN RV-A40 (OD) h - Dimensions in mm

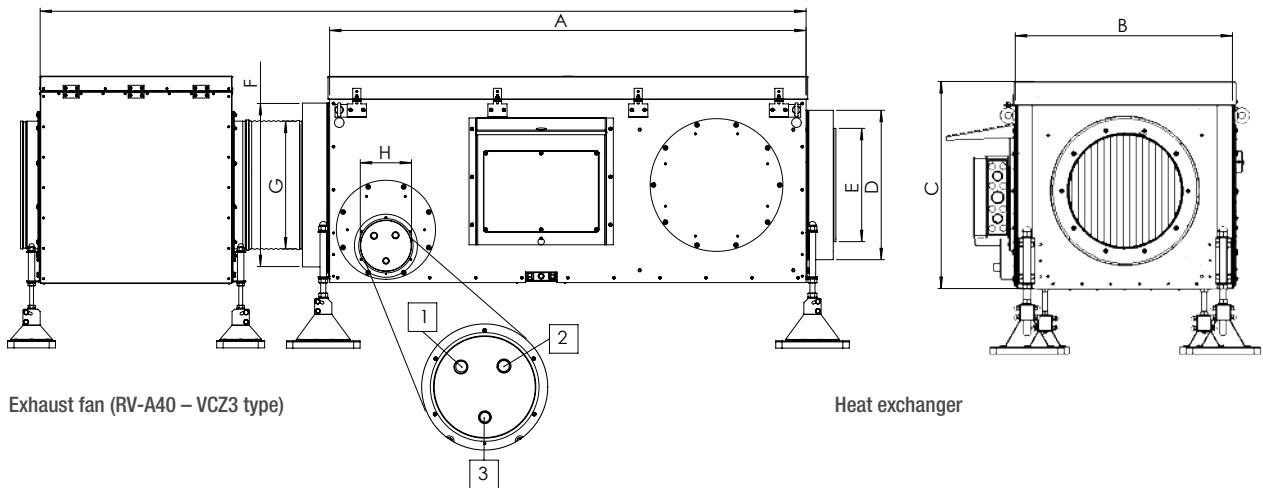

Exhaust fan (RV-A40 – VCZ3 type)

Heat exchanger

## AWN RV-A50 (OD) h - Dimensions in mm

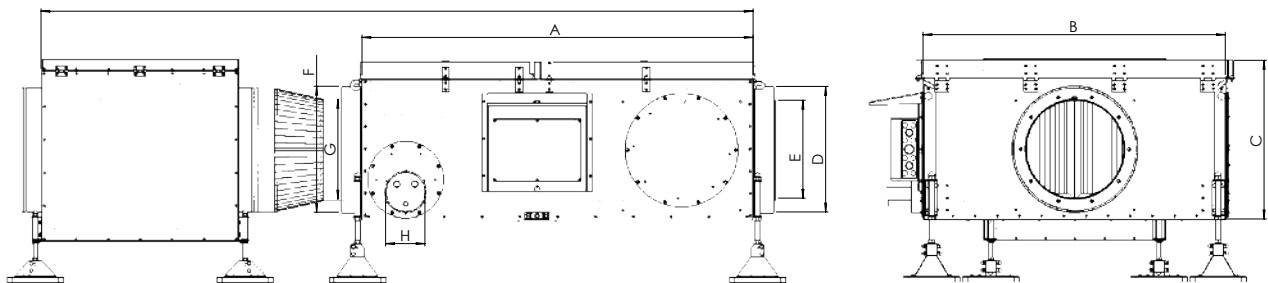

Exhaust fan (RV-A50 – VCZ4 type)

Heat exchanger

Remark: the exhaust fan is included in the AWN. See the datasheet of the fan for its dimensions.

	Overall size	AWN RV-A40 (OD) h	AWN RV-A50 (OD) h
<b>A</b>	Length [mm]	1 490	1 630
<b>B</b>	Width [mm] / + control unit	695 / 864	1 245 / 1 415
<b>C</b>	Height [mm]	643	643
<b>D</b>	Insulated connection of air channeling connection pipe socket	DN 467	DN 512
<b>E</b>	Connection spigot	DN 355	DN 400
<b>F</b>	Insulated connection of fan connection spigot	DN 512	DN 612
<b>G</b>	Fan connection spigot	DN 400	Special type DN 500
<b>H</b>	Insulated connection of tube bundle	DN 160	DN 160
<b>1</b>	Heat exchanger – return flow	Copper tube 3/4"	Copper tube 1"
<b>2</b>	Heat exchanger flow	Copper tube 3/4"	Copper pipe 1"
<b>3</b>	Condensate drainage	DN 20 plastics	DN 20 plastics



# VBP

Assistance fan for hybrid ventilation

**Hybrid working:** does not interfere with natural ventilation when stopped / at very low speed.

**Not critical:** allows natural ventilation if the fan stops.



**Low energy consumption:** only 16 W at 300 m<sup>3</sup>/h.



**Constant pressure:** fitted to demand controlled ventilation.

**Adapts to weather conditions:** management system (MS version) with temperature sensor.



**Easy to install:** on natural ventilation ductwork (renovation or new building).



**Low maintenance:** low air speed = less dust accumulation.



## Optimizing the performance of passive stack ventilation

Installed at the top of a ventilation duct, the VBP hybrid fan guarantees a satisfactory airflow all year long on a former natural ventilation installation. By creating additional pressure when the natural draught is not sufficient, as may sometimes happen in warm and hot weather, the VBP hybrid fan optimises the working of natural ventilation while leaving its dimensions unchanged (ventilation exhaust units and air ducts). Its patented principle is specially designed to allow both mechanical and natural exhaust modes: the exhaust fan can work at very low speed when the stack effect is sufficient without creating any pressure loss. Its motor speeds up when the temperature increases, to compensate for a potential loss of stack effect. With a consumption of only a few Watts per dwelling, the VBP hybrid fan is an excellent alternative to mechanical exhaust ventilation and natural ventilation. Its sizing makes it suitable for apartment blocks up to 7 storeys.

### Unique design for operation in passive stack ventilation (1)

With its unique design, the VBP does not induce any pressure loss when stopped: its central blades are parallel to the airflow, and static paddles located outside the vertical airflow generate the pressure in operation. This allows normal operation of the passive stack ventilation when the fan is off.

### Management system (2)

In the MS version (management system), the VBP is wired to a box which controls the simultaneity of operation and the power of several fans. The device also controls fan speeds according to the outdoor temperature or wind speed (different versions).

### Thermal protection against extreme cold (3)

Available as an accessory, polystyrene thermal insulation protects the VBP motor from freezing in very cold climates.

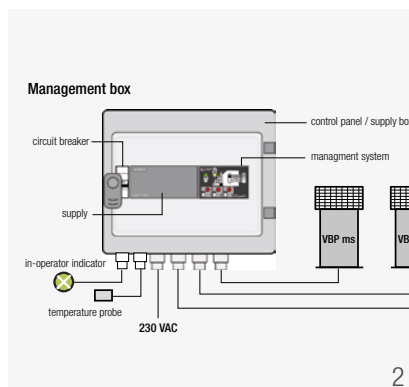
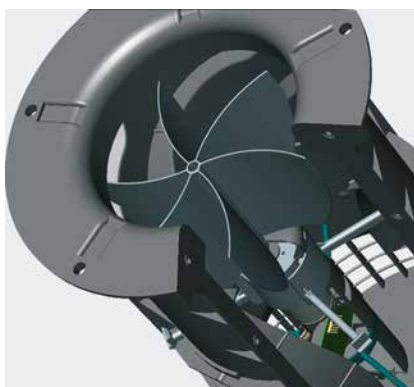



# VBP Assistance fan for hybrid ventilation

		VBP st	VBP ms
		VBP042 / VBP318*	VBP04 / VBP331*
<b>Standard code</b>			
<b>Airflow characteristics</b>			
Max. airflow	m³/h	400	400
Pressure @ 400 m³/h	Pa	17 Pa @ 12 V	14 Pa [1 VBP / 5-7 levels]
<b>Acoustics</b>			
Sound power level Lw @ 9 V (duct)	dB(A)	46	46
<b>Electrics</b>			
Power supply		from 8 VDC to 12 VDC	12 VDC + management system
Max. current	A	1	1
Motor type		EC (Electronic commutation)	EC (Electronic commutation)
Power @ 300 m³/h - 12 V	W	16	16
Ingress Protection rating		IP54	IP54
<b>Characteristics</b>			
Weight	kg	5.5	5.5
Colour		black	black
Material (main)		PAA 66 35% G.F.	PAA 66 35% G.F.
Dimensions	mm	612 x ø350	612 x ø350
<b>Installation</b>			
Max. available duct connections		1	1
Outlet	mm	ø240	ø240
Terrace installation, head of duct	mm	■	■
<b>Operation</b>			
Direct-drive impeller		■	■
Max. speed	RPM	1000	1000
<b>Accessories</b>			
Management box** with temperature sensor for up to 3 fans (ref. AVE197)		-	☒
Management box** with temperature sensor for up to 6 fans (ref. AVE198)		-	☒
Wind gauge + special management box		-	compatible

\*delivered with rain protection (clipped to the top of the VBP fan)

\*\*checks that all VBP fans connected are simultaneously in operation, and manages the power according to the temperature.

■ standard | ☒ mandatory

Dimensions in mm

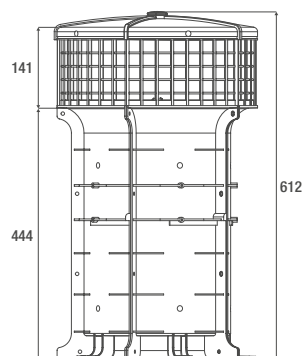
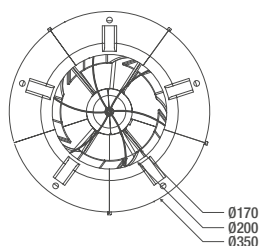



# VBP+

Assistance fan for hybrid ventilation

**Hybrid working:** allows natural ventilation when stopped / at very low speed.

**Not critical:** ensures natural ventilation if the fan stops.



**Low energy consumption:** only 35 W at 800 m<sup>3</sup>/h\*.



**Constant pressure:** adapted to demand controlled ventilation



**Fire safety:** can withstand hot smoke up to 400°C for 30 mn

**Adapts to weather conditions:** management system (ms version) with temperature sensor.



**Renovation or new building,** on natural ventilation ductwork.

**Alarm output** (ms version).



**Low maintenance:** low air speed = lower dusting.

\*@ 20 Pa



## Hybrid ventilation, more energy efficient than ever

The VBP+ hybrid ventilation fan range is the ideal solution for the renovation of buildings equipped with natural or passive stack ventilation ducts, improving the performance of the ventilation through a very low electrical consumption. Its hybrid working, at very low pressure, (natural or mechanical mode) enables to automatically adapt to weather conditions to keep the pressure in the ductwork, all year long. The VBP+ is specially designed for demand controlled ventilation (humidity sensitive, presence detection or other activation modes) thanks to its pressure management. Located on a terrace or on a slope roof, the VBP+ is easily installed on the top of chimney through adaptation parts. Its large free area (equivalent to 8 ducts of ø125 mm) allows to gather several collective or individual ducts without reducing the cross section. Not critical in case of supply default with its patented blades design (no pressure losses when stopped), the VBP+ requires a very light maintenance in comparison with standard mechanical systems, making of it a privileged solution for social housing. Equipped with an EC motor, the VBP+ has a very low energy consumption. The VBP+ exists in two versions, both fire resistant, which enable the VBP+ C4 and the VBP+ R to withstand to hot smoke up to 400°C for 30 minutes.

### Patented smart blades design (1)

The unique smart propeller design of VBP+ prevents from creating pressure loss when stopped: the central blades are parallel to the airflow, the airflow being generated through static peripheral paddles. Thus, the system is not critical in case of supply failure (natural ventilation working mode). The C4 version offers a galvanised steel propeller; the R version is equipped with a plastic one.

### Fire safety (2)

The VBP+ fan range offers a very high level of fire safety: thanks to body and structure in galvanized steel and their patented design, the R version and the C4 version enable to extract smoke up to 400 °C, at their nominal airflow, during 30 minutes. Thanks to the non-combustible matrix made of calcium silicate protecting the motor, the C4 version can still operate to fire smoke up to 400°C, at least during 30 minutes.

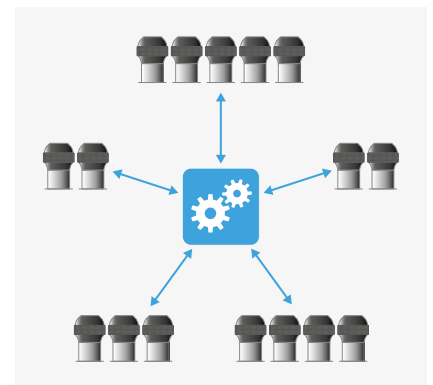
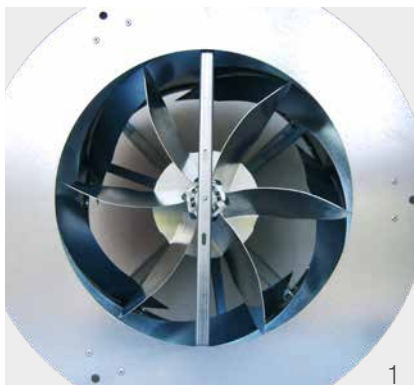



# VBP+ Assistance fan for hybrid ventilation

		VBP+ R	VBP+ C4
<b>ST version code</b>		VB21184	VB21116
<b>MS version code</b>		VB21183	VB21124
<b>Airflow characteristics</b>			
Max. airflow	m³/h	1000	1000
Max. pressure @ Max. airflow	Pa	21 (ST) / 20 (MS)	20
Max. pressure @ 200 m³/h	Pa	39 (ST) / 35 (MS)	35
<b>Acoustics</b>			
Max. sound power level Lw	dB(A)	59	61
Max. sound pressure level Lp @ 4m	dB(A)	36	38
<b>Electrics</b>			
Motor type		EC (Electronic commutation)	EC (Electronic commutation)
Power supply		230 VAC, 50-60 Hz	230 VAC, 50-60 Hz
Max. power	W	41 (ST) / 39 (MS)	42
Ingress Protection rating		IP54	IP54
Control		by built-in potentiometer (ST) or by management system (MS)	by built-in potentiometer (ST) or by management system (MS)
Degree of pollution		1	1
<b>Characteristics</b>			
Weight	kg	17	20
Colours		metal grey / black	metal grey / black
Material (main)		galvanised steel / PE	galvanised steel / PE
External dimensions	mm	904 / ø610	904 / ø610
<b>Fire safety</b>			
Guarantee of extracted nominal airflow*		■	■
Preservation of the motor running*		-	■
<b>Installation</b>			
Number of available draft connections		1	1
Outlet		ø354	ø354
Installation	mm	installation on terrace, head of the air duct / 3 x screws ø8	installation on terrace, head of the air duct / 3 x screws ø8
<b>Operation</b>			
Direct-drive impeller		by motor coupler	by shaft / motor coupler
Max. speed	RPM	650	650

Remark: the indicated pressure is the static pressure.  
\*test conditions = 400°C; 30 minutes

■ standard

Dimensions in mm

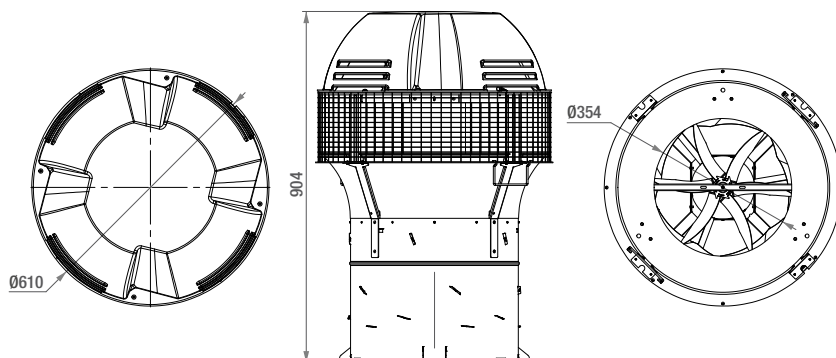



# VBP Assistance fan for hybrid ventilation

Aeraulics and power consumption

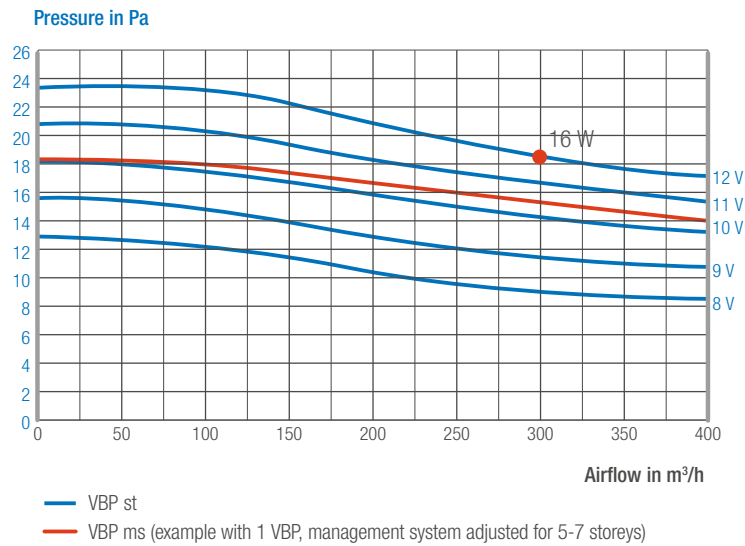

Components of the management system (MS)

## Management box

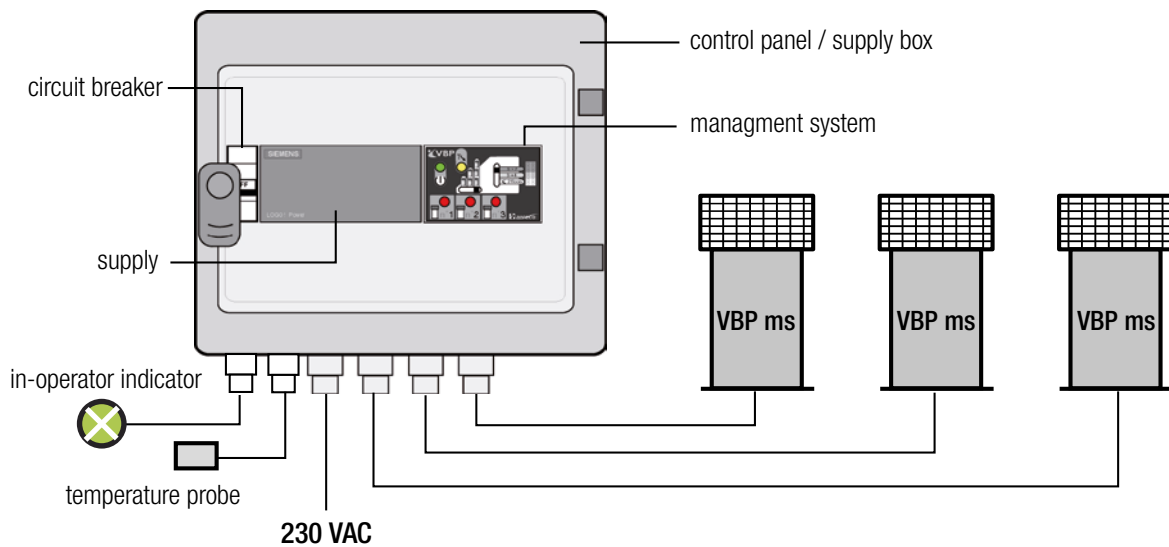



# VBP+ Assistance fan for hybrid ventilation

## Aeraulics and power consumption

Pressure in Pa

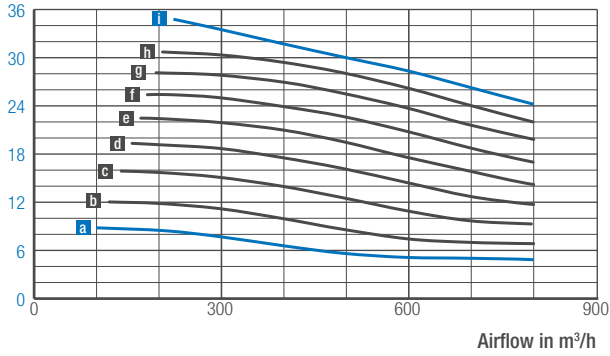

- VBP+ C4 – Minimum and maximum speeds
- VBP+ C4 – Intermediate curves (examples)

Power consumption in W

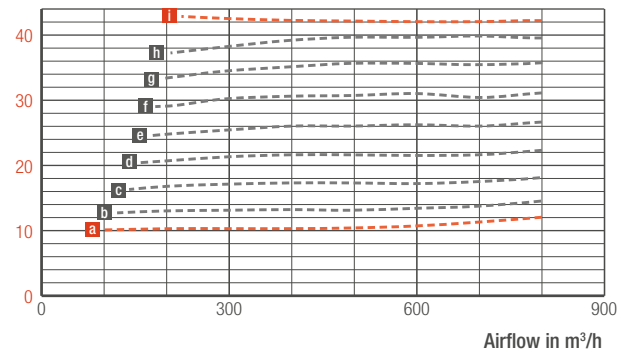

- VBP+ C4 – Minimum and maximum speeds
- VBP+ C4 – Intermediate curves (examples)

Pressure in Pa

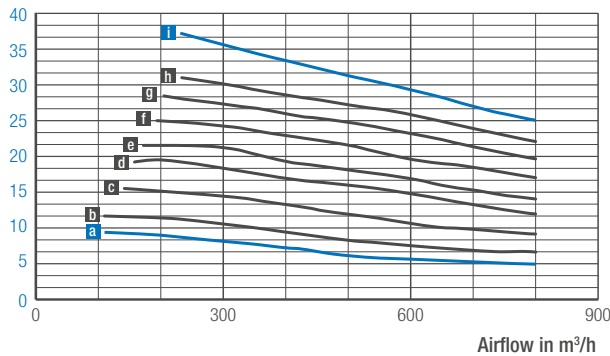

- VBP+ R – Minimum and maximum speeds
- VBP+ R – Intermediate curves (examples)

Power consumption in W

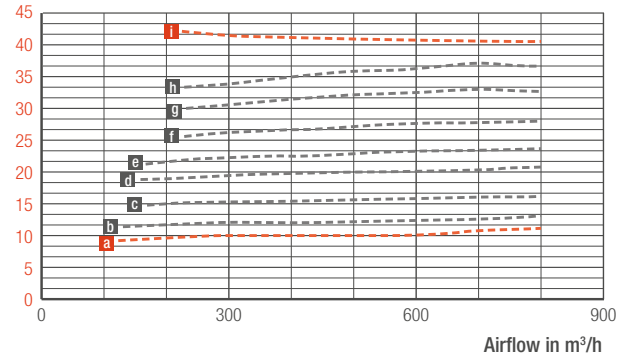

- VBP+ R – Minimum and maximum speeds
- VBP+ R – Intermediate curves (examples)

## Components of the management system (MS)

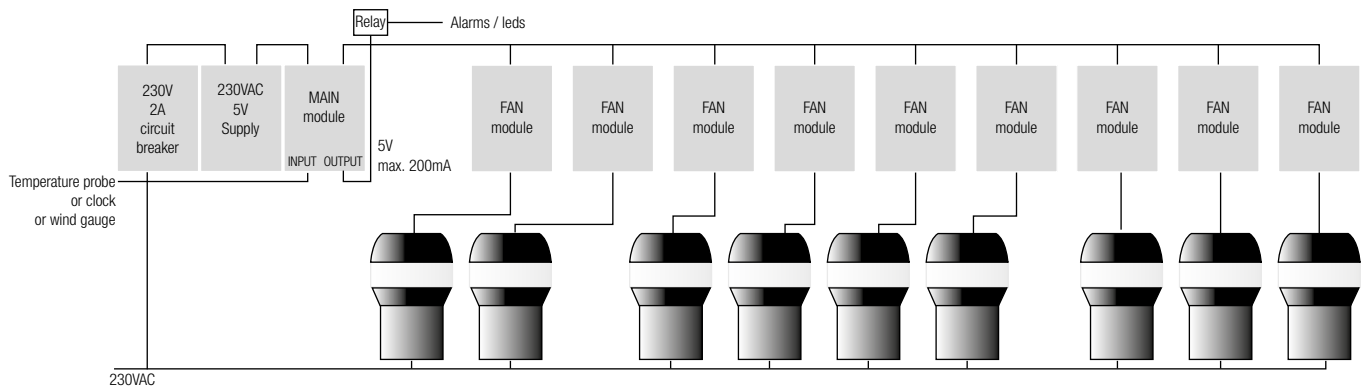



## DX SYSTEM DXR

Heat recovery unit for ceiling installation

**DCV** Constant pressure fitted to demand controlled exhaust units.



**Dynamix® Technology\***: ensures a silent system and optimal indoor air quality\*.



Very low energy consumption by combining demand control of airflows and heat recovery.



Easy installation in ceiling spaces thanks to its small thickness (only 26 cm).



Easy maintenance of the filters through compact bottom trapdoors.

High-quality manufacture with main parts, made of metal.

\*specific to Excellence version



### Flat heat recovery with demand control for ceiling installation

Designed for ceiling installation within the heated space, the DXR provides a truly elegant solution for multi-apartments buildings, where available space for systems is often limited, particularly in renovation projects. Its very low thickness (26 cm) and its reduced width (65 cm) allow easy installation in ceiling spaces (for example in a corridor false ceiling). The DXR unit is compatible with two demand control strategies used in the DX System “Premium” and “Excellence”.

#### Indoor Air Quality at its best (1)

The DXR enhances indoor comfort by providing healthy air, at a milder temperature, preheated by the integrated heat exchanger. To feel good at home, the Dynamix® Technology, available on “Excellence” version, adapts, at any time, both supply and exhaust airflows to the occupants needs in every room through accurate sensors (CO<sub>2</sub> or presence). The Dynamix® Technology is a smart demand control strategy specific to the DX System which follows two main purposes: to reduce inherent noise from the heat recovery system while guaranteeing the best Indoor Air Quality.

#### Low maintenance (2)

By reducing the average airflows with an equivalent indoor air quality and thanks to a large surface of filtration, filter durability is doubled compared to traditional heat recovery systems.

#### Low energy consumption (3)

In addition to significant energy savings on heat losses thanks to the Dynamix® Technology, the DXR limits primary energy consumption by reducing fan power. Combining a smart and accurate demand control strategy and high quality fans, the DXR offers a very good energy performance, up to 50% reduction of electrical consumption in comparison with standard heat recovery units.





# DXR Heat recovery unit for ceiling installation



<b>Standard code</b>	
<b>Ecodesign</b>	
Label (EU Ecodesign Directive)	
<b>Airflow characteristics</b>	
Max. airflow	m³/h
Other nominal airflows	m³/h
Pressure at exhaust	Pa
Airflow compensation (filter clogging)	
Airflow balance (supply and exhaust)	
<b>Acoustics</b>	
Sound power level Lw @ 161 m³/h, 50 Pa	dB(A)
Sound power level Lwa [ a / b / c / d ]	dB
<b>Electrics</b>	
Power supply	
Motor type	
Power consumption @ 161 m³/h @50 Pa	W
Power consumption @ 230 m³/h @50 Pa	W
Sensors connections	
<b>Demand control</b>	
Compatible versions of DX System	
Min - Max Number of sensors for modulation at supply	
Min - Max Number of sensors for modulation at exhaust	
Sensors type at supply	
Exhaust units type	
<b>Characteristics</b>	
Exchanger	
Filters	
Weight	kg
Colour	
Material (main)	
Dimensions	mm
Certifications	
<b>Installation</b>	
Max. number of main rooms	
Max. number of technical rooms	
Connections	
Installation	
<b>Other functions</b>	
Interface	
Bypass	
Preheating (optional)	
Condensation management	
<b>Temperature of use</b>	
Installation room	
Incoming outdoor fresh air or Extract	

<b>DXR 230</b>	
<b>DXR1225</b>	
A+ (with 2 IAQ sensors)	
230	
80 / 140 / 200	
60	
automatic	
automatic	
40	
40 / 43 / 46 / 49	
230 VAC, 50 Hz	
EC (x2)	
34,2	
91,0	
RJ12	
Premium / Excellence	
1 - 5	
1 - 5	
presence / CO <sub>2</sub>	
humidity / presence / switch / CO <sub>2</sub> / VOC	
aluminium / counter flow type / 82% efficiency	
on supply air: 1 x F7 / on exhaust air: 1 x G4	
46	
white	
galvanised steel with phonic and thermal insulation	
with duct connectors: 260 x 650 x 1200 / without duct connectors: 260 x 650 x 1160	
CE	
6	
5	
2 x (2 x ø160 mm)	
horizontal only, to the ceiling / 4 points of attachment	
2,8" colour touch screen interface. Wired to DXR	
controlled by outdoor temperature / also used for free cooling	
with resistance in fresh air ductwork from outside	
exhaust through lateral tube / optional condensate pump	
frost free: +5°C < T° < +50°C	
-5°C < T° < +50°C without preheating / -26°C < T° < +50°C with preheating	

for other components: see designation on page 30

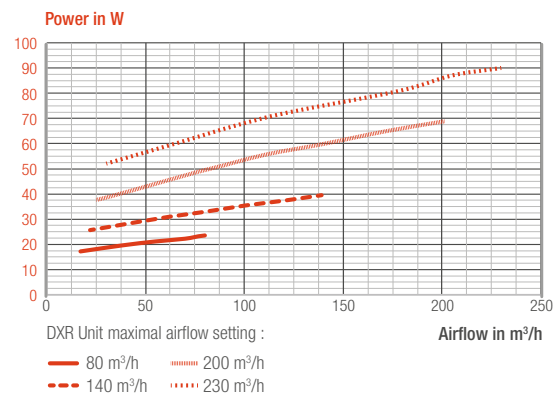
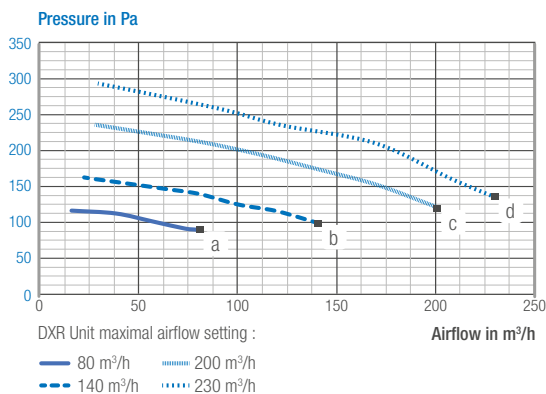



## DX SYSTEM DXA

Heat recovery unit for wall installation

**DCV** Contant pressure fitted to demand controlled exhaust units.

**DynamiX® Technology:** ensures a silent system and optimal indoor air quality\*.

**W** Very low energy consumption by combining demand control of airflows and heat recovery.

**Screwdriver icon** Easy installation in cupboard spaces thanks to its optimal dimensions.

**Trapdoor icon** Easy maintenance of the filters through designed trapdoors.

**Recycling icon** Body made of EPP, an environmental friendly material.

\*specific to Excellence version



### Heat recovery with demand control for wall installation

The DXA has been specifically designed for wall or cupboards installation. Thanks to its well-fitted dimensions, the DXA can be installed both in kitchen and in other technical rooms, wall-mounted. A creamy white metal sheet covers the front face of the the DXA which allows it to be unnoticed as a technical equipment. The DXA unit is compatible with two demand control strategies used in the DX System “Premium” and “Excellence”.

### Indoor Air Quality at its best (1) **DynamiX® Technology**

The DXA enhances indoor comfort by providing healthy air, at a milder temperature, preheated by the integrated heat exchanger. To feel good at home, the DynamiX® Technology, available on “Excellence” version, adapts, at any time, both supply and exhaust airflows to the occupants needs in every room through accurate sensors (CO<sub>2</sub> or presence). The DynamiX® Technology is a smart demand control strategy specific to the DX System which follows two main purposes: to reduce inherent noise from the heat recovery system while guaranteeing the best Indoor Air Quality.

### Sustainability (2)

The main material used to produce the DXA, the EPP (Expanded Polypropylene), is a “green” material, environmentally friendly, 100% recyclable. It does not include any VOC (volatile organic compound), CFC (chlorofluorocarbon) or other compounds known to be particularly harmful to the environment.

### Easy to maintain (3)

Three filters can be easily replaced without dismantling the unit, by simply removing the trapdoors. Filter durability is doubled compared to traditional heat recovery systems, notably thanks to a very large surface of filtration and demand controlled airflows. A touch screen interface enables to set the system and to warn for maintenance.



1



2

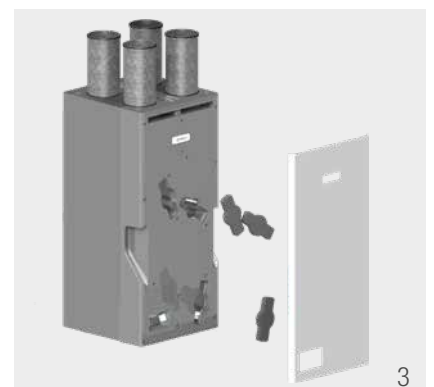

3



# DXA Heat recovery unit for wall installation



<b>Standard code</b>	
<b>Ecodesign</b>	
Label (EU Ecodesign Directive)	
<b>Airflow characteristics</b>	
Max. airflow	m <sup>3</sup> /h
Other nominal airflows	m <sup>3</sup> /h
Pressure at exhaust	Pa
Airflow compensation (filter clogging)	
Airflow balance (supply and exhaust)	
<b>Acoustics</b>	
Sound power level Lw @ 161 m <sup>3</sup> /h, 50 Pa	dB(A)
Sound power level Lwa [ a / b / c / d ]	dB
<b>Electrics</b>	
Power supply	
Motor type	
Power consumption @ 161 m <sup>3</sup> /h @50 Pa	W
Power consumption @ 230 m <sup>3</sup> /h @50 Pa	W
Sensors connections	
<b>Demand control</b>	
Compatible versions of DX System	
Min - Max Number of sensors for modulation at supply	
Min - Max Number of sensors for modulation at exhaust	
Sensors type at supply	
Exhaust units type	
<b>Characteristics</b>	
Exchanger	
Filters	
Weight	kg
Colour	
Material (main)	
Dimensions	mm
Certifications	
<b>Installation</b>	
Max. number of main rooms	
Max. number of technical rooms	
Connections	
Installation	
<b>Other functions (in option)</b>	
Interface	
Bypass	
Preheating (optional)	
Condensation management	
<b>Temperature of use</b>	
Installation room	
Incoming outdoor fresh air or Extract	

	DXA 230
	DXA1240      DXA1247
	A+ (with 2 IAQ sensors)
Max. airflow	230
Other nominal airflows	80 / 140 / 200
Pressure at exhaust	60
Airflow compensation (filter clogging)	automatic
Airflow balance (supply and exhaust)	automatic
Sound power level Lw @ 161 m <sup>3</sup> /h, 50 Pa	52
Sound power level Lwa [ a / b / c / d ]	49 / 54 / 59 / 60
Power supply	230 VAC, 50 Hz
Motor type	EC (x2)
Power consumption @ 161 m <sup>3</sup> /h @50 Pa	36,5
Power consumption @ 230 m <sup>3</sup> /h @50 Pa	92,0
Sensors connections	RJ12
Compatible versions of DX System	Premium / Excellence
Min - Max Number of sensors for modulation at supply	1 - 5
Min - Max Number of sensors for modulation at exhaust	1 - 5
Sensors type at supply	presence / CO <sub>2</sub>
Exhaust units type	humidity / presence / switch / CO <sub>2</sub> / VOC
Exchanger	polystyrene / counter flow type / 93% efficiency
Filters	on supply air: 2 x F7 / on exhaust air: 1 x G4
Weight	23
Colour	white
Material (main)	expanded polypropylene (EPP) covered by a white galvanized metal sheet
Dimensions	with duct connectors: 1428 x 552 x 545      without duct connectors: 1188 x 552 x 545
Certifications	CE
Max. number of main rooms	6
Max. number of technical rooms	5
Connections	2 x (2 x ø160 mm)
Installation	vertical only, to the wall / 2 x 4 points of attachment
Interface	2,8" colour touch screen interface / can be built-in or fixed separately
Bypass	controlled by outdoor temperature / also used for free cooling
Preheating (optional)	with resistance in fresh air ductwork from outside
Condensation management	condensate pump      exhaust through siphon
Installation room	frost free: +5°C < T° < +50°C
Incoming outdoor fresh air or Extract	-5°C < T° < +50°C without preheating      -26°C < T° < +50°C with preheating

for other components: see designation on page 30

Pressure in Pa

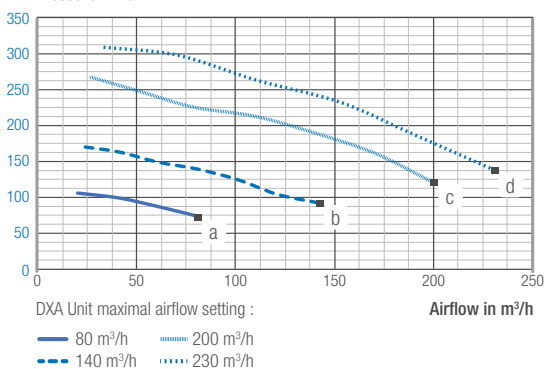



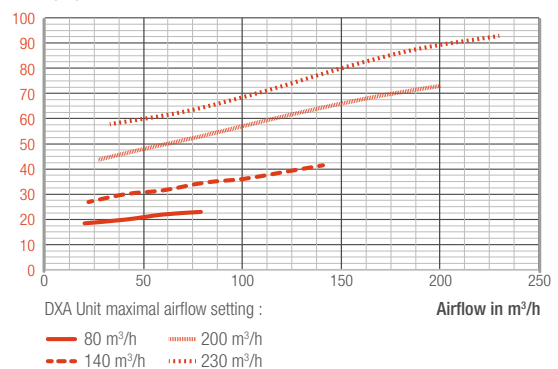

Power in W





## DX SYSTEM DX HUB

Active air supply distribution box

-  **DynamiX® Technology:** ensures a silent system and optimal indoor air quality through room-by-room demand control.
  -  **Noise attenuation through low pressure operation (DX Hub 5) and built in silencers (DX Hub 6).**
  -  **Easy installation thanks to multiple positioning.**
  -  **Easy maintenance with all metal parts unscrewable.**
- High-quality manufacture with main parts made of metal.**

\*specific to DX Hub 5



### How does the DX System control room-by-room supply and exhaust airflows

If the units used for exhaust are the same as those used in Aereco’s mechanical exhaust ventilation system, the airflow supply in the DX System “Excellence” is controlled by a specific device: the DX Hub distribution box. Using up to 5 or 6 demand controlled dampers connected to supply units, it allocates the airflow in each room according to the data received by CO<sub>2</sub> or presence sensors located in bedrooms and in the living room. An additional valve\* is integrated to ensure the balance between total exhaust and supply air.

#### DX Hub range

Two products complete the DX Hub range, both are compatible to DXR and DXA. The DX Hub 5, with its outlets of D100 mm, fits perfectly for galvanized ductwork, while the DX Hub 6, with its outlets of D75 mm, is more dedicated to installation with semi-flexible ducts.



The DX Hub is the pillar of the DynamiX® Technology. With a very accurate and smart management of motorized dampers and with acoustic silencers (DX Hub 6), it ensures a soundless operation by the DX System.

#### Installation (1)

Thanks to the multiple localization of their inlets, it has never been so easy to install a heat recovery ventilation system. Whatever the heat recovery unit, the DX Hubs can be installed in a vertical or horizontal position. With different mounting brackets, the DX Hub range suits for both ceiling and wall mounting.





<b>Standard code</b>	
<b>Airflow characteristics</b>	
Pressure at supply	Pa
Acoustics	
Phonic enveloppe	
Phonic silencers	
<b>Electrics</b>	
Electrical connections (sensors)	
<b>Characteristics</b>	
Weight	kg
Dimension	mm
Colour	
Material (main)	
Inlet duct connections (to DXR or DXA)	
Outlet duct connections (to the supply units)	
<b>Installation</b>	
Installation	
Installation room	
In option	

## DX HUB 5 Active air supply distribution box

	<b>HUB1288</b>
	25
	■
	-
	5 x RJ12
	10,9
	592 x 490 x 206
	metal
	galvanised steel with phonic and thermal insulation
	choice among 2 x ø160 mm
	5 x ø100 mm + 1 x ø125 mm
	horizontal or vertical
	frost free: +5°C < T° < +50°C
	fixing system for DX System. See p. 101



<b>Standard code</b>	
<b>Airflow characteristics</b>	
Pressure at supply	Pa
Acoustics	
Phonic enveloppe	
Phonic silencers	
<b>Electrics</b>	
Electrical connections (sensors)	
<b>Characteristics</b>	
Weight	kg
Dimension	mm
Colour	
Material (main)	
Inlet duct connections (to DXR or DXA)	
Outlet duct connections (to the supply units)	
<b>Installation</b>	
Installation	
Installation room	
In option	

## DX HUB 6 Active air supply distribution box

	<b>HUB1434</b>
	65
	■
	■
	5 x RJ12
	18
	695 x 684 x 199
	metal
	galvanised steel with phonic and thermal insulation and acoustic silencers
	choice among 3 x ø160 mm
	6 x ø75 mm
	horizontal or vertical
	frost free: +5°C < T° < +50°C
	fixing system for DX System. See p. 101

# DX SYSTEM Whole-house smart heat recovery ventilation range

**DXR Unit** - Dimensions in mm

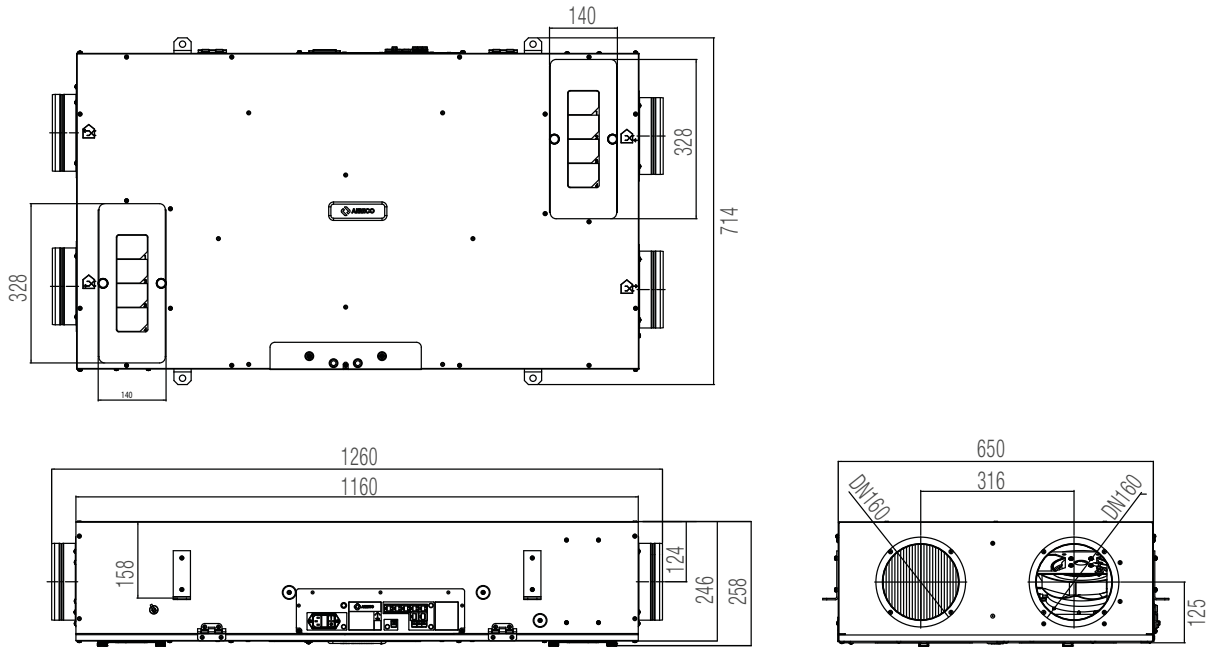

**DXA Unit** - Dimensions in mm

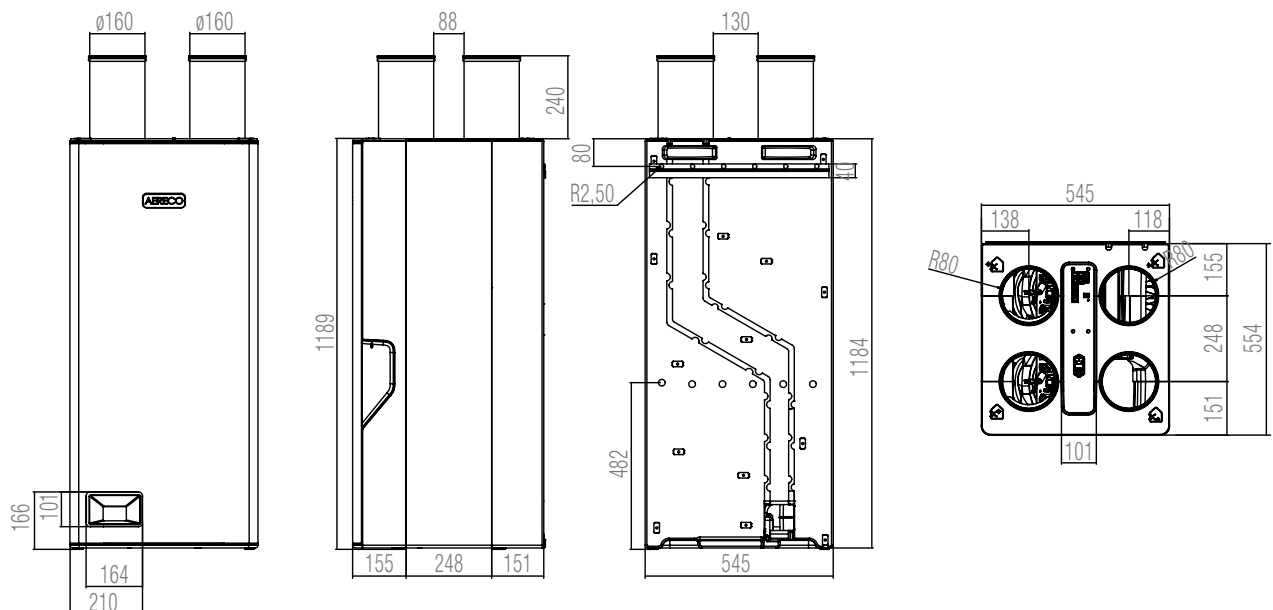

Hub 5 - Dimensions in mm

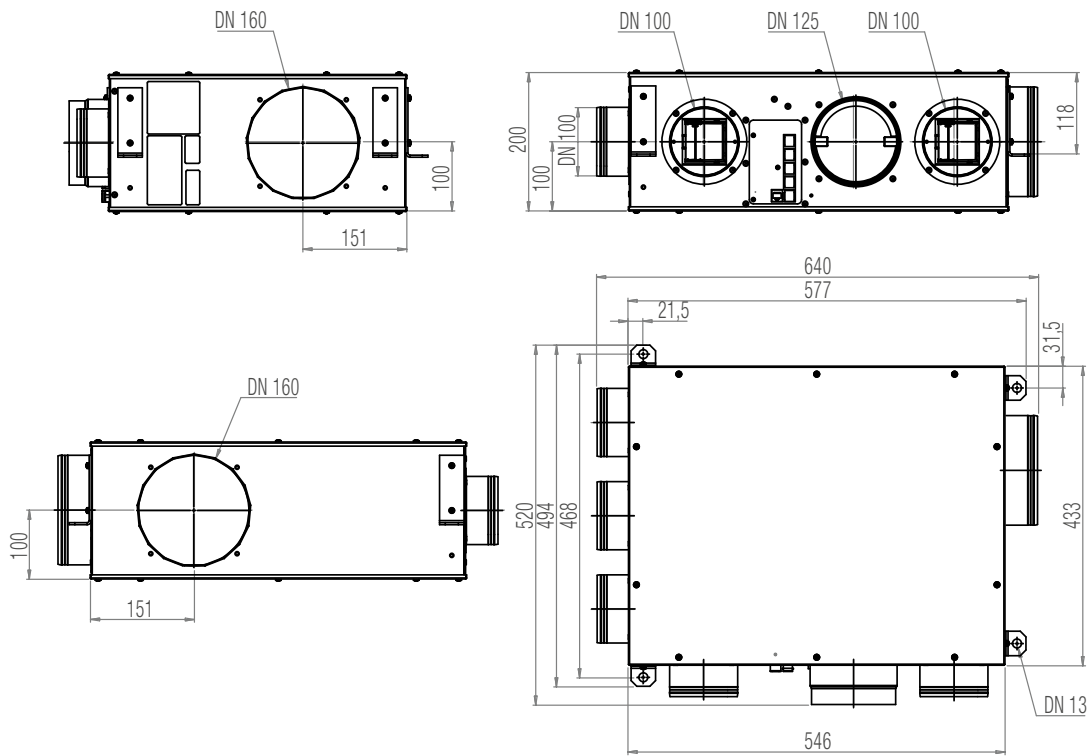

Hub 6 - Dimensions in mm

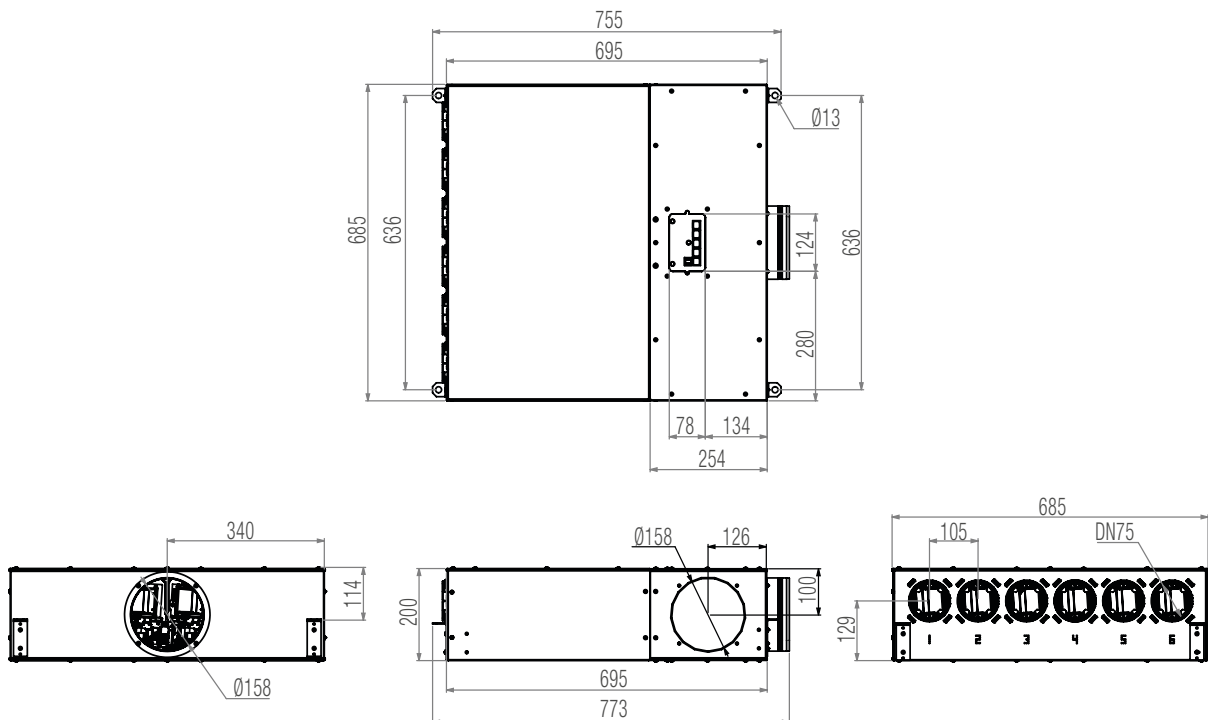

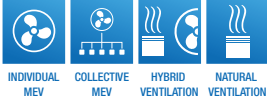

# S-SERIE

Indoor air quality sensors with digital and analog outputs



Accurate device to measure CO<sub>2</sub> concentration reliably.



Accurate measurement of VOC concentration and odors.



Digital humidity and temperature sensor.

2 outputs for easy connection: analog (0-10V) and digital (PWM).



Can be adapted to different markets and applications.



Compact design, simple to install, ready to use.



No maintenance.

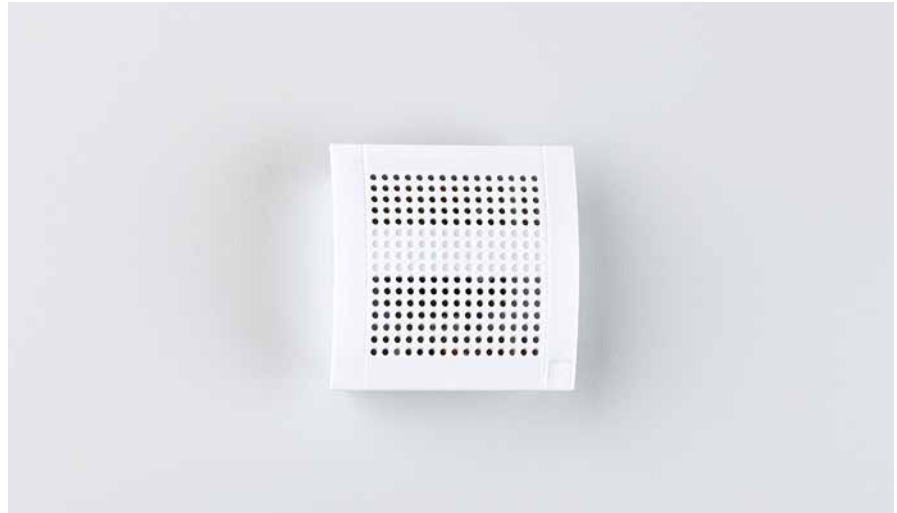

## A reliable solution engineered to accurately measure indoor air quality

Aereco introduces its new range of sensors to measure the concentrations of CO<sub>2</sub>, VOCs and humidity to control buildings HVAC system. Fully calibrated, the three sensors can be easily integrated to your HVAC system to guarantee a smart and simple building management.

### S-CO2, a reliable and accurate device that enables systems to optimize indoor air quality

Indoor air quality can generally be assessed by measuring the concentration of carbon dioxide, known to be representative of indoor air conditions. The S-CO2 is useful in many places (such as schools, office buildings, and private homes) where the concentration of CO<sub>2</sub> can vary with the occupancy and use of the rooms. Its technologies ensure long-term stability and performance: the S-CO2 is pre-calibrated to measure, in real time, indoor CO<sub>2</sub> concentrations from 0 to 2000 ppm, and it delivers both analog (0-10 V) and digital (PWM) output signals. Thanks to its dual-beam measurement technology, the S-CO2 can be placed in any room, at any time, whatever the installed system. The Aereco CO<sub>2</sub> sensor integrates the NDIR technology, a selective auto-calibrated technology that allows a good assessment of the indoor air quality.

### S-VOC, a smart sensor for holistic assessment of indoor air quality

The S-VOC is designed to accurately and reliably assess the level of volatile organic compounds (VOCs) typically associated with cigarette smoke, cooking smells and other pollutants. Using the MOS technology, the S-VOC measures the concentration of VOC and odours at a real time and evaluates the CO<sub>2</sub> level of the room (see graph below). Its output signal reports values from 0 to 2000 on a “ppm CO<sub>2</sub> equivalent” IAQ scale. This output signal is available simultaneously in two forms: analog (0-10V) and digital (PWM).

### S-RH/T, a versatile unit that measures humidity and temperature

The S-RH/T is designed for applications such as demand-controlled ventilation and air conditioning where accurate measurements, excellent long-term stability, and maintenance free-operation are absolute musts. The temperature and humidity measurements are available simultaneously to optimize their contribution to comfort and health.

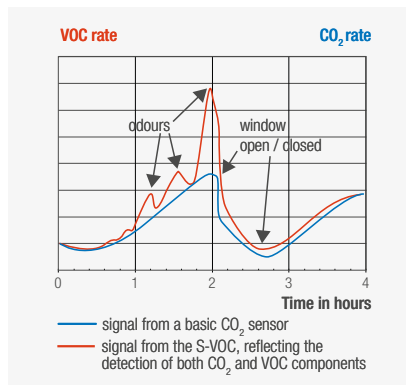



# S-SERIE Indoor air quality sensors with digital and analog outputs





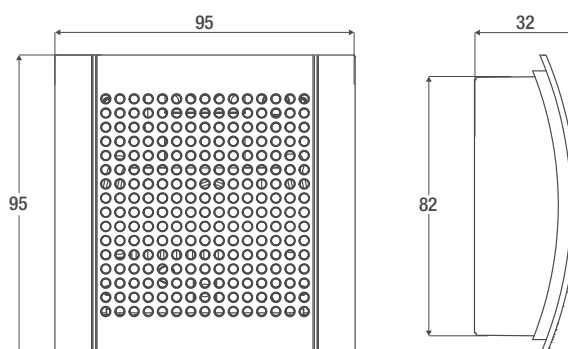





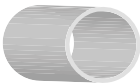
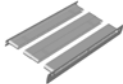

		<b>S-CO2</b>	<b>S-VOC</b>	<b>S-RH/T</b>
		<b>CAP1159</b>	<b>CAP1160</b>	<b>CAP1161</b>
<b>Standard code</b>				
<b>Measurement principle</b>		<b>Non-Dispersive Infrared Technology (NDIR), Dual-Source Infrared System</b>	<b>Micro-machined metal oxide semiconductor (MOS) technology</b>	<b>Capacitive humidity sensor Band gap temperature sensor</b>
<b>Working range</b>		0... 2 000 ppm CO <sub>2</sub>	0...2 000 ppm CO <sub>2</sub> eq	0°C +50°C 0 % - 100 % Relative Humidity
<b>Accuracy at 25°C and 1 013 mbar</b>	ppm	± (60 ppm +2 % of measured value in a [0 ppm; 2000 ppm] range)	-	-
<b>Response time</b>	s	< 195 s	-	-
<b>Temperature dependence</b>	CO <sub>2</sub> / °C	typ. 2 ppm CO <sub>2</sub> / °C (0...50°C)	-	-
<b>Long-term stability</b>	ppm / year	typ. 20 ppm / year	-	-
<b>Precision RH</b>		-	-	typical +/-2,5 %, max +/-3,5 % RH at 25°C in 20 % -80 % range
<b>Accuracy of temperature</b>		-	-	max +/-0,6°C in [5°C ; 50°C] range, typical 0,5°C
<b>Measurement reporting interval</b>	s	60 s	60 s	60 s
<b>Supply voltage</b>	VDC	12 VDC +/- 10 %.	12 VDC +/- 10 %	12 VDC +/- 10 %
<b>Average power consumption</b>	A	120 mA (reading), 10 mA (base).	40 mA	15 mA
<b>Max. peak current</b>	A	1 A (use for fuse sizing)	1 A (use for fuse sizing)	1 A (use for fuse sizing)
<b>Enclosure protection</b>		IP 20	IP 20	IP 20
<b>Storage conditions</b>		-40...60°C 5...95 % RH (without condensating) 85...110 kPa	-25...50°C 5...95 % RH (without condensation) 85...110 kPa	10...50°C 0...60 % RH
<b>Working conditions</b>		-40...60°C 5...95 % RH (without condensating) 85...110 kPa	0...50°C 5...95 % RH (without condensation) 85...110 kPa	-
<b>PWM digital output</b>				
<b>Output data</b>	ppm	0 % = 0 ppm ; 100 % = 2 000 ppm	0 to 100 % 0 % = 0 ppm CO <sub>2</sub> eq ; 100 % = 2 000 ppm CO <sub>2</sub> eq	0 to 100 % 0 % = 0 % RH - 100 % = 100 % RH 0 % = 0°C - 100 % = + 50°C
<b>Voltage</b>	VDC	12 VDC +/- 10 %.	12 VDC +/- 10 %.	12 VDC +/- 10 %
<b>Frequency</b>	KHz	1 KHz	1 KHz	1 KHz
<b>0-10 V analog output</b>				
<b>Output data</b>		0 to 10 V. 0 V = 0 ppm ; 10 V = 2 000 ppm	0 to 10 V 0 V = 0 ppm CO <sub>2</sub> eq ; 10 V = 2 000 ppm CO <sub>2</sub> eq	0 to 10 V 0V = 0 % RH - 10 V = 100 % RH 0V = 0°C - 10 V = + 50°C
<b>Voltage</b>	V	0 to 10 V	0 to 10 V	0 to 10 V
<b>Required impedance</b>	Ω	>1MΩ	>1MΩ	>1MΩ
<b>Characteristics</b>				
<b>Weight</b>	g	80.5 g	80.5 g	80.5 g
<b>Colour</b>		white	white	white
<b>Material</b>		ABS	ABS	ABS

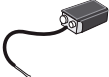











Dimensions in mm



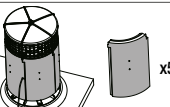
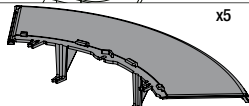















# ACCESSORIES

	Code	Description	Related product
<b>Air inlets</b>			
	AEA776	Wall plastic sleeve $\varnothing$ 100 mm L.350 mm	EHT
	AEA967	Acoustic foam for $\varnothing$ 125 mm duct, 48 dB (x2 kit)	EHT
	AEA968	Acoustic foam for $\varnothing$ 100 mm duct, 43 dB (x2 kit)	EHT
	see page 49	Window telescopic sleeve for air inlets (EMM – EMM <sup>1</sup> – EHA – EHA <sup>2</sup> )	EMM – EHA EHA <sup>2</sup> – EMM <sup>2</sup>
	AEA774	F-EHT, Removable filter for $\varnothing$ 100 mm tube	EHT
	AEA064	ACW, Airflow controller: limits the airflow to 40 m <sup>3</sup> /h EHT, round wall air inlets, for $\varnothing$ 100 mm tube	EHT
	AEA086	$\varnothing$ 125 mm adaptor for ACW related product	EHT
<b>Exhaust units</b>			
	CAL195	Supply device 12 VAC / 9 VDC (mandatory for 12 VAC supply)	G2H
	CAL261	Supply device 12 VAC / 3 VDC (mandatory for 12 VAC supply)	BXC
	AEA478	Remote control for boost airflow activation	BXC rc – BXC hrc G2H rc – G2H hrc
	33007AL	Trident plastic sleeve $\varnothing$ 125 mm - L 125 mm	BXC – TDA
	85343AL	Trident plastic sleeve $\varnothing$ 125 mm - $\varnothing$ 80 mm - L 125 mm	BXC
	FBE1089	Aluminium filter box with washable filter for exhaust units	BXC
	19429AL	Phonic ring for exhaust units $\varnothing$ 125 mm	BXC
	BHM429	Phonic plate for exhaust units $\varnothing$ 125 mm	BXL
	AEA317	Plastic adaptor $\varnothing$ 125 mm, black, with joint	BXC
	AEA317	CAF: stops the propagation of fire cold smokes through ventilation ducts. For BXC only. $\varnothing$ 125 mm	BXC

Exhaust fans	Code	Description	Related product
	AEA877	Connecting spigot for Ø125 mm duct	V2A
	SE3203	Connecting spigot for Ø100 mm duct	V2A
	AVE055	Connecting spigot for Ø125 mm duct	V4A
	AVE056	Connecting spigot for Ø100 mm duct	V4A
	AEA808	Metal sleeve Ø125-125 mm L.80 mm	VAM
	AEA809	Metal sleeve Ø125-100 mm L.100 mm	VAM
	AEA810	Metal sleeve Ø125-80 mm L.110 mm	VAM
	VBP070	Thermal protection shell - set for 1 VBP fan	VBP
	VBP335	Rain protection - set for 1 VBP fan	VBP
	VBP447	Rain exhaust base sleeve	VBP
	AVE197	Complete supply and control box (from 1 to 3 VBPms)	VBPms
	AVE198	Complete supply and control box (from 4 to 6 VBPms)	VBPms
	VB21119	Electronic module for MS system (MAIN module)	VBP+
	VB21118	Electronic module for MS system (FAN module)	VBP+
	AVE1146	Numerical thermal sensor for MS system	VBP+

DX System	Code	Description	Related product
	SDC1107	Supply unit for Ø100 mm duct	DX System
	SDC1108	Supply unit for Ø125 mm duct for balance airflow	DX System
	CAP1100	S-CO2: CO <sub>2</sub> sensor. Connection RJ12	DX System
	CAP1101	S-PRE: Presence sensor. Connection RJ12	DX System
	BFX1114	BXC b: Exhaust unit for balance airflow	DX System
	ADX1224	Exhaust compensation valve for DX system. Connection RJ45	DX System
	ADX1098	Electrical preheater 1200 W. Aereco specific cable	DX System
	ADX1099	Condensate pump for DXR. Aereco specific cable	DX System
	ADX1254	DXR filter kit. Contains 1xG4 and 1xF7	DXR
	ADX1428	DXA filter kit. Contains 1xG4 and 2xF7	DXA
	ADX1197	RJ45 cable, length 5 m	DX System
	ADX1123	RJ45 cable, length 10 m	DX System
	ADX1249	RJ12 cable, length 5 m	DX System
	ADX1250	RJ12 cable, length 10 m	DX System
	ADX1251	RJ12 cable, length 20 m	DX System
	ADX1252	RJ12 cable, length 30 m	DX System
	ADX1106	Vertical fixing system for DX System. Compatible with DX Hub 5 and DX Hub 6. 4 cables each with a length of 3 m	DXR / DX HUB
	ADX1449	Design cover for inlet and outlets ducts of DXA	DXA
	ADW1167	Acoustic silencers	DXR / DXA

DX System	Code	Description	Related product
	IHM1195	Remote colored touchscreen interface. Connection RJ12	DXR Premium version
	IHM1438	Integrated colored touchscreen interface. Connection RJ12	DXA Premium version
	IHM1439	Remote colored touchscreen interface. Connection RJ12	DXA Premium version
	IHM1293	Remote colored touchscreen interface. Connection RJ12	DXR Excellence version with DX HUB 5
	IHM1294	Integrated colored touchscreen interface. Connection RJ12	DXA Excellence version with DX HUB 5
	IHM1295	Remote colored touchscreen interface. Connection RJ12	DXA Excellence version with DX HUB 5
	IHM1362	Remote colored touchscreen interface. Connection RJ12	DXR Excellence version with DX HUB 6
	IHM1440	Integrated colored touchscreen interface. Connection RJ12	DXA Excellence version with DX HUB 6
	IHM1441	Remote colored touchscreen interface. Connection RJ12	DXA Excellence version with DX HUB 6





# APPENDIX



Applied to two new buildings erected in Paris and near Lyon in 2007, the Performance project created an opportunity to measure precisely the efficiency of humidity sensitive mechanical exhaust ventilation in general, and of the Aereco DCV system in particular, in a large set of dwellings.

A total of 30 occupied dwellings were monitored for two years beginning in November 2007 to measure representative energy consumption and indoor air quality parameters. This monitoring led to a better understanding of the parameters that may influence ventilation performance.

On-going measurement, study, and analysis of ventilation behaviour in order to optimise the performance of our systems is, and will always be, a major concern at Aereco. By comparing theory and practice, field experiments and studies conducted in many countries have added to our knowledge of ventilation and confirmed the performance of Aereco ventilation systems. The large scale “Performance” monitoring project enabled to test the Aereco mechanical ventilation system in-situ. Here are the main results.

### CO<sub>2</sub> concentrations lowered by Aereco ventilation system.

The measurements of CO<sub>2</sub> concentrations plotted in the histogram of figure 1 show that indoor air quality is maintained in a low-occupancy bedroom (one adult - light blue) and in a high-occupancy one (four adults - dark blue). The peak CO<sub>2</sub> concentration was shifted from 700 ppm in the low-occupancy bedroom to 950 ppm in the high-occupancy one, but even in the latter, the 1500 ppm level was exceeded for only a very few hours in the heating season.

The chart of figure 2 confirms the efficiency of the humidity sensitive air inlet on representative overnight variations compared with a simulated fixed ventilation system: **the humidity sensitive air inlet keeps the CO<sub>2</sub> level below 1500 ppm, but an air inlet with a fixed airflow would have led to a CO<sub>2</sub> level of over 2200 ppm.** The monitoring also created an opportunity to test the impact of the global system on indoor air quality: the fan was stopped for a short period (one month) and the CO<sub>2</sub> concentrations were compared with the other months (with ventilation) of the heating season. **The histogram of figure 3 clearly shows the value of the ventilation and its positive impact on IAQ.** When the fan was stopped, a strong rise in CO<sub>2</sub> concentrations (above 1900 ppm most of the time) was observed. The occupants did not react to compensate for the lack of air renewal. **This confirms the impact of ventilation on IAQ and shows that occupants are unaware of poor ventilation and fail to compensate, for instance by opening windows.**

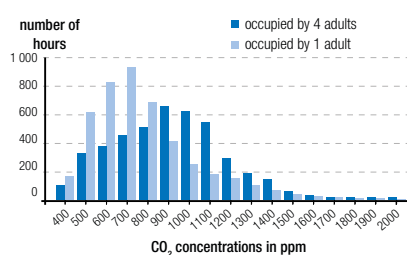

Figure 1: CO<sub>2</sub> concentrations in two bedrooms with different occupancy levels.

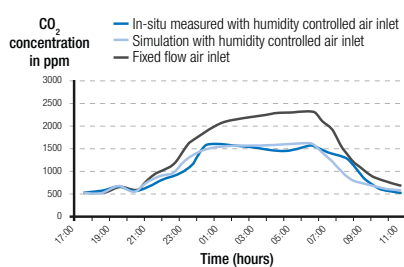

Figure 2: overnight variation of CO<sub>2</sub> concentrations in a bedroom. Comparison of Humidity Controlled (HC) air inlet (measured and simulated) and fixed-flow air inlet (simulated).

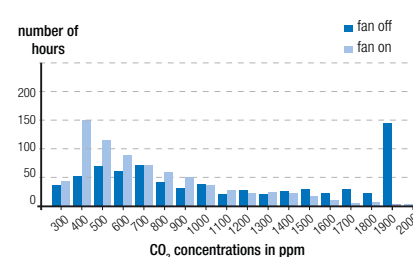

Figure 3: CO<sub>2</sub> concentrations with / without ventilation. Measurements for one month with fan off in a bedroom compared with fan-on for the rest of the heating season. 3 occupants in a bedroom.

# MONITORING THE PERFORMANCE OF THE DEMAND CONTROLLED MEV SYSTEM

## Approximately 30% energy savings on ventilation with the Aereco DCV system

The chart of figure 4 presents the average equivalent-heat-loss airflow for every dwelling in the monitoring sample during a complete heating season. The dwellings are grouped by type (number of main rooms). The differences in measured airflows result from the adaptation of the ventilation systems to different occupancy levels, activities, occupant behaviours, and dwelling sizes. The comparison with the French regulatory reference (fixed airflow, black bars) shows the statistical airflow reduction – thus the energy savings – with the DCV system. The measured savings on the airflow in this project are evaluated at 30%. But a survey showed that most of these dwellings are over-occupied, especially on the Paris site. When this result is extrapolated to the statistical average French occupancy for each type of dwelling, the result is about 55% energy savings on ventilation heat losses. This statistical airflow reduction does not affect the IAQ; indeed, the IAQ, in terms of CO<sub>2</sub> and humidity, has been shown to be better, as stated earlier.

## Results

The large scale in-situ monitoring of 30 dwellings demonstrated the good performance of the Aereco DCV system tested: a high level of indoor air quality compared to a fixed ventilation system. The condensation risks are negligible; the monitored system yielded 30% energy savings compared with the regulatory fixed airflow in these over-occupied dwellings. An extrapolation to the statistical average French occupancy indicates 55% energy savings on heat losses. Fan energy consumption was reduced by between 35% and 50% on both sites. In addition, the in-situ working characteristics of the monitored DCV terminals were consistent with the laboratory test results.

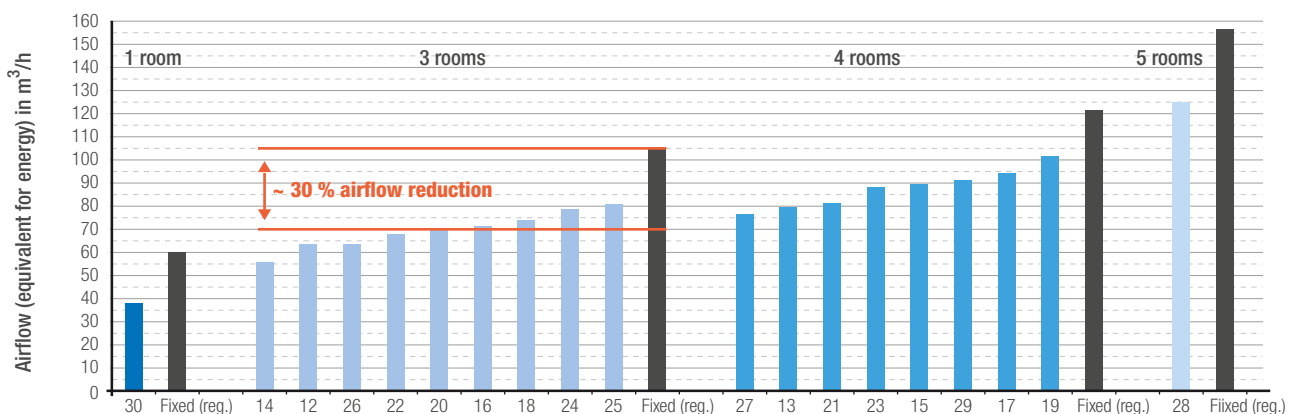

Figure 4: statistical equivalent-heat-loss airflows per dwelling (numbers in abscissa) on Paris site. Rated by dwelling types by comparison with the constant airflow required by French regulations (black). 2007-2008 heating period.



# AERECO DEMAND CONTROLLED MEV<sup>1</sup>: A RELEVANT, LOW-COST ALTERNATIVE TO CONSTANT HEAT RECOVERY VENTILATION

## Environmental benefits

The energy performance of Aereco's demand controlled MEV system is reinforced by the fact that its single fan consumes less electricity than the two fans and preheating of the heat recovery system. With a PE-factor<sup>1</sup> of 2.7, **the impact on primary energy consumption – and so on CO<sub>2</sub> emissions – favours humidity controlled ventilation for the share of energy necessary to run the system.**

## Indoor air quality

This study also showed that, under real occupancy conditions, **Aereco demand controlled MEV keeps CO<sub>2</sub> levels below 1200 ppm, guaranteeing optimal indoor air quality (IAQ) in the dwelling (graph no. 3).**

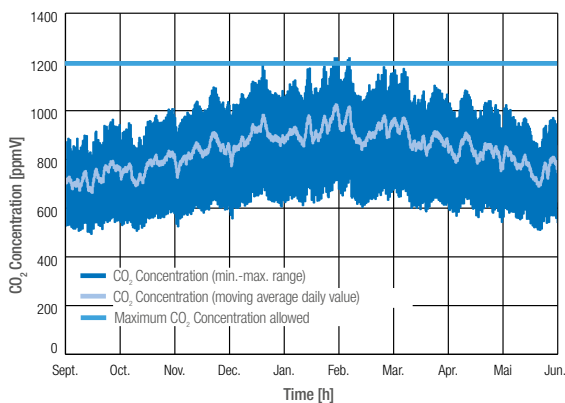

**graph no. 3** - Daily variation of CO<sub>2</sub> inside the dwelling equipped with Aereco demand controlled MEV

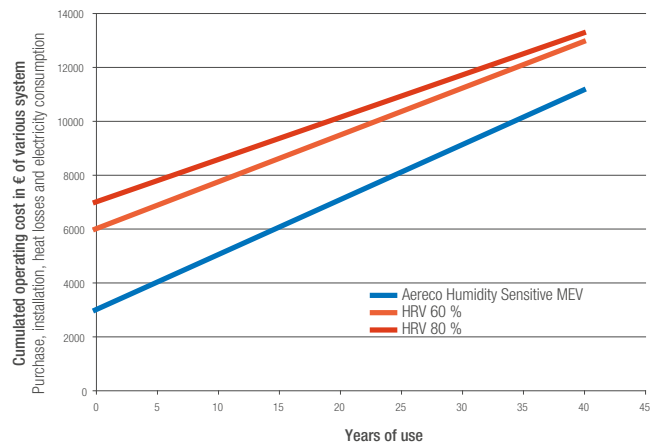

**graph no. 1** - Operating costs and R.O.I.<sup>2</sup> of various ventilation systems  
Assumption: 1 kWh = €0.10 +VAT

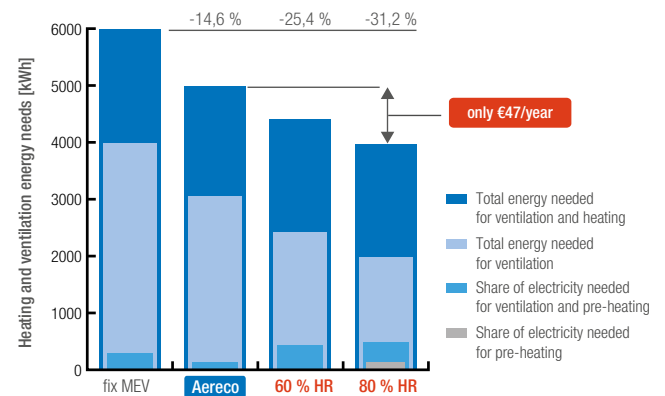













**graph no. 2** - Total energy consumption of various ventilation systems  
Assumption: 1 kWh electricity = €0.19; 1 kWh Fuel oil or Gas = €0.07

1. PE = primary energy factor for electricity, value for Germany  
2. R.O.I.: return of investment

# VENTILATION SYSTEMS AND PRODUCT BREAKDOWN

The table below breaks the products down by type of ventilation in the residential application.

								
		Natural (PSV)	Hybrid	Low pressure MEV (LP MEV)	Mechanical (MEV), collective	MEV with HR	Mechanical (MEV), individual	Heat recovery (MVHR)
Air inlets 1 per room*	Bedroom 	air inlets + canopy	air inlets + canopy	air inlets + canopy	air inlets + canopy	air inlets + canopy	air inlets + canopy	SDC
	Living room 	air inlets + canopy	air inlets + canopy	air inlets + canopy	air inlets + canopy	air inlets + canopy	air inlets + canopy	SDC
Exhaust units 1 per room	Kitchen 	GHN or G2H	GHN or G2H	GBP	BXC	BXC	BXC	BXC
	Bathroom 	GHN or G2H	GHN or G2H	GBP	BXC	BXC	BXC	BXC
	Bathroom with toilets 	GHN or G2H	GHN or G2H	GBP	BXC	BXC	BXC	BXC
	WC 	GHN or G2H	GHN or G2H	GBP	BXC	BXC	BXC	BXC
	Other wet rooms	GHN or G2H	GHN or G2H	GBP	BXC	BXC	BXC	BXC
Fans		-	VBP or VBP+	VTZ or VCZ	VTZ or VCZ	AWN DV or AWN RV	V2A, V4A, V5S, or VAM	DXR or DXA
	Pressure setting	-	10-30 Pa (ST mode) automatic (MS mode)	20-50 Pa	80-150 Pa	80-150 Pa	80-120 Pa	automatic
	Number	-	1 per vertical duct or group of vertical ducts	1 per group of ducts	1 per group of ducts	1 per group of ducts	1 per dwelling	1 per dwelling

## Remark:

The design of the ventilation system and the choice of components must always comply with the country's legal requirements concerning:

- fire safety
- building energy performance
- building acoustics
- ventilation airflows
- and other factors relevant to the ventilation system (connected gas appliances, etc.)

\*1 air inlet per 25 m<sup>2</sup> floor area

**Example 1:** floor surface of living room = 18 m<sup>2</sup> => 1 air inlet

**Example 2:** floor surface of living room = 32 m<sup>2</sup> => 2 air inlets

# WHICH PARAMETERS TO CONTROL THE EXHAUST AIRFLOWS?

Preferred exhaust unit activation modes according to type of room (recommendations). This list is not exhaustive: Aereco products are also used for other destinations.

	Airflow control parameter	Humidity	Presence	Presence (activation after 1mn)	Manual activation (switch, remote c. or pull cord)	Humidity + Manual activation (switch, remote c. or pull cord)	Humidity + presence	Humidity + presence (activation after 1mn)	Carbon dioxide (CO <sub>2</sub> )	Volatile Organic Compounds (VOC)	Constant Airflow
Suffix Code		h	p	pd	i or rc or c	hi or hrc or hc	hp	hpd	co <sub>2</sub>	voc	
Housing	Kitchen	++									
	Bathroom	++++			+	+++	+++	+++			
	WC		++++	++++	+	++	+++	+++	++	+++	
	Bathroom with WC	+	+			++	+++	++++		++	
	Laundry / other wet room	++++				+++		+			++
School	Classroom		+++	+			+	+	++++	++++	+
	Lavatories		++++	++++	+	++	+++	+++	++	+++	
Office	Office		+++	++++			++	++	++++	++++	+
	Meeting room		+++	++++	+		++	++	++++	++++	+
Fitness centre	Locker rooms	+++	++		+	++	+++	+++	++++	++++	+
	Shower rooms	++++			+	+++	+++	+++			++



GBP



BXC

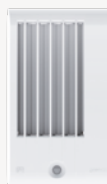

G2H



TDA



# CERTIFICATIONS & REGULATIONS

## ErP Directive

Commission Regulation (EU) No 1253/2014 and commission delegated regulation (EU) No 1254/2014 implementing Directive 2009/125/EC of 21<sup>st</sup> October 2009, respectively, relate to the implementation of ecodesign requirements for ventilation units and Labelling of residential ventilation units.

So, ventilation systems within the scope of this Directive, the ventilation units are being now subject to performance levels required by means of a new ErP (Energy-related Products) regulation.

The fans, which have a power consumption less than 30 W, are not subject to this regulation, as are extra ventilation systems (individual extractions eg bathroom) or which use only in exceptional surroundings (smoke control systems in case of fire, for example).

From 1<sup>st</sup> January 2016, both of these regulations will be applied, which means that all Aereco fans and HRV will have a product information sheet available from our website to characterize them.

This sheet, applied only to ventilation units defined as residential application, defines among other things their energy SEC class while for ventilation units defined as “non-residential”, this sheet will display their efficiency.

Energy labels will be attached to the products concerned to define their energy efficiency, their maximum flow rate and their sound power level. Among Aereco fan range, all are scored with the best energy labels which is from B class to A+ class.

The logo “ErP compliant” recalls that all fans Aereco covered by these rules comply with the requirements.

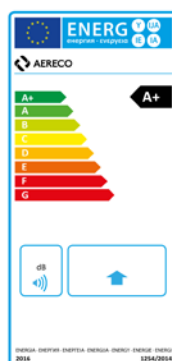
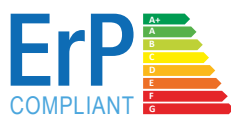

## Aereco S.A. is ISO 9001:2008 certified.

This certification means that Aereco's Quality Management System conforms to the version (2008) of the international quality standard. It covers the whole scope of the company's activities from the design, the manufacturing process to the sales operation.



## Aereco and the RoHS directive

Aereco guarantees through appropriated components specifications that all the general purpose electrical and electronical components<sup>3</sup> used in its products are conform<sup>2</sup> to the requirements of the EU RoHS Directive<sup>1</sup> 2011/65/EU.

## REFERENCES

Aereco ventilation systems cover various building applications and geographical locations, covering most of European countries as well as Russia, Japan and the United States notably. In new built or in renovation, for individual housing, block of flats or for commercial buildings, Aereco brings its know-how and experience to suit every project. Around 300 000 dwellings are equipped with Aereco systems every year, for a total since the birth of the company of more than 5 millions residences.





# AERECO GROUP

## Head office and factory

### France

Aereco S.A.  
62 rue de Lamirault  
COLLEGIEN  
77615 MARNE LA VALLEE  
CEDEX 3

tel.: +33 1 60 06 26 63  
fax: +33 1 64 80 47 26  
[www.aereco.com](http://www.aereco.com)

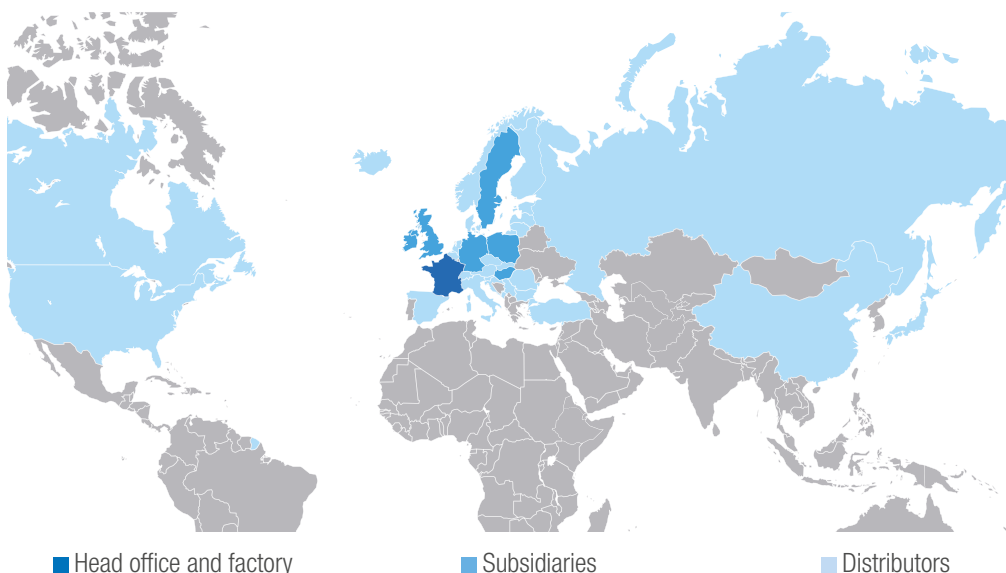

## Subsidiaries

### Germany

Aereco GmbH  
Robert-Bosch-Str. 9  
DE-65719 Hofheim-Wallau

tel.: +49 6122 92 768 30  
fax: +49 6122 92 768 90  
[info@aereco.de](mailto:info@aereco.de)

### Poland

Aereco Wentylacja Sp. z o.o.  
ul. Dobra 13  
Łomna Las  
PL-05152 Czosnów

tel.: +48 22 380 30 00  
fax: +48 22 380 30 01  
[biuro@aereco.com.pl](mailto:biuro@aereco.com.pl)

### Germany

ZLT GmbH  
Wilhermsdorfer Straße 28  
DE-09387 Jahnsdorf/Erzgeb.

tel.: +49 37296 9362-0  
fax: +49 37296 9362-50  
[info@zlt.de](mailto:info@zlt.de)

### Romania

Aereco Ventilatie srl.  
Str. Pericle Papahagi Nr.10-14  
Sector 3  
RO-032364 Bucarest

tel.: +40 21 345 41 65  
fax: +40 21 345 41 65  
[office@aereco.ro](mailto:office@aereco.ro)

### Hungary

Aereco Légtechnika Kft  
Fáy u. 20.  
HU-1139 Budapest

tel.: +36 1 214 44 21  
fax: +36 1 225 03 73  
[aereco@aereco.hu](mailto:aereco@aereco.hu)

### Russia (rep. office)

Aereco Russian Office  
Kostomarovskyi Per., 3,  
RU-105120 Moscow

tel.: +7 495 921 36 12  
fax: +7 495 921 36 12  
[aerum@aereco.ru](mailto:aerum@aereco.ru)

### Ireland + United Kingdom

Aereco Limited  
Cherrywood Business Park,  
Courtstown - Unit 1  
IRL - Little Island, Co. Cork

tel.: +353 21 429 60 30  
fax: +353 21 429 60 31  
[aereco@aereco.ie](mailto:aereco@aereco.ie)

### Sweden

Aereco Ventilation AB  
Lockarpsvägen 8  
SE-213 76 Malmö

tel.: +46 (0)40 626 66 60  
fax: +46 (0)40 685 45 55  
[info@aereco.se](mailto:info@aereco.se)

**Design:**

Aereco S.A. - Marketing Department

**Thanks:**

Aereco S.A. would like to thank BoConcept (Denmark) for their authorization to use their pictures.

**Copyright:**

© Aereco: p.2-9 / p.12-19 / p.22-23 / p.26-31 / p.33-35 / p.38 to the end (products and schemes)

© Ambiance et meubles BoConcept - [www.boconcept.com](http://www.boconcept.com): p.36

© Fotolia: p.1 / p.6 / p.20 / p.24 / p.32-33 / p.36

**Disclaimer:**

Whilst every effort has been reasonably made to ensure the accuracy of the information contained in this document, errors can occasionally occur. Aereco is not responsible for any reliance upon such information, any omissions or any subsequent loss or damage. Aereco reserves the right to amend, update or withdraw any information in this document without prior notice. All images and content in this document are a copyright of their owners and must not be reproduced without their express permission.



**Aereco S.A.**

62 rue de Lamirault – Collégien – 77615 MARNE LA VALLEE CEDEX 3 – FRANCE – tel. +33 1 60 06 26 63 – fax +33 1 64 80 47 26  
[www.aereco.com](http://www.aereco.com)