

the **precision** benchmark

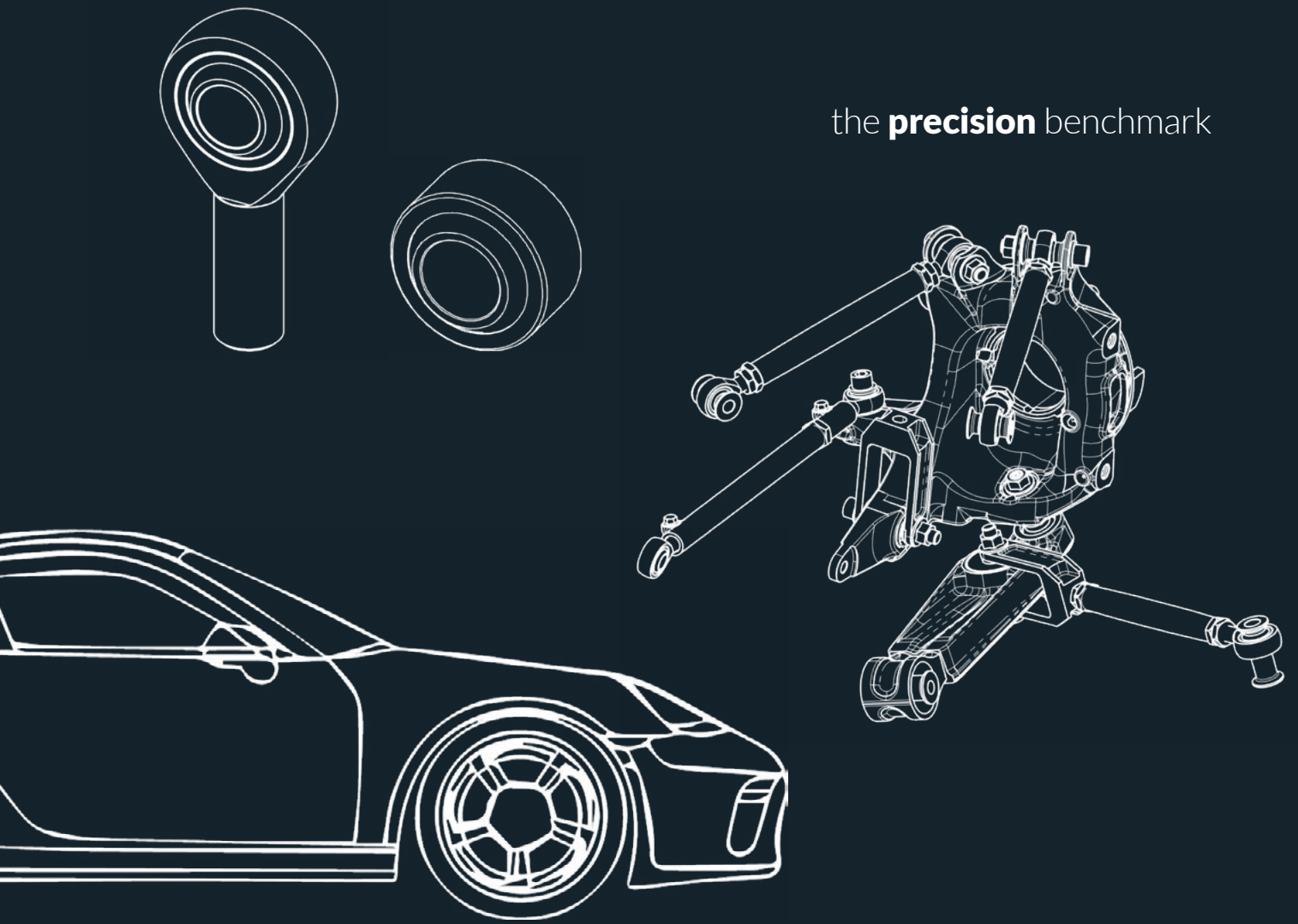

Spherical Bearings for Motor Sports

High-Performance Series

**CARL
HIRSCH
MANN** 

EN2050

Roll-in tool for bearings with V-groove

Advantages

- Low force effect, protecting the bearings
- No hydraulic press required
- Simple, as one box column drill is sufficient
- We can roll-in your bearings on request

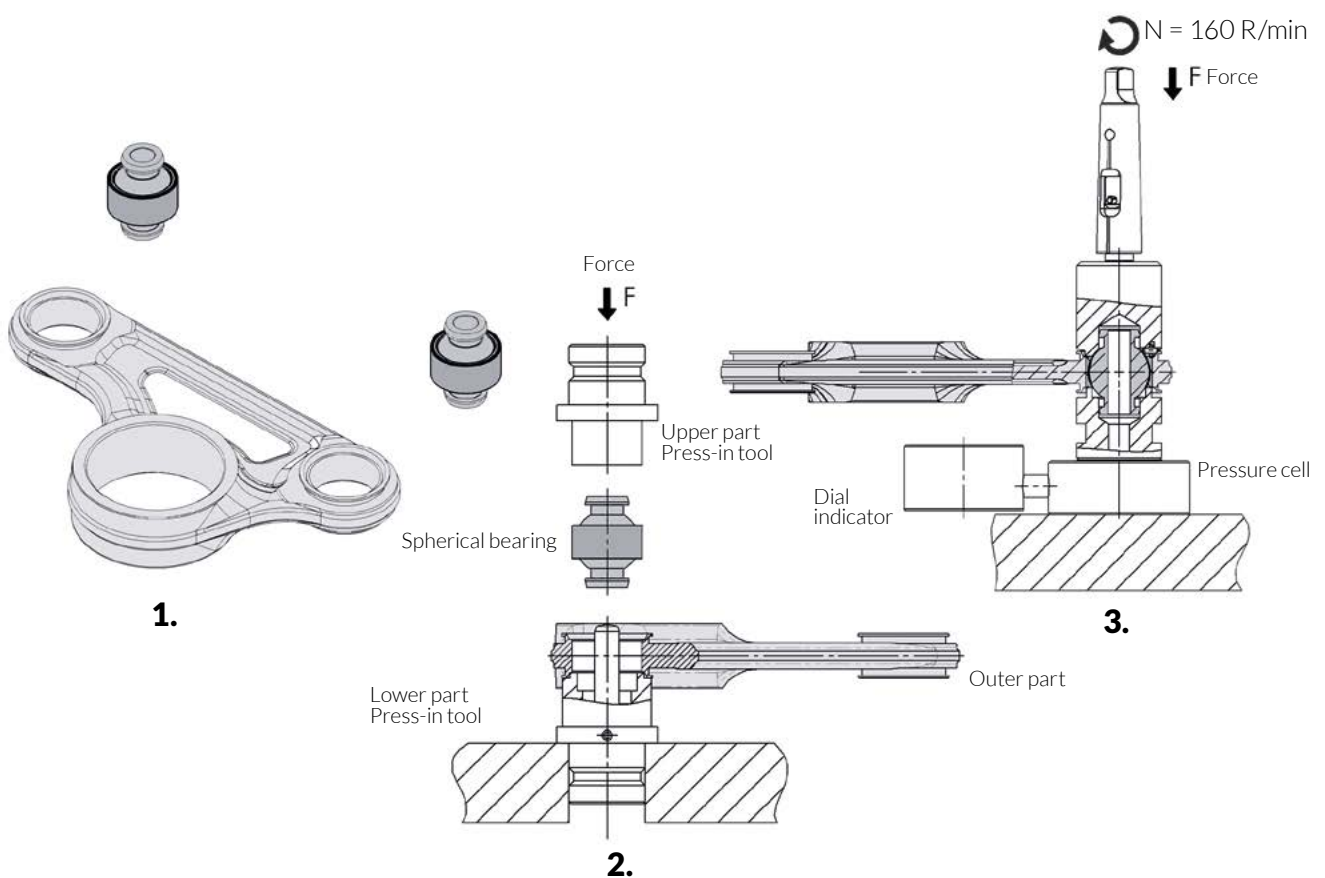

1. Part with bearing positions

- Outer part with defined bearing bores
- Spherical bearing with V-groove

2. Press-in tool

- Place the outer part on the lower part of the press-in tool
- Insert spherical plain bearings
- Press-in the spherical plain bearing through the upper part using a press

3. Roll-in tool

- Insert rolling head into drill chuck
- Place outer part with press-fitted bearing in fixture
- Roll-in/roll-up first side
- Turn part
- Roll-in/roll-up second side

A training as well as further details are available on request. Please do not hesitate to contact us.

Maintenance-free High-Performance rod ends with male thread

Series **SM(L)HP..**

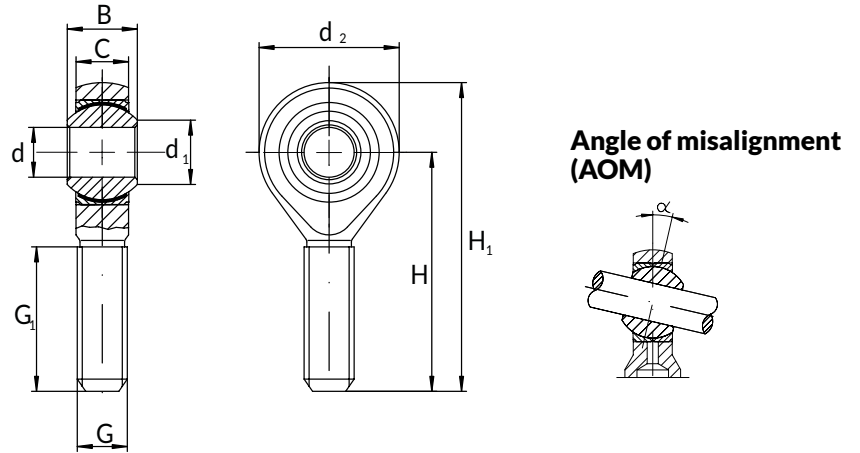

Type	d	B	C	d ₁	d ₂	H	H ₁	G ₁	K Ball ø	G Thread	Bearing capacities		Torque Nm	AOM α°	Weight each ≈g
											dynamic C	static C ₀ *			
6	6	9	6,75	8,9	20	36	46	22	12,700	M6	15 000	10 000	0,05 - 0,5	13	18
8	8	12	9	10,4	24	42	54	25	15,875	M8	25 000	18 000	0,2 - 1,0	13	30
10	10	14	10,5	12,9	28	48	62	29	19,050	M10x1,5	37 500	29 000	0,5 - 1,5	13	55
12	12	16	12	15,4	32	54	70	33	22,225	M12x1,5	50 000	40 000	1,0 - 2,0	13	85
14	14	19	13,5	16,8	36	60	78	36	25,400	M14x1,5	67 000	48 000	1,5 - 3,0	15	125
16	16	21	15	19,3	42	66	87	40	28,575	M16x1,5	84 000	71 000	1,5 - 3,5	15	190
18	18	23	16,5	21,8	46	72	95	44	31,750	M18x1,5	103 000	86 000	2,0 - 5,0	15	265
20	20	25	18	24,3	50	78	103	47	34,925	M20x1,5	126 000	98 000	3,0 - 6,0	15	350
Tolerance	H7	0	0,2	--	--	--	--	1,0	--	DIN 13	--	--	--	--	--
±		0,12	0,2					0		6g					

*Safety factor C₀

In the case of rod ends, C₀ corresponds to the permissible load based on the weakest cross-section which results from the yield point of the outer material, with a safety factor of 1,2. The ultimate load is at least 1.5 the permissible C₀ load.

Further thread pitches on request.

100% cracking test of outer parts

Friction pairing steel on PTFE stainless steel fabric

All rod ends available with right-hand or left-hand thread

Outer part: 1.4057 (high-strength and rustproof)

Inner ring (ball): 1.4034 (rustproof)

Bushings: 1.4305 (rustproof)

Maintenance-free High-Performance spherical bearings

Series **SCHP..**

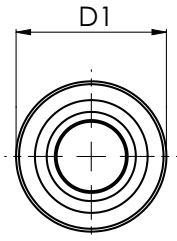
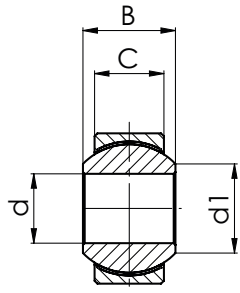

Angle of misalignment (AOM)

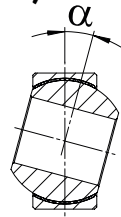

Friction pairing steel on PTFE-stainless steel fabric

Outer part: 1.4305 (rustproof)

Inner ring: 1.4034 (rustproof)

Maintenance-free High-Performance spherical bearings with V-groove

Series **SCHP.V**

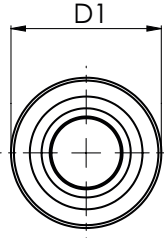
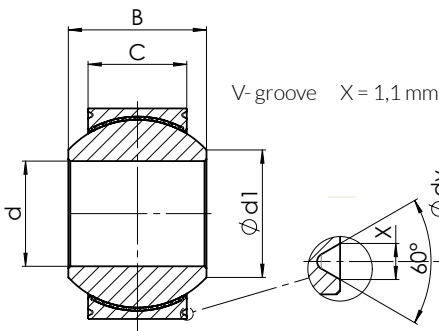

Angle of misalignment (AOM)

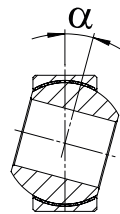

Friction pairing steel on PTFE stainless steel fabric

Outer part: 1.4305 (rustproof)

Inner ring: 1.4034 (rustproof)

Roll-in service on request

Type	d	D ₁	B	C	d ₁	d _v *	K Ball ø	Bearing capacities		Tilting moment Nm	AOM α°	Weight each ≈g
								dynamic C N	static C ₀ N			
6	6	16	9	6,75	8,9	14	12,700	15 000	23 000	0,025 - 0,16	13	10
8	8	19	12	9	10,4	17	15,875	25 000	40 000	0,1 - 0,33	13	15
10	10	22	14	10,5	12,9	20	19,050	37 500	58 000	0,25 - 0,5	13	25
12	12	26	16	12	15,4	24	22,225	50 000	79 000	0,5 - 0,66	13	55
14	14	29	19	13,5	16,8	27	25,400	67 000	105 000	0,75 - 1,0	15	70
16	16	32	21	15	19,3	30	28,575	84 000	130 000	0,75 - 1,2	15	85
18	18	35	23	16,5	21,8	33	31,750	103 000	161 000	1,0 - 1,66	15	100
20	20	40	25	18	24,3	38	34,925	126 000	193 000	1,5 - 2,0	15	160
Tolerance ±	H7	h6**	0 0,12	0 0,2	--	--	--	--	--	--	--	--

* Values only apply to V-groove

**recommended housing hole M7

Maintenance-free aluminum-titanium lightweight bearings

Series **SACA..IT**

Friction pairing: Titanium on PTFE- stainless steel fabric
 Outer part: high-tensile aluminum EN-AW 6082-T6
 Inner ring (ball): Titanium Ti-Al6-V4

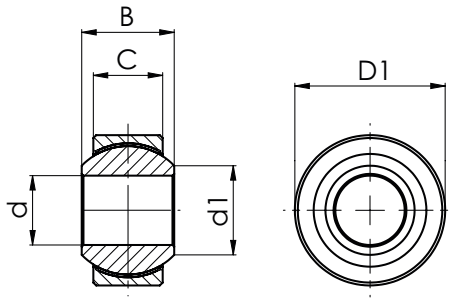

Angle of misalignment (AOM)

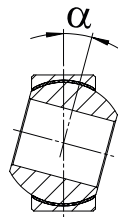

Series AL-TI..V as AL-TI.. but with V-groove

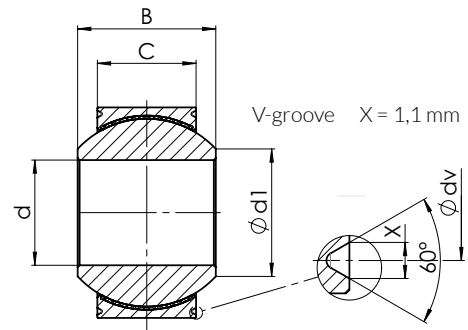

Type AL-TI..	d	d ₁	d _v (groove)	B	C	D ₁	K Ball Ø	Tilting moment	Bearing capacities		AOM	Weight
	mm	mm	mm	mm	mm	mm	mm	Nm	dynamic C N	static C ₀ N	α°	≈g
8	8	10,4	17	12	9	19,0	15,875	0,1 - 0,33	25 000	40 000	13	8
10	10	12,9	20	14	10,5	22,0	19,050	0,25 - 0,5	37 500	58 000	13	13
12	12	15,4	24	16	12	26,0	22,225	0,5 - 0,66	50 000	79 000	13	20
14	14	16,8	27	19	13,5	29,0	25,400	0,75 - 1,0	67 000	105 000	15	29
16	16	19,3	30	21	15	32,0	28,575	0,75 - 1,2	84 000	130 000	15	39
18	18	21,8	33	23	16,5	35,0	31,750	1,0 - 1,66	103 000	161 000	15	51
Tolerance	H7	--	--	-012	-0,20	h6	--	--	--	--	--	--

Further sizes and versions (with and without V-groove) on request, customized ball designs (dimensions B, d, d1) and customized outer parts (D1, C, d2) available.

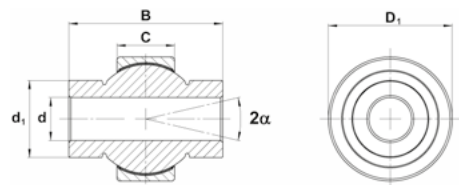

CARL HIRSCH MANN®

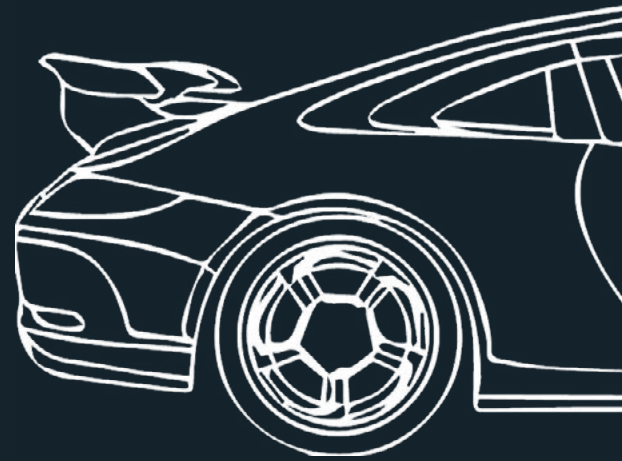
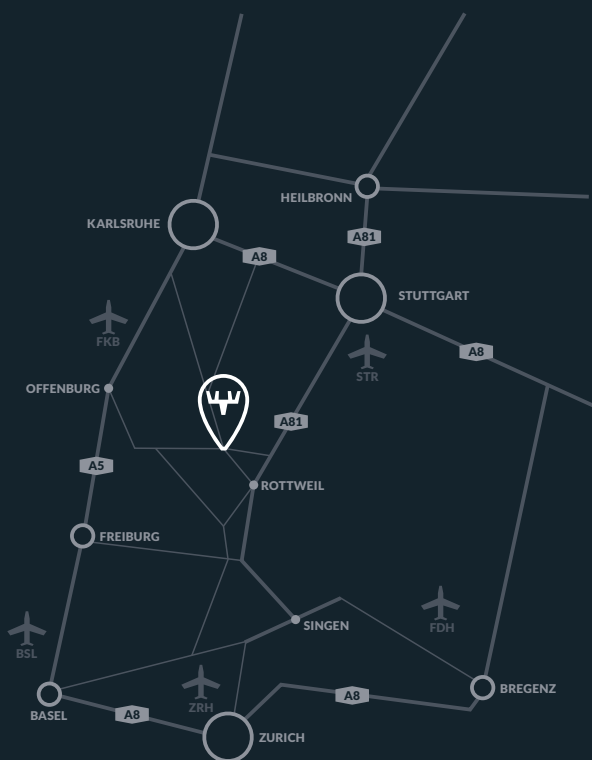

HEADQUARTER

Carl Hirschmann GmbH
Kirchentannenstraße 9
78737 Fluorn-Winzeln
Germany

T +49 7402 183-0
F +49 7402 183-10
E info@carlhirschmann.de

USA

Carl Hirschmann, Inc.
165 East Commerce Drive
Ste 104
Schaumburg, IL 60173, USA

T +1 847 468 9700
F +1 847 468 9701
E info@carlhirschmann.us

CHINA

Carl Hirschmann
Room C528, Block 180,
South Chang Jiang Road
Bao Shan District, Shanghai
P.R. CHINA 200433

T +86 139 16 13 58 45
E info@carlhirschmann.com.cn

carlhirschmann.de