

TOMAR



EMERGENCY VEHICLE PRODUCTS

TOMAR Electronics, Inc.

TABLE OF CONTENTS

Lightbars	
970L Scorpion Lightbar.....	2
975L Scorpion Halfbar.....	3
Spider Lightbar Series	4 - 5
Scorpion Beacon & R 13/14 Microbar.....	6 - 7
LED Series Lighthoods	
R13 & R14 L-Sticks.....	8
200 Series Traffic Directors & Warning Systems.....	9
RECT-13LS.....	10 - 11
RECT-14LS.....	12 - 13
RECT-16LS/V.....	14 - 15
RECT-25 iLED Series.....	16 - 17
200S-2 iLED Series.....	18 - 19
iLED Series.....	20 - 21
iLED Brackets.....	22
UC-LED.....	23
RECT-34L Series.....	24 - 25
RECT-37L Series.....	26 - 27
RECT-46L Series.....	28 - 29
RECT-79L Series.....	30 - 31
PAR-36L Series.....	32 - 33
Self-contained Strobe Systems	
RECT25-W & 200S-BRW windshield mounted systems.....	34 - 35
T-LED.....	36 - 37
4620N.....	38 - 39
Lighthoods	
RECT-34 Series.....	40 - 41
RECT-37 Series.....	42 - 43
RECT-46 Series.....	44 - 45
RECT-79 Series.....	46 - 47
PAR-36.....	48 - 49
470, 700, 490, 495, 800, 801 Remote Lighthoods.....	50 - 51
Mounting Bezels.....	52 - 53
Scene Lights	54 - 55
Power Supplies	
770 Series.....	56 - 57
780 Series.....	58 - 59
400-1228/401-1228, Cable kits.....	60 - 61
Strobe and LED Systems	
770C, 780C Undercover Systems.....	62 - 63
400 Series Strobe Systems.....	64 - 65
LED-AMBSYS-01, AMBSYS-04, AMBSYS-05.....	66 - 67
NFPA Systems	68 - 69
Strobe Beacons	
Micro IV.....	70 - 71
824 Multi-Strobe.....	72 - 73
Controllers and Sirens	
948 Digital Digital Control Panel.....	74
940 Digital Digital Control Panel.....	75
940 Siren Amplifier.....	76
943 Digital Switch Box.....	77
DRV100 & SPK100.....	78 - 79
SPK200 & SPK300.....	80 - 81
Sales Offices	82
Warranty	inside back cover

THE 970L SCORPION™ LIGHTBAR

Low-Profile Lightbar Series



TOMAR's 970L Scorpion™ lightbar maintains the rugged structure of Tomar's 930/950 series lightbars but with an efficient low profile modern look and optimized led and optics design. With extruded aluminum housing, cast aluminum end caps, and easily replaceable, hermetically sealed optical Lexan light modules the 970L lightbar is built to last. The 970L lightbar includes many scalable and interchangeable features such as 3 or 6 LED front and rear warning modules, 6 or 12 LED corner modules and your choice of halogen or LED take down and alley lights. With this much versatility you are sure to find a configuration that meets your budget and performance needs.

- Easy to maintain hermetically sealed lamp modules.
- Potted controller and waterproof wiring standard.
- 3 or 6 LED versions front/rear, 6 or 12 LED corners
- 70 watt halogen, 140 watt halogen or High intensity LED take downs
- Fully programmable flash patterns via wires or 940L-DCP, digital version available.
- Integrated 6 or 8 element traffic director standard on all full size bars.
- Optional on-board traffic preemption emitter.
- Available in 21", 26", 35", 44", 49", 53", 58" and 67" lengths
- STT lights available on 49" and larger bars.
- ICC lights available all length bars.



Approvals: SAE J595 & J845, CCR Title 13, SAEJ2498, NFPA Configurations available

THE 975L SCORPION™ HALFBAR

Low-Profile Lightbar Series



TOMAR's 975L Scorpion™ lightbar maintains the rugged structure of Tomar's previous line of lightbars but with a low profile modern look. With an extruded aluminum housing and optical Lexan light modules the 975L lightbar is built to last. The 975L lightbar includes many scalable features such as 3 or 6 LED front warning modules, 3 LED corner modules and your choice of LED scene lights. With this much versatility you are sure to find a configuration that meets your budget and performance needs.

- Easy maintenance and lamp replacement
- Hermetically sealed lamp modules
- Potted controller and waterproof wiring
- Lamp modules available in 3 or 6 LED versions
- Available corner modules
- Available in 16", 21", 26", 30", 40", 44", 48", 53", 62", 67", and 75" lengths
- Integrated 6 or 8 element traffic director standard on all 6 lamp or longer bars.
- LED scene lights or 13° down angle lights available
- 48 programmable flash patterns
- Optional traffic preemption emitter
- STT lights available on 49" and larger bars
- ICC lights available all length bars
- Approvals: J595, SAEJ2498, CCR Title 13, NFPA Configurations available





SPIDER Interior Lightbars



- Anodized aluminum housing for durability
- Extra low profile for improved visibility
- Easy no drilling required installation with vehicle specific mounting kit
- Vehicle specific shroud prevents light from reflecting back into the driver's eyes
- Extra low profile for improved visibility
- Ten Low profile 6-LED lamps
- Meets SAE-J595 Class 1, SAE-J845 Class 1, CA Title 13
- Five-year warranty on LEDs and controller

The Spider High Intensity, low profile, interior LED lightbar is a full featured bar with the light output of a full sized exterior lightbar. Designed to mount in the upper front windshield or rear deck and customized for all popular emergency response vehicles the low profile design is perfect for undercover and slick top vehicles. The lower shroud fits snugly along the contour of the windshield to prevent flashback while the upper part of the housing fits the contour of the headliner. Eight 6 LED forward facing lamp modules, two 45° intersection clearing modules plus two, adjustable angle, flashing takedown modules insure optimum light output even through heavy window tint.

The Spider Interior Lightbar has versions to fit the Taurus, Explorer, F150/250, Caprice, Impala, Tahoe, Silverado, and Charger.

Specifications

Item	Description
Electrical	12-24 VDC,
Amp Draw	4.3 Amps max.

SPIDER Rear SUV Lightbar



- Easy to install, integrates seamlessly with vehicles rear spoiler
- Easy maintenance and lamp replacement
- Hermetically sealed lamp modules
- Potted controller and waterproof wiring standard
- Single and Dual color versions available
- Integrated traffic direction feature standard
- Meets SAE-J595, SAE-J845, CA Title 13
- ECE 65 approved versions available
- 5 year warranty

The Spider Rear SUV lightbar is a warning light system that seamlessly integrates the power of a lightbar into the rear body of an SUV. The Spider Rear SUV lightbar is uniquely designed to conform to the contour of police SUV's and provide the most effective light output available without compromising rear window visibility

Specifications

Item	Description
Current Draw	2.4A Typ.Per Vehicle
Operating Temperature	-55°C - +65°C
Input Voltage	12 VDC

SCORPION™ Beacon



- SAE Class 1, all colors
- Waterproof design
- Single or dual color lamps
- 1/2 inch female pipe mount
- Optional cigar plug and magnet mount (some models)
- Available in aluminum or black
- 5 year warranty

TOMAR's Scorpion™ Beacon has an all aluminum housing, and utilizes the corner lamps of our Scorpion Lightbar. The Scorpion™ Beacon is available with single or dual colored LED modules. The Scorpion™ Beacon comes standard 1/2 inch female pipe mount and a 10 foot power cable. A cigar plug and mag mount version is also available.

Specifications

Item	Description
Electrical	12 VDC, 2.1 amps operation
Operating Temperature	-40°C - +65°C

Ordering Information

Item	Description
BCN-CR1	360° Beacon
BCN-CR1B	360° Beacon, black housing
BCN-CR1-CP/MAG	360° Beacon, cigar plug/mag mount
BCN-CR1B-CP/MAG	360° Beacon, cigar plug/mag mount, black housing

Item	Description
BCN-CR2	360° Dual Color Beacon
BCN-CR2B	360° Dual Color Beacon, black housing
BCN-CR2-MAG	360° Dual Color Beacon, mag mount
BCN-CR2B-MAG	360° Dual Color Beacon, mag mount, black housing

R 13/14 Microbar

Mini LED Lightbar



- ultra-high intensity LEDs
- LED's available in amber, blue, red and white
- easy, two screw lamp replacement
- built in flasher with multiple user selectable flash patterns
- black powder coated housing

The R 13/14 Microbar is designed for ultra-durability and easy maintenance using a powder coated metal housing and six of TOMAR's RECT-13 or RECT-14, ultra-high intensity lamp modules. The all-weather waterproof design includes not only hermetically sealed lamps but a waterproof internal control module as well as waterproof harness connections making it suitable for all mounting locations.

The R 13/14 Microbar features six warning modes, user selectable flash patterns and a dim feature for nighttime operation. Available options include magnetic mounting system, cigar plug connectivity with two switch operation and 20', 30' or 40' cable lengths.

Specifications

Item	Description
Dimensions (excluding feet)	13.25" wide x 1.5" tall x 8.5" deep
Current Draw	R13 version 1.2A avg. R14 version 1.6A avg.
Operating Temperature	-55°C - +65°C
Input Voltage	12 VDC

LED SERIES LIGHTHEADS

R13 & R14 L-Sticks

Mini LED Lightsticks



- easy, two screw lamp replacement
- built in flasher with multiple user selectable flash patterns
- internal/external mounting
- LED's available in amber, blue, red and white
- available in polished aluminum or black housing

Specifications

Item	Description
R13 & R14 dimensions	1.75" high x 1.75" deep x length = (see below)
R13 L-Stick lengths	12 lamp modules = 47.25" 10 lamp modules = 39.75" 8 lamp modules = 32" 6 lamp modules = 24.5" 4 lamp modules = 17" 2 lamp modules = 9.25"
R14 L-Stick lengths	12 lamp modules = 57 " 10 lamp modules = 47.75" 8 lamp modules = 38.5" 6 lamp modules = 29.25" 4 lamp modules = 20" 2 lamp modules = 11 "
Operating Temperature Range	-55°C to +65°C
Current Draw	200 mA average per R13 module in Neobe flash pattern 265 mA average per R14 module in Neobe flash pattern
Operating Temperature	-55°C - +65°C

The L-Stick is the ideal choice for a primary Warning device to clear traffic, a Traffic Director to provide visual indication for traffic movement, or a single unit that does both.

The L-Stick's programmable internal controller features 3 unique programmable warning modes, left, right and center out programmable arrow functions as well as a dim feature for nighttime use.

Both the Traffic Director and the Warning versions can be configured with either RECT-13 or RECT-14 style LED lamp heads. Both configurations are available in a variety of lengths to fit your space requirements. The R13 & R14 L-Sticks come in 2 or 4 lamp module warning lights and 6, 8, 10, and 12 lamp module warning & arrow lights.

The L-Sticks are also designed for easy maintenance using TOMAR's mini RECT-13 or RECT-14, ultra-high intensity lamp modules for easy replacement. The L-Stick series is designed to deliver unparalleled performance in any weather condition. The all weather waterproof design, includes hermetically sealed lamps, a potted internal control module as well as waterproof harness connections making it equally suitable for all mounting locations either inside or outside of the vehicle.

The included L shaped mounting brackets make installation simple. Designed to fit above the vehicle CHMSL light or flush to the deck these brackets offer the flexibility to mount the L-Stick almost anywhere.

200 Series Traffic Directors & Warning Systems

Low-Profile LED Lightheads

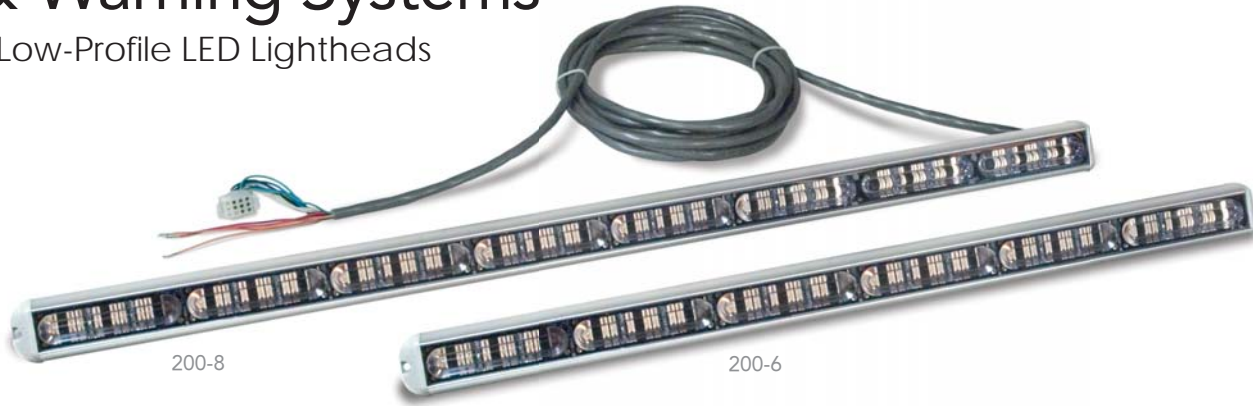

- high efficiency TIR technology
- standard flange or optional rail mount
- internal/external mounting
- super-wide angle for superior off-axis visibility
- available in amber, blue, red and white
- available in polished aluminum or black housing

The 200 Series Traffic Directors & Warning Systems are designed with the latest LED technology, and provide a sleek low-profile look with extreme light output. Our latest LED designs are based on TIR (Total Internal Reflection) technology and provide unprecedented off-center visibility and a unique thermal management system that utilizes the 200's entire housing to draw heat away from the LEDs for longer life and more consistent light output.

Ordering Information

NOTE: The models listed below are for use with the 200-SYS-8 or 200-SYS-6 flasher system (supplied separately) or a 3rd party - ground activated flasher. Available clear lens LED colors are amber, blue, red and white. High power, standard power and low current modules available.

Model	Description
200-6	Aluminum finish, standard flange mount
200-R-6	Aluminum finish, rail mount
200-B-6	Black finish, standard flange mount
200-RB-6	Black finish, rail mount
200-8	Aluminum finish, standard flange mount
200-R-8	Aluminum finish, rail mount
200-B-8	Black finish, standard flange mount
200-RB-8	Black finish, rail mount



Optional 200-SYS-6 or 200-SYS-8 flasher

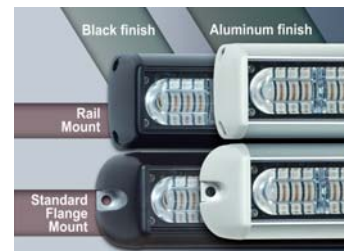

Specifications

Item	Description
200-6 Size (standard mount)	29.25" wide x 1.97" high x 1.36" deep (743mm x 50mm x 34.5mm)
200-6 Size (rail mount)	28.55" wide x 1.97" high x 1.36" deep (725.2mm x 50mm x 34.5mm)
200-8 Size (standard mount)	38.45" wide x 1.97" high x 1.36" deep (976.6mm x 50mm x 34.5mm)
200-8 Size (rail mount)	37.75" wide x 1.97" high x 1.36" deep (958.9mm x 50mm x 34.5mm)
Current Draw (per element) - in Single Flash 75 FPM Mode @ 12VDC	High power: 0.9A avg. Standard power: 0.7A avg. Low current: 0.45A avg.
Operating Temperature	-55°C - +65°C

RECT-13LS mini LED warning light

LED Lighthouse with Programmable Flasher



TOMAR's RECT-13LS is an ultra mini, ultra high intensity, LED warning light with huge punch. Made of optical Lexan and hermetically sealed, this one piece, fit anywhere design makes installation a breeze. At only 3.75" x 1.2" x .70" the RECT-13LS is one of the smallest warning lights on the market to meet SAE J845, SAE J595 and CAL Title 13 specifications.

- 3 ultra-high intensity LEDs
- Multiple user selectable flash patterns
- internal/external mounting
- Full array of mounting bracket options
- Meets SAE J845, SAE J595, CAL Title 13
- Available in red, blue, amber, green and white LEDs
- 5 year warranty

The RECT-13LS's compact size makes it the perfect auxiliary light for all the hard to fit locations. Mount directly to the body, the rearview mirror, grille or the license plate. A complete line of brackets means you can mount this light practically anywhere.



RECT-13LS MINI LED WARNING LIGHT



Specifications

Item	Description
Size	3.75" Wide x 1.2" High x .70" Deep
Current Draw	.45 Amp avg.
Input Voltage	12VDC
Operating Temperature	-55°C - +65°C

Mounting Brackets



RECT-14LS dual channel mini LED warning light

LED Lighthouse with Programmable Flasher



- 4 ultra-high intensity LEDs
- Available in single or dual colors
- Multiple user selectable flash patterns
- internal/external mounting
- Full array of mounting bracket options
- Meets SAE J845, SAE J595, CAL Title 13
- Available in red, blue, amber, green and white LEDs
- 5 year warranty

TOMAR's RECT-14LS dual channel, ultra high intensity, LED warning light delivers a huge impact in a small footprint. Dual channels offer independent function of up to two lamp colors with dozens of user-selectable modes.

Made of optical Lexan and hermetically sealed, this one piece, fit anywhere design makes installation a breeze. At only 4.5" x 1.25" x .75" the RECT-14LS is one of the smallest warning lights on the market to meet SAE J845, SAE J595 and CAL Title 13 specifications.

The RECT-14LS's compact size makes it the perfect auxiliary light for all the hard to fit locations. Mount directly to the body, the rearview mirror, grille or the license plate. A complete line of brackets means you can mount this light practically anywhere.

RECT-14LS MINI LED WARNING LIGHT

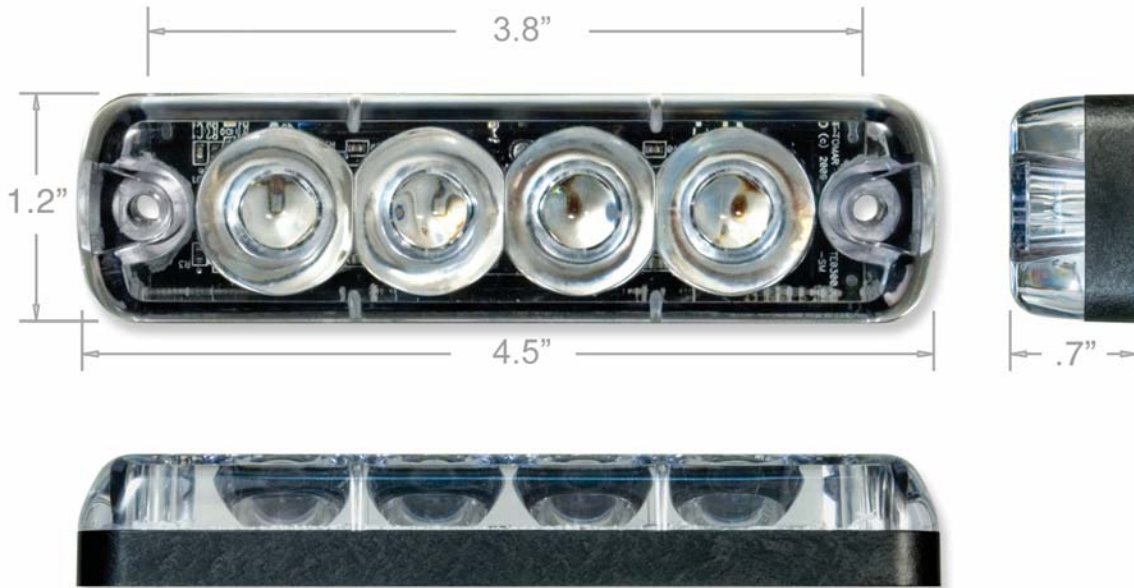

Specifications

Item	Description
Size	4.5" Wide x 1.2" High x .7" Deep
Current Draw	.4 Amp avg.
Input Voltage	12VDC
Operating Temperature	-55°C - +65°C

Mounting Brackets



RECT-16 dual channel mini LED warning light

LED Lighthead with Programmable Flasher



- 6 ultra-high intensity LEDs
- Available in single or dual colors
- Multiple user selectable flash patterns
- internal/external mounting
- Full array of mounting bracket options
- Meets SAE J845, SAE J595, CAL Title 13
- Available in red, blue, amber, green and white LEDs
- Optics for horizontal or vertical mounting
- 5 year warranty

TOMAR's RECT-16 dual channel, ultra high intensity, LED warning light delivers a huge impact in a small footprint. Dual channels offer independent function of up to two lamp colors with dozens of user-selectable modes.

The RECT-16 is made with optical Lexan and hermetically sealed into a one piece design for easy installation. The RECT-16 has optics that are designed to optimize the light spread for either horizontal mounting (RECT-16LS version) or vertical mounting (RECT-16LSV version). The RECT-16 also meets SAE J845, SAE J595 and CAL Title 13 specifications.

The RECT-16's compact size makes it the perfect auxiliary light for all the hard to fit locations. Mount directly to the body, the rearview mirror, grille or the license plate. A complete line of brackets means you can mount this light practically anywhere.

RECT-16 MINI LED WARNING LIGHT



Specifications

Item	Description
Size	6.125" Wide x 1.2" High x .7" Deep
Current Draw	.4 Amp avg.
Input Voltage	12/24VDC
Operating Temperature	-55°C - +65°C

Mounting Brackets





RECT-25 Low-Profile Series

LED Lighthead with Programmable Flasher



- high efficiency TIR technology
- standard flange or optional rail mount
- internal/external mounting
- super-wide angle for superior off-axis visibility
- 11 different flash rates
- available in amber, blue, red and white
- 5 year warranty

The iLED™ RECT-25 is the first of TOMAR's new Low-Profile series. Designed using the latest in LED technology, the RECT-25 is unsurpassed in brightness and light distribution. The RECT-25 is available in High Power, Standard Power and Low Current configurations and has 11 different flash rates. Standard flange mounting or optional rail mounting is available.



RECT25LSHPB



RECT25 LOW-PROFILE LED LIGHTHEAD

Standard Flange Mount

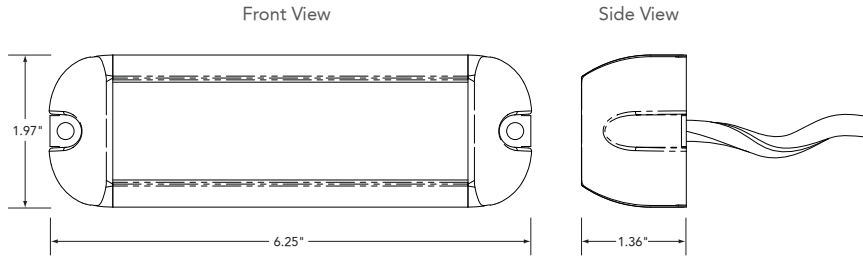

Rail Mount

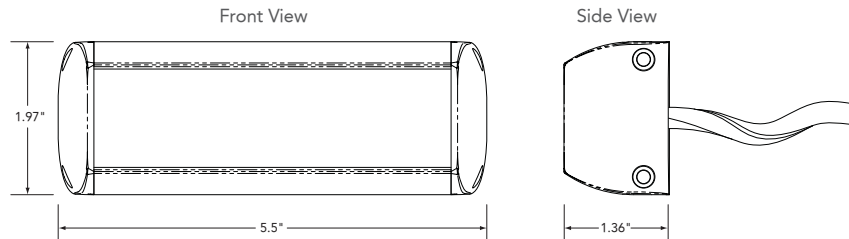

Ordering Information

Please specify lens colors and model number when ordering. Available clear lens LED colors are amber, blue, red and white. Colored lenses available in amber, blue and red.

Aluminum Finish	Black Finish	
Model No.	Model No.	Description
RECT25LSHP	RECT25LSHPB	12-LED High power iLED™, clear lens, standard flange mount
RECT25LSSD	RECT25LSSDB	9-LED Standard power iLED™, clear lens, standard flange mount
RECT25LSLC	RECT25LSLCB	6-LED Low current iLED™, clear lens, standard flange mount
RECT25CLSHP	RECT25CLSHPB	12-LED High power iLED™, colored lens, standard flange mount
RECT25CLSSD	RECT25CLSSDB	9-LED Standard power iLED™, colored lens, standard flange mount
RECT25CLSLC	RECT25CLSLCB	6-LED Low current iLED™, colored lens, standard flange mount
RECT25LSRHP	RECT25LSRHPB	12-LED High power iLED™, clear lens, rail mount
RECT25LSRSD	RECT25LSRSDB	9-LED Standard power iLED™, clear lens, rail mount
RECT25LSRLC	RECT25LSRLCB	6-LED Low current iLED™, clear lens, rail mount
RECT25CLSRHP	RECT25CLSRHPB	12-LED High power iLED™, colored lens, rail mount
RECT25CLSRSD	RECT25CLSRSDB	9-LED Standard power iLED™, colored lens, rail mount
RECT25CLSLC	RECT25CLSLCB	6-LED Low current iLED™, colored lens, rail mount

Specifications

Item	Description
Size (standard mount)	6.25" wide x 1.97" high x 1.36" deep (158.8mm x 50mm x 34.5mm)
Size (rail mount)	5.5" wide x 1.97" high x 1.36" deep (139.7mm x 50mm x 34.5mm)
Current Draw	High power: 1.6A avg. Standard power: 1.2A avg. Low current: 0.8A avg.
Operating Temperature	-55°C - +65°C

LED SERIES LIGHTHEADS



200S-2 Low-Profile Series

LED Lighthead with Programmable Flasher



200S-B-2

Designed with the latest LED technology, the TOMAR 200S Series provides a sleek low-profile look with extreme light output. Our latest LED designs are based on TIR (Total Internal Reflection) technology and provide unprecedented off-center visibility and a unique thermal management system that utilizes the 200S' entire housing to draw heat away from the LEDs for longer life and more consistent light output.

- high efficiency TIR technology
- standard flange or optional rail mount
- internal/external mounting
- super-wide angle for superior off-axis visibility
- 10 different flash rates
- available in amber, blue, red and white
- available in polished aluminum or black housing
- 5 year warranty

Selectable Flash Patterns (Individual Lamp Flash Rates)
(Phase 0 and Phase 1 alternate)

1. Neobe 150 FPM (Factory Setting)
2. Neobe 75 FPM
3. Double flash 250 FPM
4. Double flash 125 FPM
5. Single flash 375 FPM
6. Single flash 150 FPM
7. Single flash 75 FPM
8. Multi flash 1 (Rate 1, 3, 5, 1)
9. Multi flash 2 (Rate 2, 4, 6, 7)
10. Demo Mode (Sequences all rates)

Standard Flange Mount back



Rail Mount back



200S-2 SERIES LOW-PROFILE LIGHTHEADS

Standard Flange Mount

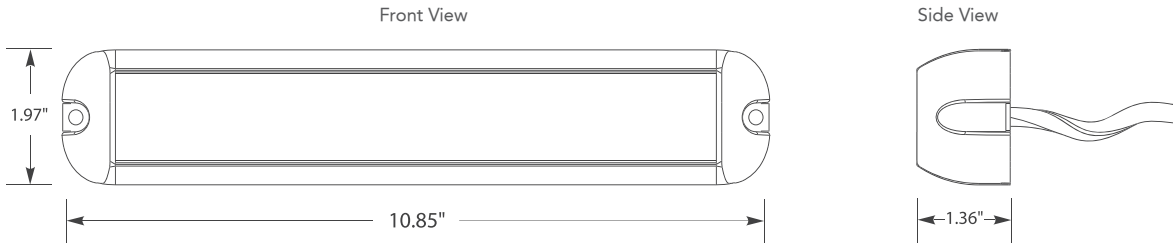

Rail Mount

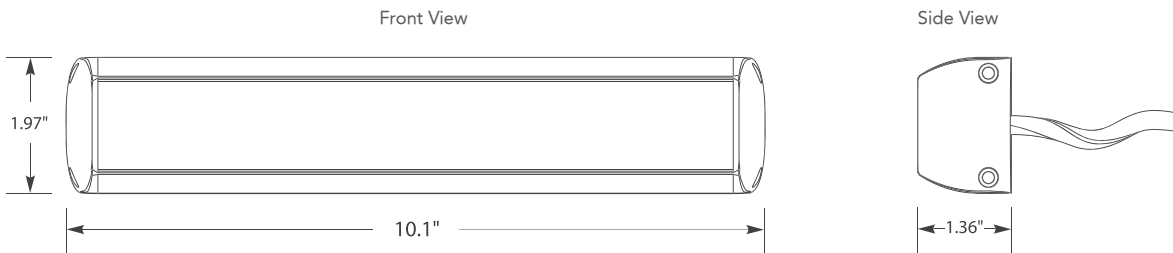

Ordering Information

Available clear lens LED colors are amber, blue, red and white. High power, standard power and low current modules available.

Model	Description
200S-2	Aluminum finish, standard flange mount
200S-R-2	Aluminum finish, rail mount
200S-B-2	Black finish, standard flange mount
200S-BR-2	Black finish, rail mount

Specifications

Item	Description
Size (standard mount)	10.85" wide x 1.97" high x 1.36" deep (275.6mm x 50mm x 34.5mm)
Size (rail mount)	10.1" wide x 1.97" high x 1.36" deep (257.8mm x 50mm x 34.5mm)
Current Draw - in Single Flash 75 FPM Mode @ 12VDC	High power: 1.8A avg. Standard power: 1.4A avg. Low current: 0.9A avg.
Operating Temperature	-55°C - +65°C

LED SERIES LIGHTHEADS



iLED™

Intelligent LED Series



RECT-46LWS, RECT-34LWS, RECT-79LWS, PAR-36LWS, RECT-37LWS

- ultra-high intensity LED's
- wide angle optical lens
- synchronizable
- programmable flash patterns
- available in many color configurations

The TOMAR iLED™ features a built-in single or dual element LED flasher lamp head, creating a completely self-contained warning lamp unit. The iLED™ series features up to 32 user programmable flash patterns, synchronization control, and is available in many different lamp colors and configurations.

The iLED™ can easily be linked and synchronized to flash simultaneously with other iLEDs. The iLED™ uses TOMAR's wide angle optics, which give a full intensity beam at ± 45 horizontal degrees off axis, making the TOMAR LED the widest angle light in the marketplace! Meets or exceeds SAE J845 and SAE J1889.

Specifications

Item	Model	Description
Voltage	All	12 thru 28VDC
Current Draw	RECT-34 & PAR-36:	0.4A – 0.2A (steady burn), 0.2A – 0.1A (flashing)
	RECT-37 & 46	0.8A – 0.4A (steady burn), 0.4A – 0.2A (flashing)
	RECT-79	1.6A – 0.8A (steady burn), 0.8A – 0.4A (flashing)
Size and Weight	PAR-36	4.5" diameter, 1.5" deep (114.3mm, 38mm)
	RECT-34	4.25" wide x 3.0" high x 1.75" deep (107.9mm x 76.2mm x 44.4mm)
	RECT-37	7.25" wide x 3.0" high x 1.125" deep (184.2mm x 76.2mm x 28.6mm)
	RECT-46	6.55" wide x 4.16" high x 1.125" deep (166.4mm x 105.7mm x 28.6mm)
	RECT-79	9.125" wide x 7.125" high x 1.125" deep (231.8mm x 181.0mm x 28.6mm)

Ordering Information

Model No.	Description
PAR-36LWS	Clear lens, single LED color, single flashing
PAR-36CLWS	Color lens, single LED color, single flashing
RECT-34LWS	Clear lens, single LED color, single flashing
RECT-34CLWS	Color lens, single LED color, single flashing
RECT-37LLWS	Clear lens, single or dual LED color, dual flashing (left/right)
RECT-37LLVWS	Clear lens, single or dual LED color, dual flashing (top/bottom)
RECT-37CLLWS	Color lens, single LED color, dual flashing (left/right)
RECT-37CLLWWS	Color lens, single LED color, dual flashing (top/bottom)
RECT-46LLWS	Clear lens, single or dual LED color, dual flashing (left/right)
RECT-46LLVWS	Clear lens, single or dual LED color, dual flashing (top/bottom)
RECT-46CLLWS	Color lens, single LED color, dual flashing (left/right)
RECT-46CLLWWS	Color lens, single LED color, dual flashing (top/bottom)
RECT-79LLWS	Clear lens, single or dual LED color, dual flashing (left/right)
RECT-79LLVWS	Clear lens, single or dual LED color, dual flashing (top/bottom)
RECT-79CLLWS	Color lens, single LED color, dual flashing (left/right)
RECT-79CLLWWS	Color lens, single LED color, dual flashing (top/bottom)

iLED Lamp Configurations and Available Colors

Model No.	Color	
LWS	A	B G R W
PAR-36		
RECT-34		
CLWS	A	B G R
PAR-36		
RECT-34		
LLWS & LLVWS	AA AB AR AW	BB BW GG RB RR RW WW
RECT-37		
RECT-46		
RECT-79		
CLLWS & CLLVWS	AA	BB GG RR
RECT-37		
RECT-46		
RECT-79		

Ordering Example



LED SERIES LIGHTHEADS

iLED™ Brackets

Brackets for RECT-37L, RECT-46L,
RECT-25 LED Lightheads



ILED37/46 BRKT
RECT-37/46L No-drill Bracket

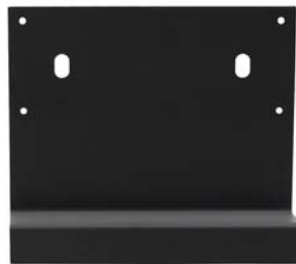

ILED 5.5" BRKT
RECT-37L 5.5" No-drill Bracket



RECT-37L U-Mount



RECT-25 U-Mount

Ordering Information

Available clear lens LED colors are amber, blue, red and white. High power, standard power and low current modules available.

Model	Description
ILED 3.5" BRKT	No-drill bracket for iLED™ RECT-37L model.
ILED37/46 BRKT	No-drill bracket for iLED™ RECT-37L and RECT-46L models.
ILED 5.5" BRKT	No-drill bracket for iLED™ RECT-37L model.
RECT-37L-UMOUNT	RECT-37 LED Mounting Plate/Bracket
RECT-25L-UMOUNT	RECT-25 LED Mounting Plate/Bracket

Specifications

Model	Dimensions
ILED 3.5" BRKT	7.38" wide x 4.44" high x 1.3" deep (187.5mm x 112.8mm x 33mm)
ILED37/46 BRKT	7.38" wide x 4.7" high x 2.0" deep (187.5mm x 119.4mm x 50.8mm)
ILED 5.5" BRKT	7.38" wide x 6.44" high x 1.3" deep (187.5mm x 163.6 x 33mm) 7.44" wide x 2.75" high x 2.63" deep (189mm x 69.9 x 66.8mm)
RECT-25L-UMOUNT	4.2" wide x 2.5" high x 1.2" deep (106.7mm x 63.5 x 30.5mm)



- Ultra-high intensity LED
- Multiple user selectable flash patterns
- Available in red, blue, amber and white LEDs
- Four different beam patterns available
- 5 year warranty

UC-LED

Undercover Insert LED Flasher

TOMAR's Concealed LEDs provide the ultimate warning light performance for low-profile and unmarked emergency vehicles. The compact LED lamp assembly is custom mounted inside new style headlight and taillight composite housings. The Concealed System features a high intensity LED lamp and a waterproof in-line control module. Each module is independently controllable, features multiple flash patterns, two modes of operation including dimming feature, synchronizable with up to 10 other light modules.



Ordering Information

Item	Dimensions
UC-LED-X*	Undercover insert
UC-LED20-X*	Undercover insert with 20° beam pattern
UC-LED80-X*	Undercover insert with 80° beam pattern
UC-LED360-X*	Undercover insert with 360° beam pattern

*X=LED color Amber=A Blue=B Red=R White=W

Specifications

Item	Dimensions
UC-LED dimensions	1.5" Dia x .5" flange - .45" optic (1" hole)
UC-LED20 dimensions	1.5" Dia x .5" flange - .50" optic (1" hole)
UC-LED80 dimensions	1.5" Dia x .5" flange - .30" optic (1" hole)
UC-LED360 dimensions	1.5" Dia x .5" flange - 1" optic (1" hole)
Input Current	.5 a / 12Vdc .3 a / 24Vdc
Input Voltage Range	12/24 VDC.
Operating Temperature	-40°C to +85°C

LED SERIES LIGHTHEADS



RECT-34L Series 3" x 4" LED Rectangular Lamps

- ultra-high intensity LED's
- wide angle optical lens
- fits all popular emergency vehicles
- five year warranty
- available in five lens colors

The RECT-34L LED lamp family features ultra-high intensity LED's and has a new optical wide angle lens. The lamps are designed for 12–28 VDC operation and have potted electronics for the ultimate in reliability. Expected life is 100,000 hours. Warranty is five years from date of purchase. The lamps come complete with mounting hardware, WP connector with 12" leads or integrated 12" leads. The RECT-34L series is designed to fit any TOMAR 3" x 4" mounting bezel. Meets SAE J845 and SAE J1889.

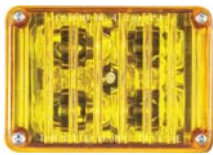

Amber

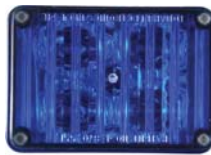

Blue



Clear



Green



Red

Ordering Information







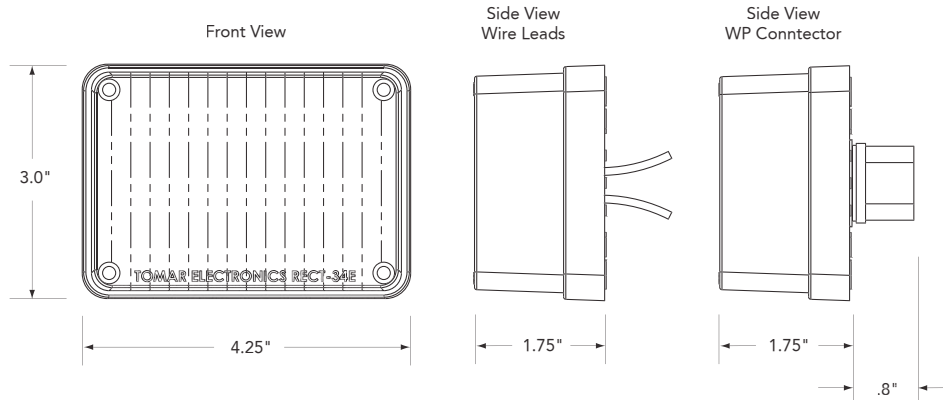

Please specify lens colors and model number when ordering. Available colors are Amber, Blue, Clear, Green and Red.

Model No.	Description
RECT-34L	LED, 3" x 4" rectangular lamp, clear lens, WP connector
RECT-34CL	LED, 3" x 4" rectangular lamp, colored lens, WP connector
RECT-34LW	LED, 3" x 4" rectangular lamp, clear lens, wire leads (no connector)
RECT-34CLW	LED, 3" x 4" rectangular lamp, colored lens, wire leads (no connector)

RECT-34L SERIES LIGHTHEADS



RECT-34L Lamp Configurations and Available Colors

WP Connector	Wire Leads	Color				
CL	CLW	 A	 B	 G	 R	
L	LW	 B	 B	 G	 R	 W

Ordering Example

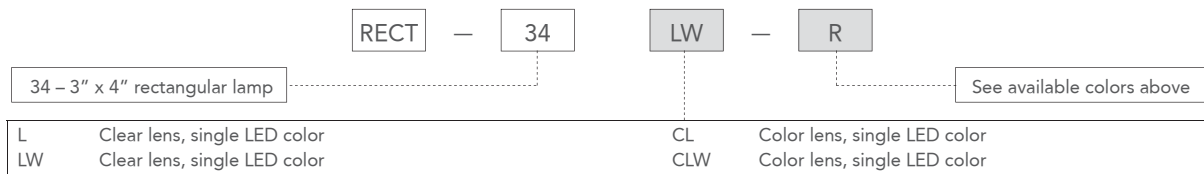

Specifications

Item	Description
Voltage	10 thru 30VDC
Current Draw	0.45A @ 12VDC 0.225A @ 28VDC
Warranty	Extended 5 year warranty

LED SERIES LIGHTHEADS



RECT-37L Series

3" x 7" LED Rectangular Lamps

- ultra-high intensity LED's
- wide angle optical lens
- fits all popular emergency vehicles
- five year warranty
- available in many color configurations

The RECT-37L LED lamp family features ultra-high intensity LED's and has a new optical wide angle lens designed to meet the latest KKK ambulance specifications. The lamps are designed for 12-28 VDC operation and have potted electronics for the ultimate in reliability. Expected life is 100,000 hours. Warranty is five years from date of purchase. The lamps come complete with mounting hardware, WP connector with 12" leads or integrated 12" leads. The RECT-37L series is designed to fit all TOMAR 3" x 7" mounting bezel. The RECT-37L uses TOMAR's wide angle optics, which give a full intensity beam at ± 45 horizontal degrees off axis, making the TOMAR LED the widest angle light in the marketplace! Meets SAE J845 and SAE J1889.



Amber

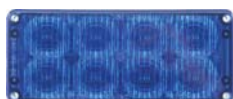

Blue



Clear

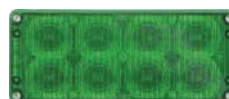

Green



Red

Ordering Information







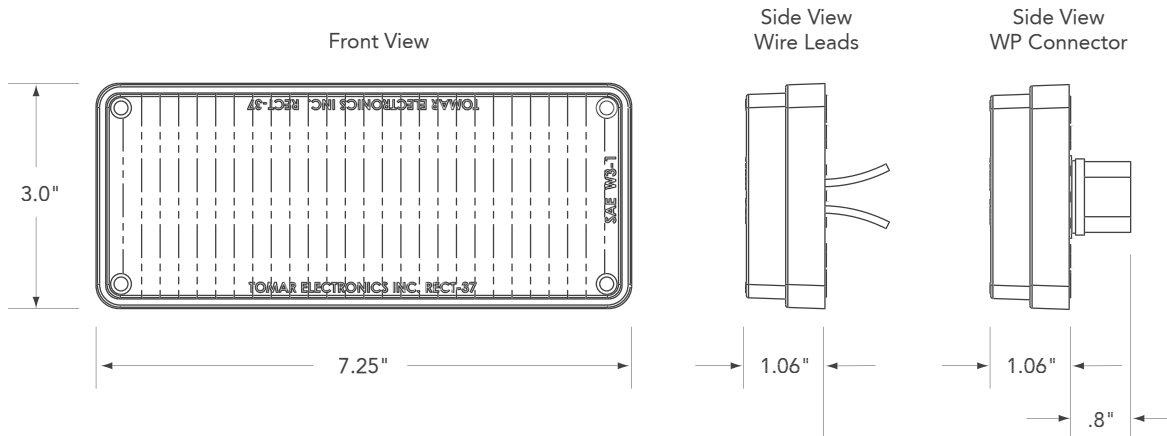































Please specify lens colors and model number when ordering. Available colors are Amber, Blue, Clear, Green and Red.

Model No.	Description
RECT-37L	Clear lens, single LED color, single flashing
RECT-37LL	Clear lens, single or dual LED color, dual flashing (left/right)
RECT-37LLV	Clear lens, single or dual LED color, dual flashing (top/bottom)
RECT-37CL	Color lens, single LED color, single flashing
RECT-37CLL	Color lens, single LED color, dual flashing (left/right)
RECT-37CLLV	Color lens, single LED color, dual flashing (top/bottom)
RECT-37LW	Clear lens, single LED color, single flashing, wire lead
RECT-37LLW	Clear lens, single or dual LED color, dual flashing (left/right), wire lead
RECT-37LLWV	Clear lens, single or dual LED color, dual flashing (top/bottom), wire lead
RECT-37CLW	Color lens, single LED color, single flashing, wire lead
RECT-37CLWV	Color lens, single LED color, dual flashing (left/right), wire lead
RECT-37CLWV	Color lens, single LED color, dual flashing (top/bottom), wire lead

RECT-37L SERIES LIGHTHEADS



RECT-37L Lamp Configurations and Available Colors

WP Connector	Wire Leads	Color
CL	CLW	 A  B  G  R
CLL	CLLW	 AA  BB  GG  RR
CLLV	CLLVW	 AA  BB  GG  RR
L	LW	 A  B  G  R  W
LL	LLW	 AA  AB  AR  AW  BB  BW  GG  RB  RR  RW  WW
LLV	LLVW	 AA  AB  AR  AW  BB  BW  GG  RB  RR  RW  WW

Ordering Example

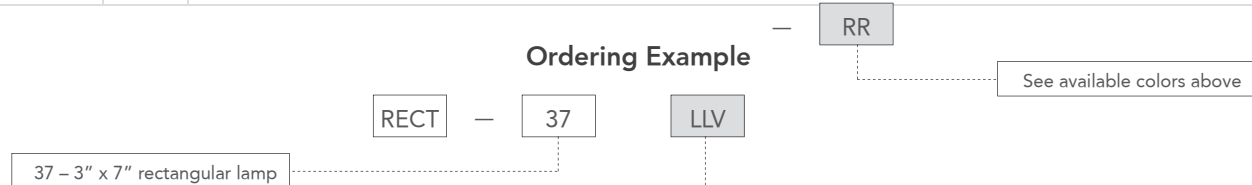

L	Clear lens, single LED color, single flashing	CL	Color lens, single LED color, single flashing
LL	Clear lens, single or dual LED color, dual flashing (left/right)	CLL	Color lens, single LED color, dual flashing (left/right)
LLV	Clear lens, single or dual LED color, dual flashing (top/bottom)	CLLV	Color lens, single LED color, dual flashing (top/bottom)
LW	Clear lens, single LED color, single flashing	CLW	Color lens, single LED color, single flashing
LLW	Clear lens, single or dual LED color, dual flashing (left/right)	CLLW	Color lens, single LED color, dual flashing (left/right)
LLVW	Clear lens, single or dual LED color, dual flashing (top/bottom)	CLLVW	Color lens, single LED color, dual flashing (top/bottom)

Specifications

Item	Description
Voltage	10 thru 30VDC
Current Draw	0.9A @ 12VDC 0.45A @ 28VDC
Warranty	Extended 5 year warranty

LED SERIES LIGHTHEADS



RECT-46L Series

4" x 6" LED Rectangular Lamps

- ultra-high intensity LED's
- wide angle optical lens
- fits all popular emergency vehicles
- five year warranty
- available in many color configurations

The RECT-46L LED lamp family features ultra-high intensity LED's and has a new optical wide angle lens designed to meet the latest KKK ambulance specifications. The lamps are designed for 12-28 VDC operation and have potted electronics for the ultimate in reliability. Expected life is 100,000 hours. Warranty is five years from date of purchase. The lamps come complete with mounting hardware and integrated 12" leads. The RECT-46L series is designed to fit all TOMAR 4" x 6" mounting bezel. The RECT-46L uses TOMAR's wide angle optics, which give a full intensity beam at ± 45 horizontal degrees off axis, making the TOMAR LED the widest angle light in the marketplace! Meets SAE J845 and SAE J1889.

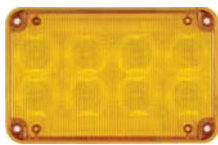

Amber

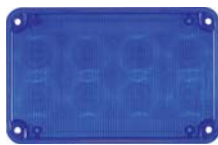

Blue



Clear

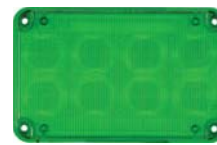

Green



Red

Ordering Information

Please specify lens colors and model number when ordering. Available colors are Amber, Blue, Clear, Green and Red.

Model No.	Description
RECT-46LW	Clear lens, single LED color, single flashing
RECT-46LLW	Clear lens, single or dual LED color, dual flashing (left/right)
RECT-46LLWW	Clear lens, single or dual LED color, dual flashing (top/bottom)
RECT-46CLW	Color lens, single LED color, single flashing
RECT-46CLLW	Color lens, single LED color, dual flashing (left/right)
RECT-46CLLWW	Color lens, single LED color, dual flashing (top/bottom)

RECT-46L SERIES LIGHTHEADS

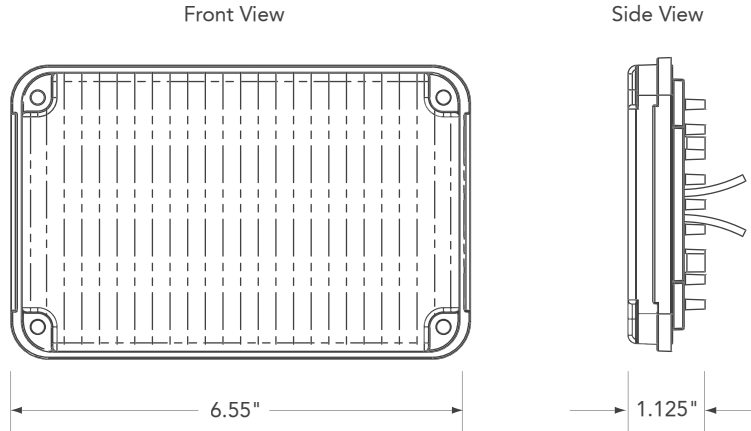

RECT-46L Lamp Configurations and Available Colors

Wire Leads	Color
CLW	A B G R
CLLW	AA BB GG RR
CLLVW	AA BB GG RR
LW	A B G R W
LLW	AA AB AG AR AW BB BG BW GG GR GW RB RR RW WW
LLVW	AA AB AG AR AW BB BG BW GG GR GW RB RR RW WW

Ordering Example



LW	Clear lens, single LED color, single flashing	CLW	Color lens, single LED color, single flashing
LLW	Clear lens, single or dual LED color, dual flashing (left/right)	CLLW	Color lens, single LED color, dual flashing (left/right)
LLVW	Clear lens, single or dual LED color, dual flashing (top/bottom)	CLLVW	Color lens, single LED color, dual flashing (top/bottom)

Specifications

Item	Description
Voltage	10 thru 30VDC
Current Draw	0.9A @ 12VDC 0.45A @ 28VDC
Warranty	Extended 5 year warranty

LED SERIES LIGHTHEADS



RECT-79L Series

7" x 9" LED Rectangular Lamps

- ultra-high intensity LED's
- wide angle optical lens
- fits all popular emergency vehicles
- five year warranty
- available in many color configurations

The RECT-79L LED lamp family features ultra-high intensity LED's and has a new optical wide angle lens designed to meet the latest KKK ambulance specifications. The lamps are designed for 12-28 VDC operation and have potted electronics for the ultimate in reliability. Expected life is 100,000 hours. Warranty is five years from date of purchase. The lamps come complete with mounting hardware, WP connector with 12" leads or integrated 12" leads. The RECT-79L series is designed to fit any TOMAR 7" x 9" mounting bezel. The RECT-79L uses TOMAR's wide angle optics, which give a full intensity beam at ± 45 horizontal degrees off axis, making the TOMAR LED the widest angle light in the marketplace! Meets SAE J845 and SAE J1889.

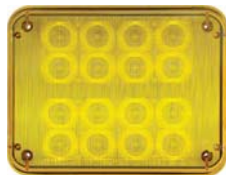

Amber



Blue



Clear



Green



Red

Ordering Information

Please specify lens colors and model number when ordering. Available colors are Amber, Blue, Clear, Green and Red.

Model No.	Description
RECT-79L	Clear lens, single LED color, single flashing
RECT-79LL	Clear lens, single or dual LED color, dual flashing (left/right)
RECT-79LLV	Clear lens, single or dual LED color, dual flashing (top/bottom)
RECT-79CL	Color lens, single LED color, single flashing
RECT-79CLL	Color lens, single LED color, dual flashing (left/right)
RECT-79CLLV	Color lens, single LED color, dual flashing (top/bottom)
RECT-79LW	Clear lens, single LED color, single flashing, wire lead
RECT-79LLW	Clear lens, single or dual LED color, dual flashing (left/right), wire lead
RECT-79LLVW	Clear lens, single or dual LED color, dual flashing (top/bottom), wire lead
RECT-79CLW	Color lens, single LED color, single flashing, wire lead
RECT-79CLW	Color lens, single LED color, single flashing, wire lead
RECT-79CLLW	Color lens, single LED color, dual flashing (left/right), wire lead
RECT-79CLLVW	Color lens, single LED color, dual flashing (top/bottom), wire lead

RECT-79L SERIES LIGHTHEADS

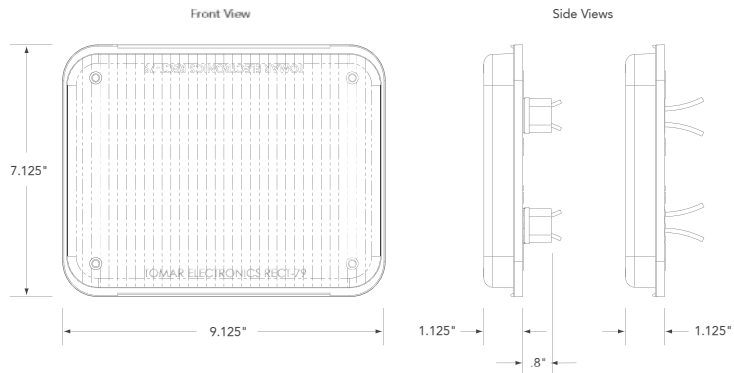

RECT-79L Lamp Configurations and Available Colors

WP Connector	Wire Leads	Color											
CL	CLV												
		A				B			G			R	
CLL	CLLW												
		AA				BB			GG			RR	
CLLV	CLLVW												
		AA				BB			GG			RR	
L	LW												
		A				B			G			R	W
LL	LLW												
		AA	AB	AR	AW	BB	BW	GG	RB	RR	RW	WW	
LLV	LLVW												
		AA	AB	AR	AW	BB	BW	GG	RB	RR	RW	WW	

Ordering Example

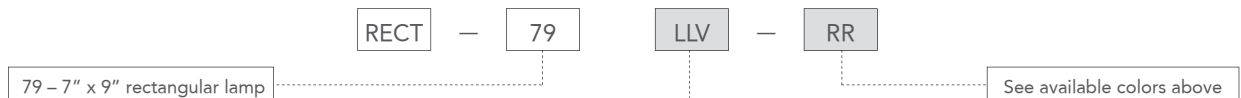

L	Clear lens, single LED color, single flashing	CL	Color lens, single LED color, single flashing
LL	Clear lens, single or dual LED color, dual flashing (left/right)	CLL	Color lens, single LED color, dual flashing (left/right)
LLV	Clear lens, single or dual LED color, dual flashing (top/bottom)	CLLV	Color lens, single LED color, dual flashing (top/bottom)
LW	Clear lens, single LED color, single flashing	CLW	Color lens, single LED color, single flashing
LLW	Clear lens, single or dual LED color, dual flashing (left/right)	CLLW	Color lens, single LED color, dual flashing (left/right)
LLVW	Clear lens, single or dual LED color, dual flashing (top/bottom)	CLLVW	Color lens, single LED color, dual flashing (top/bottom)

Specifications

Item	Description
Voltage	10 thru 30VDC
Current Draw	1.8A @ 12VDC 0.9A @ 28VDC
Warranty	Extended 5 year warranty

LED SERIES LIGHTHEADS



PAR-36L Series 4" Round LED Lamp

- ultra-high intensity LED's
- wide angle optical lens
- fits all popular emergency vehicles
- five year warranty
- available in many color configurations

The PAR-36L LED lamp features ultra-high intensity LED's and has a new optical wide angle lens. The lamps are designed for 12-28VDC operation and have potted electronics for the ultimate in reliability. Expected life is 100,000 hours. Warranty is five years from date of purchase. The lamps come integrated 12" leads. Meets SAE J845 and SAE J1889.



Amber



Blue



Clear



Green



Red

Ordering Information

Please specify lens colors and model number when ordering. Available colors are Amber, Blue, Clear, Green and Red.

Model No.	Description
PAR-36LW	Clear lens, single LED color, single flashing
PAR-36CLW	Color lens, single LED color, single flashing, wire lead

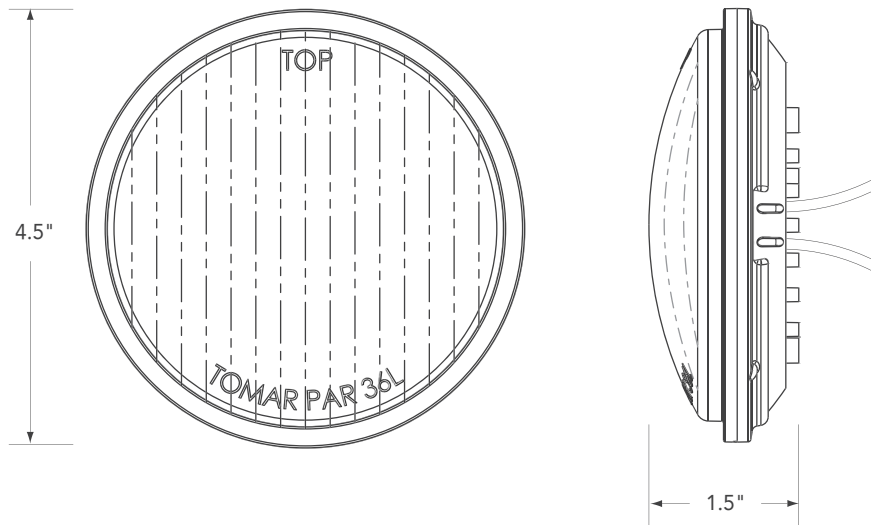

PAR-36L Lamp Configurations and Available Colors

Wire Leads	Color				
CLW					
LW					

Ordering Example



Specifications

Item	Description
Voltage	10 – 30VDC
Current Draw	0.45A @ 12VDC 0.225A @ 28VDC
Warranty	Extended 5 year warranty

SELF-CONTAINED SYSTEMS



200S-BRW-2



200S-BRWV-2 vertical mount



RECT25-W



RECT25-WV vertical mount



RECT25-UM universal mount

200S & RECT25 Windshield Mounted Units

Designed with the latest LED technology, the TOMAR 200S and the iLED™ RECT-25 self-contained windshield mount units provide a sleek low-profile with extreme light output. Lighting units feature a flash selector switch and cigar plug and are available separately or with windshield mount hardware. There are two mounting designs to choose from which ensures a proper fit in any front or rear windshield application.

Available in High Power, Standard Power and Low Current configurations and with multiple flash rates and patterns.

- ultra-high intensity LED's
- three mounting designs
- flash selector switch
- cigar plug
- two year warranty



Flash selector switch



Cigar plug with On/Off switch

Specifications

Item	Description
Windshield Mount	200S Series - 14.24" wide x 2.375" High x 6" Deep (408mm x 63mm x 154mm) RECT25 - 9.75" Wide x 2.375" High x 2.812" Deep (248mm x 63mm x 154mm)
Vertical Mount	200S Series - 13.75" wide x 2.5" High x 2.812" Deep (396mm x 68mm x 73mm) RECT25 - 9.25" Wide x 2.5" High x 2.812" Deep (235mm x 68mm x 73mm)
Universal Mount	RECT25 only - 6.125" Wide x 2.375" High x 6" Deep (235mm x 63 x 154mm)
Current Draw	12 LED unit: 1.6A avg. 9 LED unit: 1.2A avg. 6 LED unit: 0.8A avg.
Operating Temperature	-55°C - +65°C

200S-BRW-2 & RECT25-W WINDSHIELD MOUNTED UNITS

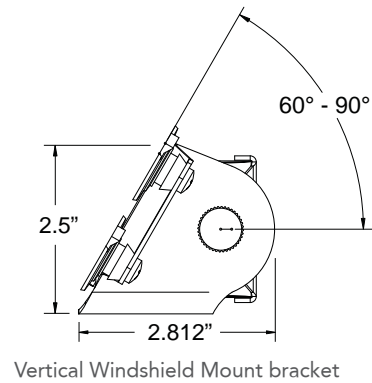
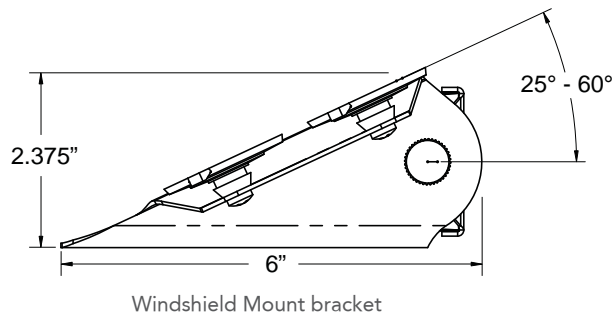

200S-BRW-2

Ordering Information

Available clear lens LED colors are amber, blue, red, green and white. Please specify high power, standard power, low current modules and LED color/s when ordering. Standard features - flash pattern selector switch and cigar plug with on/off switch.

Model No.	Description
200S-BRSW-2	Lightstick with switch
200S-BRW-2	Lightstick with switch and windshield SCP
200S-BRWV-2	Lightstick with switch and vertical windshield SCP
200S-UM-2	Lightstick with switch and universal mount
200S-UMV-2	Lightstick with switch and vertical universal mount

Select optional cable feature

/SWITCH-6FT	6 foot power cable (no cigar plug)
/SWITCH-12FT	12 foot power cable (no cigar plug)

Hardware only

Model No.	Description
200S-2-SC4	Windshield mount bracket for 200S-2 (rail mount only)
200S-2-SC4V	Vertical windshield mount bracket for 200S-2 (rail mount only)

RECT25-W

Ordering Information

Please specify lens colors and model number when ordering. Available in clear lens with colored LEDs in are amber, blue, red, green and white. Colored lenses available in amber, blue and red. Standard features - flash pattern selector switch and cigar plug with on/off switch.

Model No.	Description	Clear Lens - LED-A,B,G,R,W
RECT25-SW-HP	12-LED with switch	
RECT25-W-HP	12-LED with switch and windshield SCP	
RECT25-WV-HP	12-LED with switch and vertical windshield SCP	
RECT25-UM-HP	12-LED with switch, universal mount SCP & 12' cable	
RECT25-UMV-HP	12-LED with switch, vertical universal mount SCP & 12' cable	
RECT25-SW-SD	9-LED with switch	
RECT25-W-SD	9-LED with switch and windshield SCP	
RECT25-WV-SD	9-LED with switch and vertical windshield SCP	
RECT25-UM-SD	9-LED with switch, universal mount SCP & 12' cable	
RECT25-UM-SD	9-LED with switch, vertical universal mount SCP & 12' cable	

Model No.	Description	Clear Lens - LED-A,B,G,R,W
RECT25-SW-LC	6-LED with switch	
RECT25-W-LC	6-LED with switch and windshield SCP	
RECT25-WV-LC	6-LED with switch and vertical windshield SCP	
RECT25-UM-LC	6-LED with switch, universal mount SCP & 12' cable	
RECT25-UMV-LC	6-LED with switch, vertical universal mount SCP & 12' cable	

Model No.	Description	Colored Lens - LED-A,B,R
RECT25-SWC-HP	12-LED with switch	
RECT25-WC-HP	12-LED with switch and windshield SCP	
RECT25-WVC-HP	12-LED with switch and vertical windshield SCP	
RECT25-UMC-HP	12-LED with switch, universal mount SCP & 12' cable	
RECT25-UMVC-HP	12-LED with switch, vertical universal mount SCP & 12' cable	
RECT25-SWC-SD	9-LED with switch	
RECT25-WC-SD	9-LED with switch and windshield SCP	
RECT25-WVC-SD	9-LED with switch and vertical windshield SCP	
RECT25-UMC-SD	9-LED with switch, universal mount SCP & 12' cable	
RECT25-UMVC-SD	9-LED with switch, vertical universal mount SCP & 12' cable	
RECT25-SWC-LC	6-LED with switch	
RECT25-WC-LC	6-LED with switch and windshield SCP	
RECT25-WVC-LC	6-LED with switch and vertical windshield SCP	
RECT25-UMC-LC	6-LED with switch, universal mount SCP & 12' cable	
RECT25-UMVC-LC	6-LED with switch, vertical universal mount SCP & 12' cable	

Select optional cable feature

/SWITCH-6FT	6 foot power cable (no cigar plug)
/SWITCH-12FT	12 foot power cable (no cigar plug)

Hardware only

Model No.	Description
RECT25L-SC4	Windshield mount bracket for RECT25L (rail mount only)
RECT25L-SC4V	Vertical windshield mount bracket for RECT25L (rail mount only)
RECT25L-UM	Universal mount bracket for RECT25L (rail mount only)

SELF-CONTAINED SYSTEMS



TLED-W™
Deck Mount

- ultra-high intensity LED's
- wide angle optical lens
- dash, bumper or visor mounting
- two year warranty
- available in many color configurations

T-LED™

High Intensity LED with Programmable Flash

The T-LED™ LED is a fully self-contained unit featuring a TOMAR RECT-37L 3" x 7" LED rectangular lamp. The T-LED Police Light is available in 30 different lamp colors and configurations. The built-in dual channel LED flasher has 32 user selectable flash patterns stored in memory, and remembers which pattern was used last, displaying that pattern on the next power-up. The T-LED uses TOMAR's wide angle optics, which give a high intensity beam at ± 45 horizontal degrees off axis, making the TOMAR LED the widest angle light in the marketplace! Meets SAE J845 and SAE J1889.



TLED-D™
Dash Mount



TLED-V™
Visor Mount

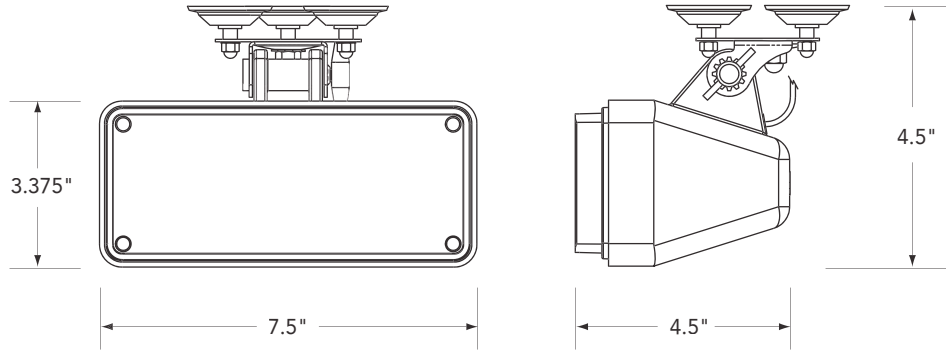

Ordering Information

Please specify lens colors and model number when ordering. Available colors are Amber, Blue, Clear, Green, Red or any split-color combination.

Model No.	Description
TLED-D-LL	Dash warning light, clear lens, left/right flash
TLED-D-LLV	Dash warning light, clear lens, top/bottom flash
TLED-D-CLL	Dash warning light, colored lens, left/right flash
TLED-D-CLLV	Dash warning light, colored lens, top/bottom flash
TLED-V-LL	Visor warning light, clear lens, left/right flash
TLED-V-LLV	Visor warning light, clear lens, top/bottom flash
TLED-V-CLL	Visor warning light, colored lens, left/right flash
TLED-V-CLLV	Visor warning light, colored lens, top/bottom flash
TLED-W-LL	Deck warning light, clear lens, left/right flash
TLED-W-LLV	Deck warning light, clear lens, top/bottom flash
TLED-W-CLL	Deck warning light, colored lens, left/right flash
TLED-W-CLLV	Deck warning light, colored lens, top/bottom flash

Specifications

Item	Description
Voltage	12 thru 28VDC
Current Draw	0.9A – 0.45A (steady burn) 0.4A – 0.2A (flashing)
Size	7.5" wide x 3.375" high x 4.5" deep (190.5mm x 85.7mm x 114.3mm)
Weight	1.4 lbs. (0.625kg)
Light Output	Meets SAE J845 specifications

Replacement Parts

Model No.	Description
PL37-SC	Suction cup
PL37-SC3	Tri-suction cup
PL37-SHIELD	Shields operator from flashing lamp



4620N

20 Watt NEOBE® Lighthouse

- 100% watertight
- extremely durable chrome reflector
- fits all popular emergency vehicles
- two year warranty
- available in five lens colors

The 4620 NEOBE® lighthouse features a RECT-46SWBWP lamp and 20 watt NEOBE® power supply built into its base and potted with polyurethane for weatherproof durability. Film energy storage capacitors provide long life and extreme low and high temperature operation. The 4620N is a cost effective way to incorporate NEOBE® lighting on vehicles without installing lamp cables. The 4620N housing is available in chrome coated ABS.



Amber



Blue



Clear



Green



Red

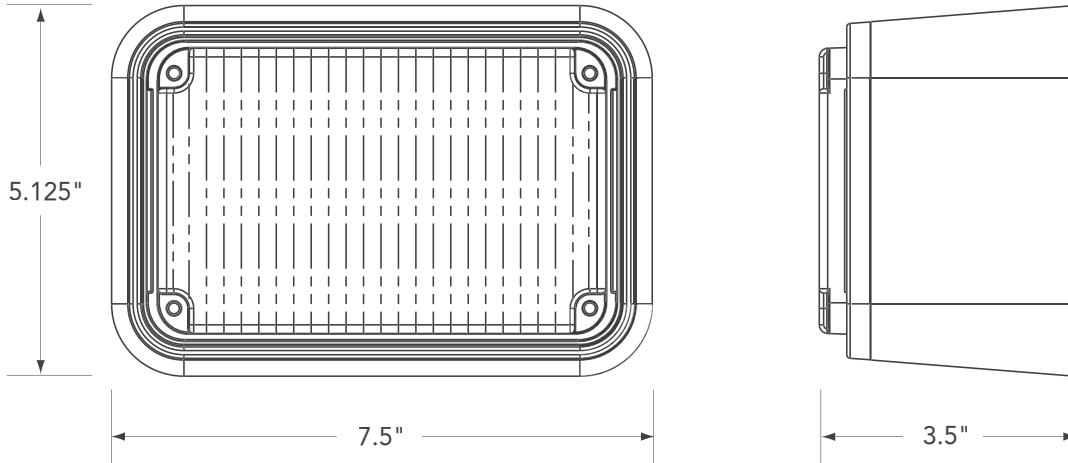

Ordering Information

Please specify lens colors and model number when ordering.

Model No.	Description
4620N-1228-A	20 watt NEOBE® head, amber lens
4620N-1228-B	20 watt NEOBE® head, blue lens
4620N-1228-C	20 watt NEOBE® head, clear lens
4620N-1228-G	20 watt NEOBE® head, green lens
4620N-1228-R	20 watt NEOBE® head, red lens

Specifications

Item	Description
Power Requirements	Draws 2.4 A average @12VDC tapering to 1.1 A average @24VDC
Output Power Rating	20 watts minimum
Flash Rate	60 bursts per minute 6 flashes per burst
Construction	ABS case, polyurethane potting



RECT-34 Series

3" x 4" Rectangular Lamps

- 100% watertight
- extremely durable chrome reflector
- fits all popular emergency vehicles
- available in six lens colors

The RECT-34 series extended lens lightheads are molded from Lexan® and have been designed to fit all popular emergency vehicles. The RECT-34H uses a 27 watt halogen lamp. The RECT-34S uses a strobe flashtube that can be used with any TOMAR strobe power supply. The RECT-34 series features an extended lens design with SIDEOPTICS™ for tri-directional warning light effectivity. The RECT-34 is furnished with a drill template, gasket, and mounting hardware.

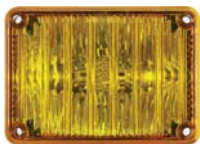

Amber

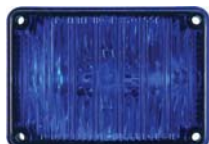

Blue



Clear

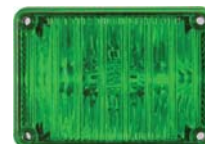

Green



Red

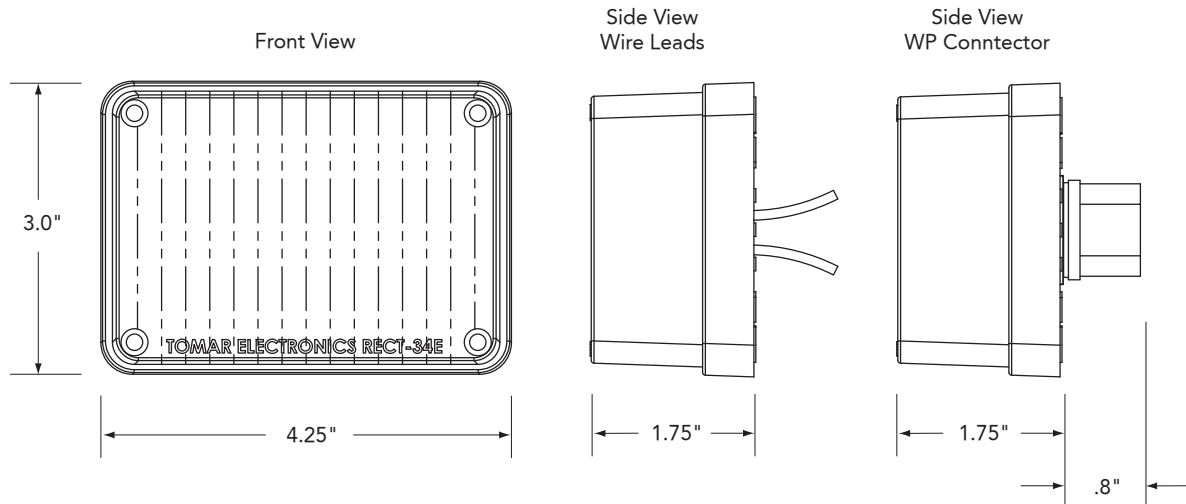

Ordering Information

Please specify lens colors and model number when ordering. Available colors are Amber, Blue, Clear, Green, Purple and Red.

Model No.	Description
RECT-34S	Strobe, 3" x 4" rectangular lamp
RECT-34H	Halogen, 3" x 4" rectangular lamp

Replacement Parts

Model No.	Description
930DM-FLASHER	Flashes one to four 890's, 12VDC, solid state
890	27 watt, 12VDC halogen lamp
890-24	27 watt, 24VDC halogen lamp
890HP	37 watt, 12VDC halogen lamp
890-CONN	Watertight connector for lamp

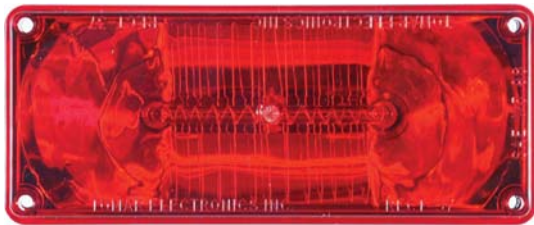

RECT-37 Series

3" x 7" Rectangular Lamps

- 100% watertight
- extremely durable chrome reflector
- fits all popular emergency vehicles
- available in many color configurations

The RECT-37 series sealed beam lamps are 100% watertight and features a chrome coated reflector. It is molded from Lexan® and has been designed to fit all popular emergency vehicles. The RECT-37 is furnished with a drill template, gasket, and mounting hardware; and can be used with all TOMAR power supplies or halogen controllers.



RECT-37S
Single Strobe

The RECT-37S features a single linear strobe lamp. This configuration has the highest intensity of all 3" x 7" lamp models.



RECT-37SS
Dual Strobe

The RECT-37SS uses two strobe lamps and can be used with any TOMAR strobe power supply in simultaneous or alternating flash operation.



RECT-37HS
Halogen/Strobe

The RECT-37HS uses a replaceable #890 automotive 12V halogen lamp rated at 27 watts and a non-replaceable strobe lamp.



RECT-37HWB
Halogen Wide Beam

The RECT-37HWB uses two lamps rated at 27 watts each and can be used as a steady burn or flashing lamp. 54 watt power rating.



RECT-37HNB
Halogen Narrow Beam

The RECT-37HNB uses two lamps rated at 27 watts each and can be used as a steady burn or flashing lamp. 54 watt power rating.

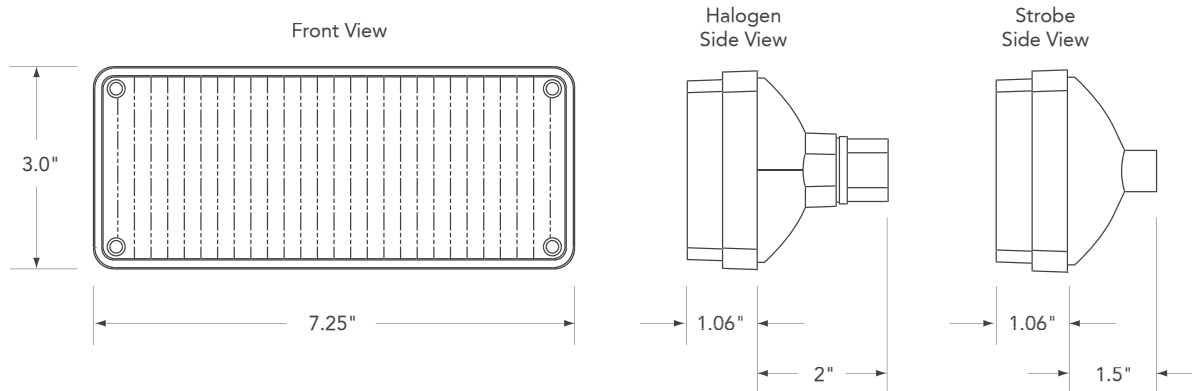

Available Lens Colors:

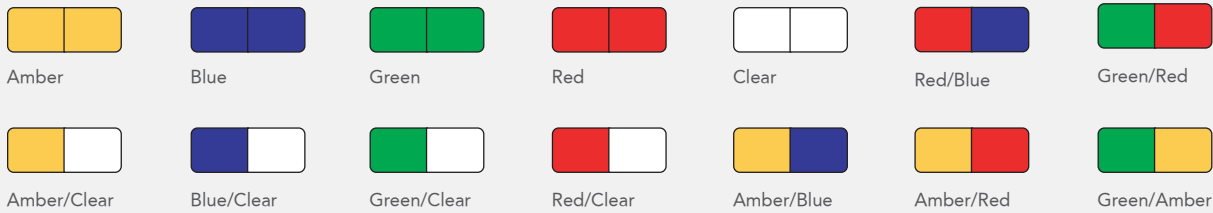

Ordering Information

Please specify lens colors and model number when ordering.

Model No.	Description
RECT-37S	Strobe, 3" x 7" rectangular lamp
RECT-37SS	Dual Strobe, 3" x 7" rectangular lamp
RECT-37HS	Halogen/Strobe combination, 3" x 7" rectangular lamp
RECT-37HWB	Halogen, wide Beam, 3" x 7" rectangular lamp
RECT-37HNB	Halogen, narrow Beam, 3" x 7" rectangular lamp

Replacement Parts

Model No.	Description
930DM-FLASHER	Flashes 1 to 4 890's, 12VDC, solid state
890	27 watt, 12VDC halogen lamp
890-24	27 watt, 24VDC halogen lamp
890HP	37 watt, 12VDC halogen lamp
890-CONN	Watertight connector for lamp
889	27 watt, 12VDC halogen lamp with 90° angled socket base



RECT-46 Series

4" x 6" Rectangular Lamps

- 100% watertight
- extremely durable chrome reflector
- fits all popular emergency vehicles
- available in five lens colors

The model RECT-46 family of remote rectangular lamps is designed to be used with one of TOMAR's high efficiency power supplies or halogen controllers. The RECT-46 lamps have an optional adapter that allow retrofitting into most head lamp warning light sockets on the front of fire vehicles. TOMAR's RECT-46 series features a sealed beam lamp, and the choice of wide beam or narrow beam optics, and are available with both standard or waterproof connectors.



RECT-46SWB
Strobe Wide Beam

The RECT-46S features a sealed beam strobe lamp, potted trigger coil, and wide beam optics. Available in both standard or waterproof connectors.



RECT-46SNB
Strobe Narrow Beam

The RECT-46S features a sealed beam strobe lamp, potted trigger coil, and narrow beam optics. Available in both standard and waterproof connectors.



RECT-46HWB
Halogen Wide Beam

The RECT-46H features a single 12V, 37 watt halogen lamp which is replaceable and waterproof.



RECT-46HNB
Halogen Narrow Beam

The RECT-46H features a single 12V, 37 watt halogen lamp which is replaceable and waterproof.

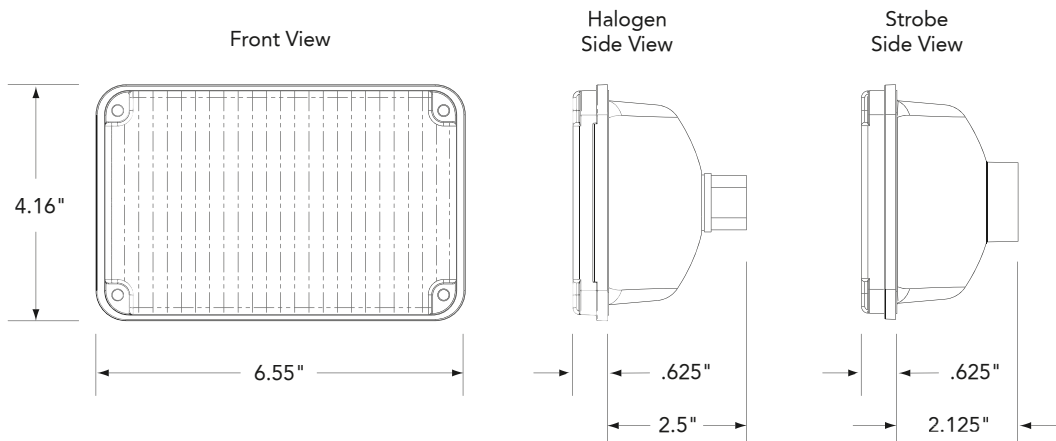

Available Lens Colors:



Amber



Blue



Clear



Green



Red

Ordering Information

Please specify lens colors and model number when ordering.

Model No.	Description
RECT-46SWB	Strobe, Wide Beam, 4" x 6" rectangular lamp
RECT-46SWBWP	Strobe, Wide Beam, 4" x 6" rectangular lamp with waterproof connector
RECT-46SNB	Strobe, Narrow Beam, 4" x 6" rectangular lamp
RECT-46SNBWP	Strobe, Narrow Beam, 4" x 6" rectangular lamp with waterproof connector
RECT-46HWP	Halogen, Wide Beam, 4" x 6" rectangular lamp
RECT-46HNB	Halogen, Narrow Beam, 4" x 6" rectangular lamp

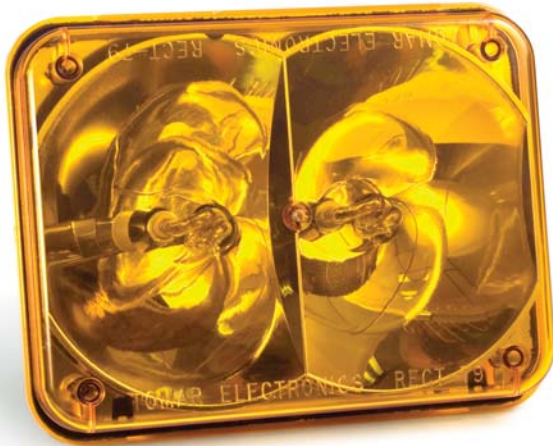

RECT-79 Series 7" x 9" Rectangular Lamps

- 100% watertight
- extremely durable chrome reflector
- fits all popular emergency vehicles
- three year warranty on strobe version
- available in many color configurations

The RECT-79S series lamps are hermetically sealed and is 100% watertight. It is molded from Lexan® and has been designed to fit all popular emergency vehicles and can be used with any TOMAR strobe power supply or halogen controller. Its computer generated stepped optical design creates a hi efficiency reflector making it the brightest strobe light available from any manufacturer, and its hermetically sealed construction will keep it that way for a long time. The RECT-79 series lamps are furnished with a drill template, gasket, and mounting hardware.



RECT-79S
Single Strobe

The RECT-79S features a heavy duty linear flashtube. The stepped optical design creates a high efficiency reflector making it the brightest of all 7" x 9" models.



RECT-79SS
Dual Strobe

The RECT-79SS uses two flashtubes rated at 27 watts each. 54 watt power rating.



RECT-79HS
Halogen/Strobe

The RECT-79HS uses a replaceable #890 automotive 12V halogen lamp rated at 27 watts and a non-replaceable strobe lamp. 54 watts power rating.



RECT-79H
Halogen

The RECT-79H uses two #890 automotive 12V halogen lamps rated at 27 watts each, which can be connected in series for use on 24V automotive systems.

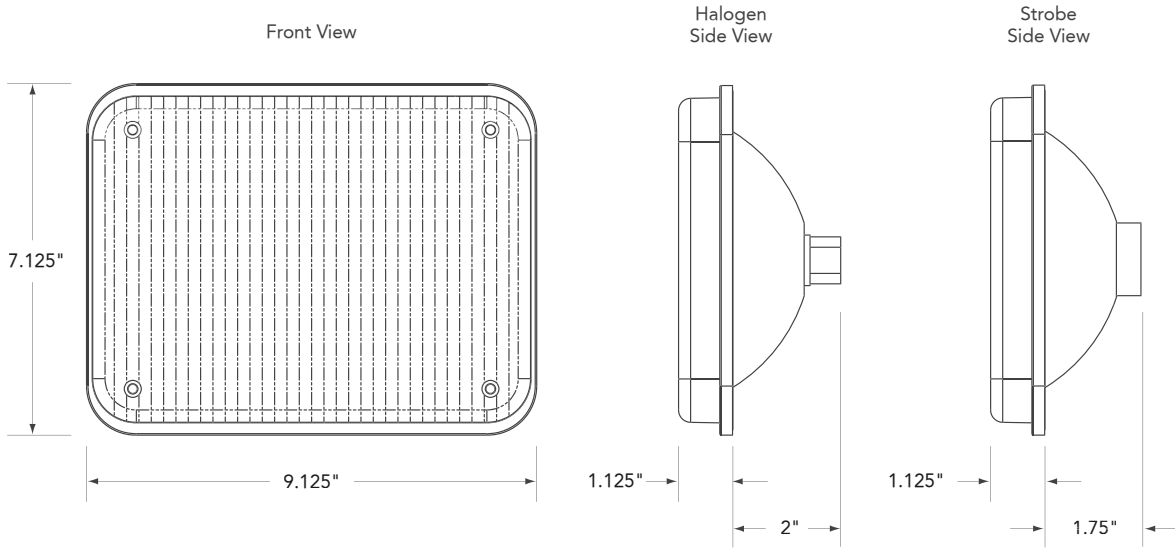

Available Lens Colors:

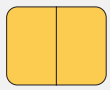

Amber

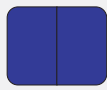

Blue

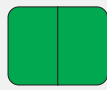

Green

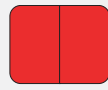

Red

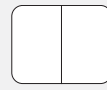

Clear

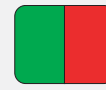

Green/Red

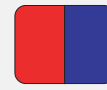

Red/Blue

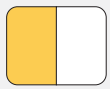

Amber/Clear



Blue/Clear



Green/Clear

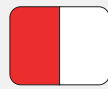

Red/Clear



Amber/Blue



Amber/Red



Green/Amber

Ordering Information

Please specify lens colors and model number when ordering.

Model No.	Description
RECT-79S	Strobe, 7" x 9" rectangular lamp
RECT-79SS	Dual Strobe, 7" x 9" rectangular lamp
RECT-79HS	Halogen/Strobe combination, 7" x 9" rectangular lamp
RECT-79H	Halogen, 7" x 9" rectangular lamp

Replacement Parts

Model No.	Description
930DM-FLASHER	Flashes 1 to 4 890's, 12VDC, solid state
890	27 watt, 12VDC halogen lamp
890-24	27 watt, 24VDC halogen lamp
890HP	37 watt, 12VDC halogen lamp
890-CONN	Watertight connector for lamp
889	27 watt, 12VDC halogen lamp with 90° angled socket base



PAR-36 SERIES

4" Round Lighthouses

The PAR-36, remote strobe heads are designed to be used with TOMAR's strobe or NEOBE® power supplies and feature a sealed beam strobe lamp with a Lexan® lens. The PAR-36, is available with an optional black rubber or stainless steel shells. The halogen versions feature a removable 27 Watt #890 halogen lamp and optional waterproof connectors.



Ordering Information

Please specify lens colors when ordering. PAR-36, PAR-46, PAR-56 colors are Amber, Blue, Clear, Green and Red. PAR-36E colors are Amber, Blue and Red.

Model No.	Description
PAR-36	4" strobe lamp
PAR-36WP	4" strobe lamp, waterproof
PAR-36S	4" sealed strobe lamp, stainless steel shell, 15' cable
PAR-36B	4" sealed strobe lamp, rubber shell, 15' cable
PAR-36H	4" halogen lamp

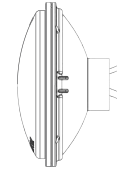
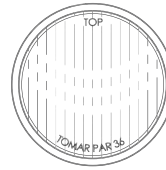

PAR-36

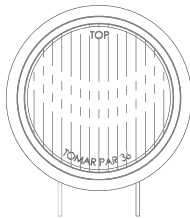

PAR-36B

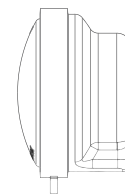
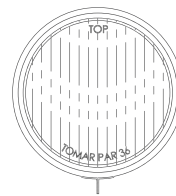

PAR-36S

Specifications

Item	Description
Mounting	Meets the mounting size requirements of SAE J760a
Lens Size	4" diameter (model PAR-36)
890 Halogen Lamp Specifications	Volts: 12.8 Amps: 2.1 ± 10% Life: @ 12.8V : 300 hours Candlepower: 43MSCP

Available Options

Model No.	Description
890-CONN	Watertight connector for halogen lamp (model PAR-36)
890	27 watt, 12VDC halogen lamp (model PAR-36)
930DM-FLASHER	Flashes 1 to 4 890's, 12VDC, solid state (model PAR-36)
PAR-36-SS	PAR-36 stainless steel shell (model PAR-36)
UBKT	Universal stainless steel bracket for PAR-36S lightheads (model PAR-36)
PAR-36B-S	PAR-36 black rubber shell (model PAR-36)
15C	15' cable (model PAR-36)

NOTE: All lightheads are available with waterproof (WP) connectors.

LIGHTHEADS



470-R1
Strobe



700-R1
Strobe



490S-R1
Strobe



801-RL
Strobe



800-RL
Strobe

470, 700, 490S, 495S, 800, 801

Remote Lighthouse

TOMAR's remote strobe lighthouse are designed to be used with all TOMAR's strobe or NEOBE® remote power supplies. TOMAR's remote strobe lighthouse feature 360° Lexan® lenses. The model 801 remote strobe head features a low profile Lexan® MINI LITE lens and a lightweight base that can be flange mounted, 1/2" pipe mounted, or surface mounted. The model 800 remote strobe head features a medium profile Lexan® lens and a lightweight base that can be flange mounted, 1/2" pipe mounted, or surface mounted. All models have replaceable plug-in lamps except for the 470-R1 and 700-R1 which are hermetically sealed assemblies.

Ordering Information

Please specify lens colors and model number when ordering. Available colors are Amber, Blue, Clear, Green, Purple (except 490S-R1) and Red.

Model No.	Description
470-R1	Hermetically sealed, 6" leads, 3.25" high
700-R1	Hermetically sealed, flange mount, 3.25" high
490S-R1	Low profile, 1/2" pipe hub, 6" leads, 5" high
495S-R1	Low profile, 1/2" male thread mount, 5" high
490S-RL-20	Low profile, 1/2" pipe hub, 20' cable, 5" high
495S-RL-20	Low profile, 1/2" male thread, 20' cable, 5" high
801-RL	Pipe mount, 6" leads
801-RL-WP	Pipe mount, 6" leads, waterproof connector
801-RL-15	Pipe mount, 15' cable
800-RL	Pipe mount, 6" leads
800-RL-WP	Pipe mount, 6" leads, waterproof connector
800-RL-15	Pipe mount, 15' cable

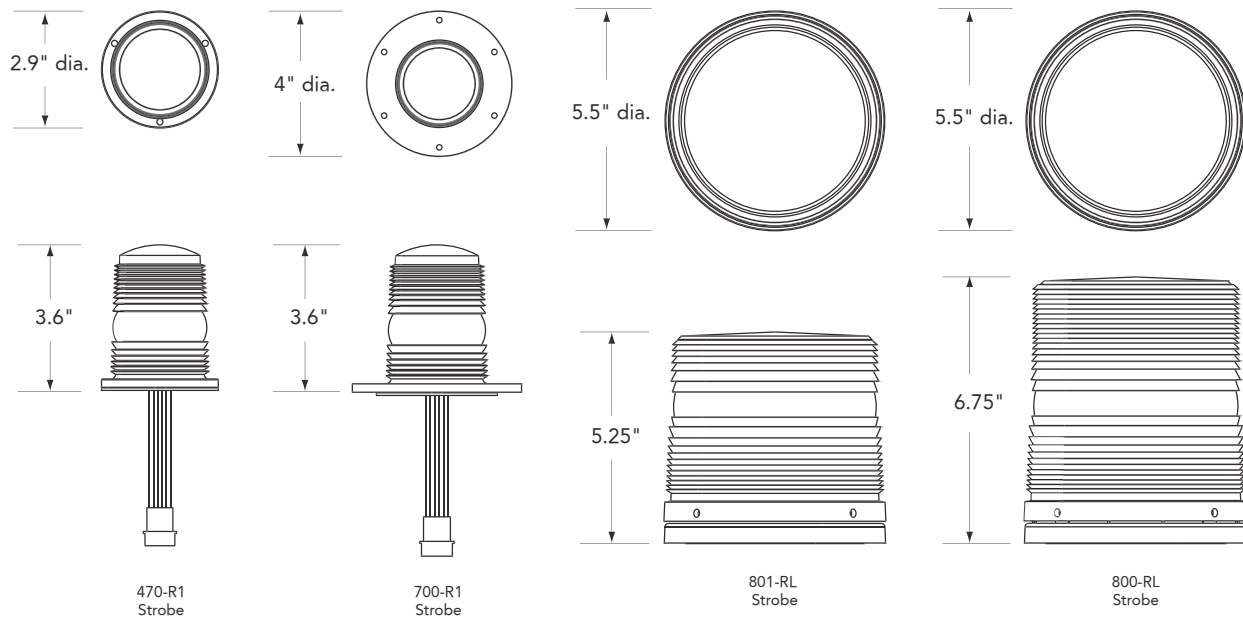

Specifications

Item	Description
Lamp Type	470-RL xenon strobe lamp (models 800, 801) 3001 xenon strobe lamp (model 490-R1)
Size and Weight	3.6" tall x 2.9" dia. (99.4mm x 73.7mm) -- model 470 5.0" tall x 3.0" dia. (127mm x 76.2mm) -- model 490 3.6" tall x 4.0" dia. (99.4mm x 101.6mm) -- model 700 5.25" tall x 5.5" dia. (133mm x 140mm) -- model 801 6.75" tall x 5.5" dia. (171mm x 140mm) -- model 800

Available Options

NOTE: All "/" options are factory installed only.

Model No.	Description
700-DC	Clear lens dust cover (model 700-RL)
/LBO-MINI	180° lens blackout segment (models 470, 490, 495, 700)
802-03	Clear lens dust cover (model 801)
1250-03	Clear lens dust cover (model 800)
/LBO-MINILITE	Lens blackout segment 180° (model 801)
/LBO-MAXI	Lens blackout segment 180° (model 800)
TBO-MAXI	Top lens blackout segment (models 800, 801)
G802	Heavy duty guard (model 801)
G800	Heavy duty guard (model 800)
800-R1-BASE	Base and lamp assembly including lamp (models 800, 801)
800-FLG	Flange mounting ring (models 800, 801)

MOUNTING BEZELS

RECT-34, RECT-37, RECT-46, RECT-79

TOMAR carries various ABS chrome coated or black Lexan® bezels for the RECT-34, RECT-37, RECT-46 and RECT-79 lamps series. The chrome used to coat our bezels is an automotive finish that can withstand exposure to all natural elements and will not peel.

Bezels for RECT-34 Series Lamps

Model No.	Description
RECT-34B	Bumper mount bezel, black Lexan®
RECT-34C	Bumper mount bezel, chrome coated ABS

Bezels for RECT-37 Series Lamps

Model No.	Description
RECT-37B	Bumper mount bezel, black Lexan® with 1 hole mount
RECT-37BF	Bumper mount bezel, black Lexan® with mounting foot
RECT-37C	Bumper mount bezel, chrome coated ABS with 1 hole mount
RECT-37CF	Bumper mount bezel, chrome coated ABS with mounting foot
RECT-37-SMFP	Surface mount bezel, chrome coated ABS
RECT-37-SMFP-B	Surface mount bezel, black Lexan®
RECT-37-DSMFP	Deep surface mount bezel, chrome coated ABS
RECT-37-DSMFP-B	Deep surface mount bezel, black Lexan®

Bezels for RECT-46 Series Lamps

Model No.	Description
RECT-46BZ	Surface mount bezel, chrome coated ABS
RECT-46BZ3	Surface mount tri-bezel, chrome coated ABS
RECT-46LBZ	Surface mount bezel, chrome coated ABS for 4" x 6" LED series
RECT-46-DSMFP	Deep surface mount bezel, chrome coated ABS
RECT-46-ADAPTOR	Adaptor for headlight warning sockets

Bezels for RECT-79 Series Lamps

Model No.	Description
RECT-79BZ	Surface mount bezel, chrome coated ABS
RECT-79-SMFP	Deep surface mount bezel, chrome coated ABS
RECT-79-SMFP-B	Deep surface mount bezel, black Lexan®

RECT SERIES MOUNTING BEZELS

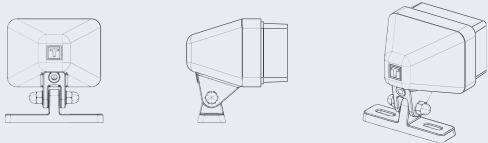

RECT-34B & RECT-34C
Bumper Mount

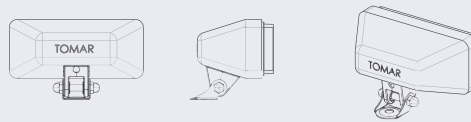

RECT-37B & RECT-37C
Bumper Mount with 1 hole

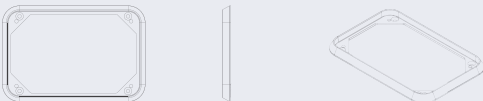

RECT-46BZ
Surface Mount



RECT-37BF & RECT-37CF
Bumper Mount with foot

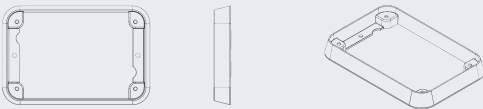

RECT-46LBZ
Surface Mount for LED lamps



RECT-37-SMFP & RECT-37-SMFP-B
Surface Mount

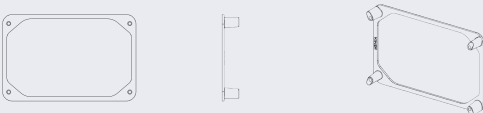

RECT-46-ADAPTOR
Headlight Fixture Mount

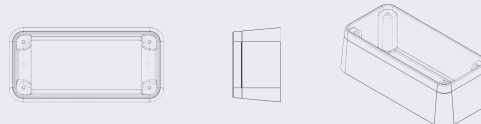

RECT-37-DSMFP & RECT-37-DSMFP-B
Deep Surface Mount

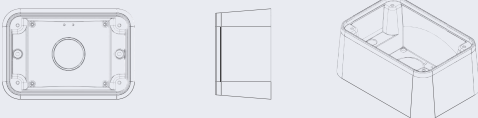

RECT-46-DSMFP
Deep Surface Mount

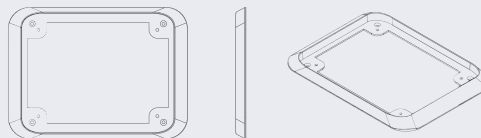

RECT-79BZ
Surface Mount

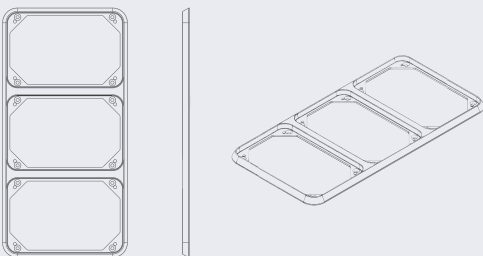

RECT-46BZ3
Surface Mount Tri-bezel

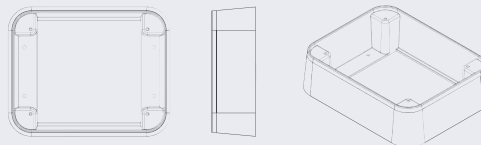

RECT-79-SMFP & RECT-79-SMFP-B
Deep Surface Mount

SCENE LIGHTS

13° and 26° Tilt Down and Flood Lamps

TOMAR's Scene Lights are molded from Lexan® and have been designed to fit all popular emergency vehicles. The RECT-37H, RECT-46H, and the RECT-79H lights can be ordered with a 13° or 26° tilt down angle as well as narrow and wide beam flood lamps. They each use two replaceable GE #890 automotive 12V halogen lamps rated at 27 watts each. These lamps are furnished with drill template, gasket, and mounting hardware. Watertight lamp connectors are included.

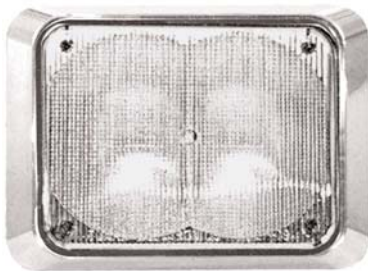

RECT-79H13-C
13° Tilt Down Scene Light
(shown with RECT-79BZ bezel)



RECT-79HNB-C
Halogen Flood Light



RECT-79HNB-CX3
Halogen Flood Light

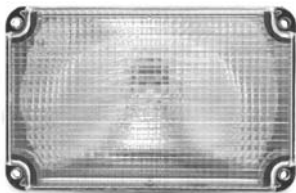

RECT-46H13-C
13° Tilt Down Scene Light



RECT-46HNB-C
Halogen Flood Light

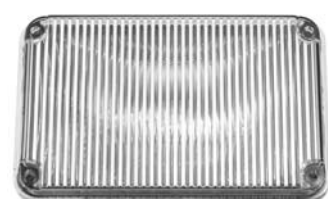

RECT-46HNB-C
Halogen Flood Light

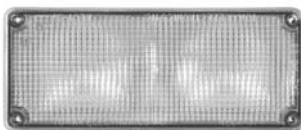

RECT-37H13-C
13° Tilt Down Scene Light



RECT-37HNB-C
Halogen Flood Light

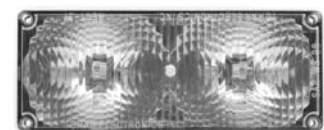

RECT-37HNB-C
Halogen Flood Light

RECT-79 Series

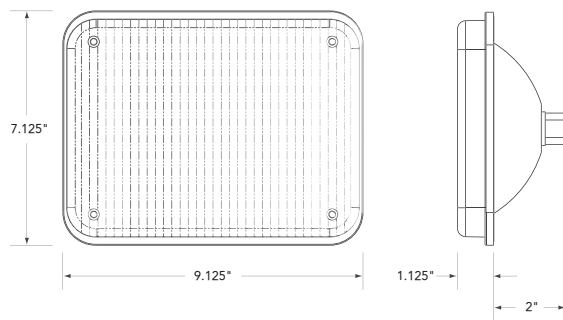

RECT-46 Series

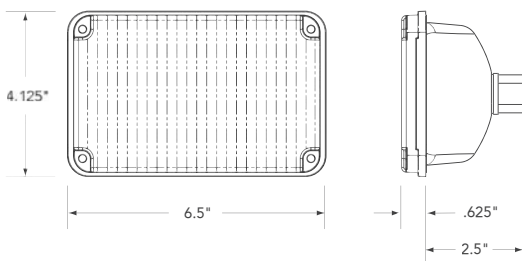

RECT-37 Series

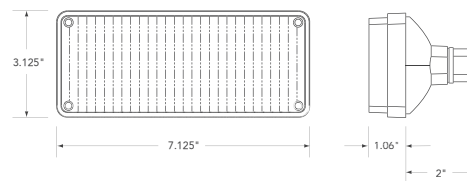

Ordering Information

Model No.	Description
RECT-37H13-C	3" x 7" rectangular halogen lamp, 13° tilt down, clear lens color
RECT-37H26-C	3" x 7" rectangular halogen lamp, 26° tilt down, clear lens color
RECT-37HNB-C	3" x 7" rectangular halogen lamp, clear lens color, narrow beam
RECT-37HNB-C	3" x 7" rectangular halogen lamp, clear lens color, wide beam
RECT-46H13-C	4" x 6" rectangular halogen lamp, 13° tilt down, clear lens color
RECT-46H26-C	4" x 6" rectangular halogen lamp, 26° tilt down, clear lens color
RECT-46HNB-C	4" x 6" rectangular halogen lamp, clear lens color, narrow beam
RECT-46HNB-C	4" x 6" rectangular halogen lamp, clear lens color, wide beam
RECT-79H13-C	7" x 9" rectangular halogen lamp, 13° tilt down, clear lens color
RECT-79H26-C	7" x 9" rectangular halogen lamp, 26° tilt down, clear lens color
RECT-79HNB-C	7" x 9" rectangular halogen lamp, clear lens color, white reflector, wide beam
RECT-79HNB-CX3	7" x 9" rectangular halogen lamp, clear lens color, chrome reflector & trim, wide beam

Replacement Parts

Model No.	Description
RECT-79BZ	Chrome plated Lexan® recessed mount fixture
890	27 watt, 12VDC halogen lamp
890-24	27 watt, 24VDC halogen lamp
890HP	37 watt, 12VDC halogen lamp
889	27 watt, 12VDC halogen lamp with 90° angled socket base
890-CONN	Watertight connector for lamp

POWER SUPPLIES

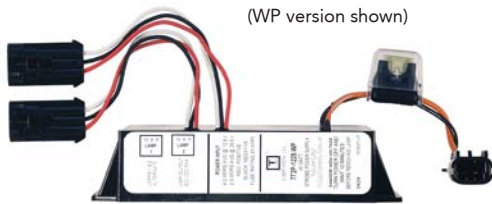

772P-1228 STROBE POWER SUPPLY

The model 772P is an economical remote strobe power supply designed to alternately flash two remote strobe heads at a rate of 70 double flashes per minute each. The unit is small for easy mounting in hard to fit areas. The 772P is fully potted making it vibration and water resistant. The unit features polarity protection, continuous duty circuitry, and RFI filters to protect against radio interference. The 772P operates from 12-28 VDC and is fully protected against shorts or opens in the lamp wiring. The power supply is constructed with a glass filled Lexan® case and polyurethane potting.

Ordering Information

Model No.	Description
772P-1228	2 output strobe power supply, 12-28VDC
772P-1228-WP	(Same as above except with Waterproof connectors)

Power Requirements:

Draws 4.25 A avg. @12VDC tapering to 2.125 A avg. @24VDC

Output Power Rating:

45 Watts minimum

Flash Rate:

70 DFPM/Head minimum

Size:

7.125"(181mm) x 3.75"(95mm) x 1.75" (44mm)

Weight:

2.5lbs (1.12kg.)

Warranty:

Five year warranty

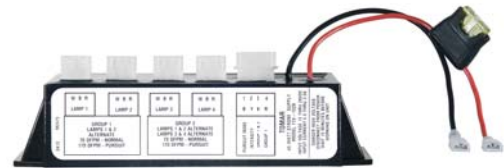

774-1228 STROBE POWER SUPPLY

The model 774 strobe power supply is designed to alternately flash two groups of remote strobe heads in either high or low intensity and normal or pursuit flash rate. The 774 is controlled manually by 4 customer provided SPST low current switches which select high-low intensity, flash rate, lamp group 1 on-off control, and BOTH lamp groups on-off control. All functions may be wired to allow control by a single low current switch if desired. The 774 operates from 12-28VDC and is fully potted making it vibration and water resistant. It also features polarity protection, heavy duty precision circuitry, and RFI filters to minimize radio interference. The power supply is constructed with a glass filled Lexan® case and polyurethane potting.

Ordering Information

Model No.	Description
774-1228	4 output strobe power supply with head cut-out circuitry, intensity control, normal and pursuit flash rates, 12-28VDC
774-1228-WP	(Same as above except with Waterproof connectors)

Power Requirements:

Draws 6.0 A avg. @12VDC tapering to 3.0 A avg. @24VDC

Output Power Rating:

65 Watts minimum in High Intensity
NORMAL Flash Rate, 2 Groups Running

Flash Rate:

NORMAL rate 70 DFPM/Head minimum (140 FPM total)
PURSUIT rate 170 DFPM/Head minimum (340 FPM total)

Control Features:

On-Off and all features are controlled by switching positive, low battery voltage. The main battery power may be left connected to the supply at all times. Current draw is less than 100 microamps in standby.

Size:

7.125"(181mm) x 3.75"(95mm) x 1.75" (44mm)

Weight:

2.5lbs (1.12kg.)

Warranty:

Five year warranty

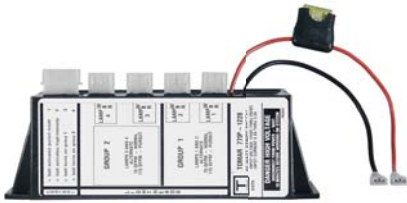

770P-1228 STROBE POWER SUPPLY

The model 770P strobe power supply is designed to alternately flash two groups of remote strobe heads in either high or low intensity and normal or pursuit flash rate. The 770P is controlled manually by 4 customer provided SPST low current switches which select high-low intensity, flash rate, lamp group 1 on-off control, and lamp group 2 on-off control. All functions may be wired to allow control by a single low current switch if desired. The 770P operates from 12–28VDC and is fully potted making it vibration and water resistant. It also features polarity protection, heavy duty precision circuitry, and RFI filters to minimize radio interference. The power supply is constructed with a glass filled Lexan® case and polyurethane potting.

Ordering Information

Model No.	Description
770P-1228	4 output strobe power supply with head cut-out circuitry, intensity control, normal and pursuit flash rates, 12–28VDC
770P-1228-WP	(Same as above except with Waterproof connectors)

Power Requirements:

Draws 6.0 A avg. @12VDC tapering to 3.0 A avg. @24VDC

Output Power Rating:

65 Watts minimum in High Intensity
NORMAL Flash Rate, 2 Groups Running

Flash Rate:

NORMAL rate 70 DFPM/Head minimum (140 FPM total)
PURSUIT rate 170 DFPM/Head minimum (340 FPM total)

Control Features:

On-Off and all features are controlled by switching positive, low battery voltage. The main battery power may be left connected to the supply at all times. Current draw is less than 100 microamps in standby.

Size:

7.125"(181mm) x 3.75"(95mm) x 2.50" (64mm)

Weight:

3.5lbs (1.56kg.)

Warranty:

Five year warranty

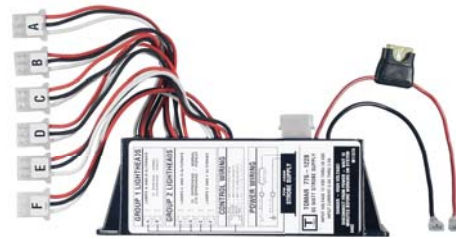

776-1228 STROBE POWER SUPPLY

The model 776 strobe power supply is designed to alternately flash two groups of remote strobe heads in either high or low intensity and normal or pursuit flash rate. The 776 is controlled manually by 4 customer provided SPST low current switches which select high-low intensity, flash rate, lamp group 1 on-off control, and lamp group 2 on-off control. All functions may be wired to allow control by a single low current switch if desired. The 776 operates from 12–28VDC and is fully potted making it vibration and water resistant. It also features polarity protection, heavy duty precision circuitry, and RFI filters to minimize radio interference. The power supply is constructed with a glass filled Lexan® case and polyurethane potting.

Ordering Information

Model No.	Description
776-1228	6 output Strobe power supply with head cut-out circuitry, intensity control, normal and pursuit flash rates, 12–28VDC
776-1228-WP	(Same as above except with Waterproof connectors)

Power Requirements:

Draws 6.0 A avg. @12VDC tapering to 3.0 A avg. @24VDC

Output Power Rating:

65 Watts minimum in High Intensity
NORMAL Flash Rate, 2 Groups Running

Flash Rate:

NORMAL rate 70 DFPM/Head minimum (140 FPM total)
PURSUIT rate 170 DFPM/Head minimum (340 FPM total)

Control Features

On-Off and all features are controlled by switching positive, low battery voltage. The main battery power may be left connected to the supply at all times. Current draw is less than 100 microamps in standby.

Size:

7.125"(181mm) x 3.75"(95mm) x 2.50" (64mm)

Weight:

3.5lbs (1.56kg.)

Warranty:

Five year warranty

POWER SUPPLIES

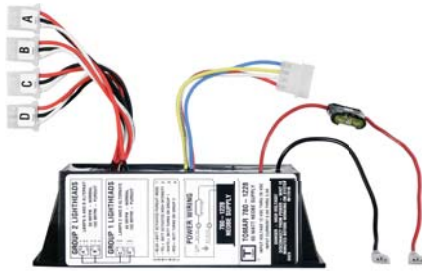

780-1228 NEOBE® POWER SUPPLY

TOMAR model 780-1228 NEOBE® power supply features NEOBE® technology which produces more light per watt than any strobe power supply on the market. TOMAR's model 780-1228 NEOBE® power supply is designed to operate one to four remote strobe heads in a multiple flash alternating pattern. The unit features weatherproof design and hi-low intensity, which may be selected manually by a remote switch or automatically by remote mounted photocell. The 780-1228 operates on 12-28VDC, features head cut-out circuitry to disable sets of heads, polarity protection diode, and contains RFI filters for both high and low band. The TOMAR NEOBE® power supply features a revolutionary strobe circuit that extends the dwell time (on time) of the strobe as well as increasing the life of the strobe lamp by approximately 50%. Any TOMAR remote strobe light head will operate with the model 780-1228 power supply. The power supply is constructed with a glass filled Lexan® case and polyurethane potting.

Ordering Information

Model No.	Description
780-1228	4 output NEOBE® multiple flash power supply, dual intensity. Head control circuitry allows activating of either set of 2 heads or all 4 lamps at the same time, 12-28VDC
780-1228-WP	(Same as above except with Waterproof connectors)

Power Requirements:

6.0 A avg. @12VDC, 3.0 A avg @24VDC

Output Power Rating:

65 Watts minimum in High Intensity
NORMAL Flash Rate, 2 Groups Running

Flash Rate:

60 MFPM/Head-NEOBE rate minimum
100 MFPM/Head-HYPER-NEOBE rate minimum

Flash Pattern:

5 equal power flashes per burst

Control Features

On-Off and all features are controlled by switching positive, low battery voltage. The main battery power may be left connected to the supply at all times. Current draw is less than 100 microamps in standby.

Size:

7.125"(181mm) x 3.75"(95mm) x 2.50" (64mm)

Weight:

3.5lbs (1.56kg.)

Warranty:

Ten year warranty



780-1228-PRE PREEMPTION POWER SUPPLY

The model 780-1228-PRE is TOMAR's newest and most advanced NEOBE®/Preemption power supply. The 780-1228-PRE provides all the warning power and reliability of our NEOBE® technology plus the crystal-locked timing accuracy necessary to generate both industry standard high and low priority preemption signals. The 780-1228-PRE can power 2 or 4 TOMAR lighthoods. Operating features include: 12-28VDC operation, high-low intensity, polarity protection, RFI filters, NEOBE®, HYPER-NEOBE®, and low/high priority preemption flash rates, plus a parking brake override feature to prevent intersection lock-up at the scene of an emergency. The 780-1228-PRE is potted for protection from weather and vibration and it is covered by an extended 10 year warranty, making the 780-1228-PRE the most reliable preemption power supply available. The power supply is constructed with a glass filled Lexan® case and polyurethane potting.

Ordering Information

Model No.	Description
780-1228-PRE	Optical preemption power supply, 12-28VDC
780-1228-PRE-WP	(Same as above except with Waterproof connectors)

Power Requirements:

6.0 A avg. @ 12.8VDC, 3.0 A avg. @ 25.6VDC

Output Power Rating:

65 Watts minimum in High Intensity
NEOBE Flash Rate

Flash Rate:

60 MFPM/Head-NEOBE
100 MFPM/Head-HYPER-NEOBE
Plus High and Low Priority Preemption Frequencies

Flash Pattern:

5 equal power flashes per burst
** NOTE: The Preemption signal is generated by a minimum of 2 alternating lighthoods.

Control Features:

On-Off and all features are controlled by switching positive, low current battery voltage. The main battery power may be left connected to the supply at all times. Current draw is less than 100 microamps in standby.

Size:

7.125"(181mm) x 3.75"(95mm) x 2.50" (64mm)

Weight:

3.5lbs (1.56kg.)

Warranty:

Ten year warranty



782-1228 NEOBE® POWER SUPPLY

TOMAR model 782-1228 NEOBE® power supply features NEOBE® technology which produces the look of neon and the intensity of strobe lighting, combined into one lamp that appears to burn continuously rather than flash. TOMAR's model 782-1228 NEOBE® power supply is designed to operate two remote strobe heads in a multiple flash alternating pattern. The unit features weather proof design and high-low intensity, selected manually by a remote switch or automatically by remote mounted photocell. The 782-1228 operates on 12-28VDC, features polarity protection diode, and contains RFI filters for both high and low band. The TOMAR NEOBE® power supply features a revolutionary strobe circuit that extends the dwell time (on time) of the strobe as well as increasing the life of the strobe lamp by approximately 50%. Any TOMAR remote strobe lighthouse will operate with the model 782-1228 power supply. The power supply is constructed with a glass filled Lexan® case and polyurethane potting.

Ordering Information

Model No.	Description
782-1228	2 output NEOBE® multiple flash power supply, dual intensity, 12-28VDC
782-1228-WP	(Same as above except with Waterproof connectors)

Power Requirements:

2.6 A avg. @14.4VDC, 1.5 A avg. @ 25.6VDC

Output Power Rating:

30 Watts minimum in High Intensity
NEOBE Flash Rate, 2 Lamps Running

Flash Rate:

60 MFPM/Head-NEOBE rate minimum
100 MFPM/Head-HYPER-NEOBE rate minimum

Flash Pattern:

5 equal power flashes per burst

Control Features:

On-Off and all features are controlled by switching positive, low current battery voltage. The main battery power may be left connected to the supply at all times. Current draw is less than 100 microamps in standby.

Size:

7.125"(181mm) x 3.75"(95mm) x 1.75" (44mm)

Weight:

2.5lbs (1.12kg.)

Warranty:

Ten year warranty

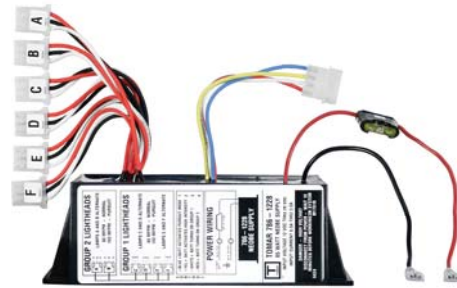

786-1228 NEOBE® POWER SUPPLY

The model 786 NEOBE® power supply is designed to alternately flash two groups of remote strobe heads in either hi or low intensity. The 786 is controlled manually by 3 customer provided SPST low current switches which select high-low intensity, lamp group 1 on-off control, and lamp group 2 on-off control. All functions may be wired to allow control by a single low current switch if desired. The 786-1228 operates on 12-28VDC and is fully potted making it vibration and water resistant. It also features polarity protection, heavy duty precision circuitry, and RFI filters to protect against radio interference. The power supply is constructed with a glass filled Lexan® case and polyurethane potting.

Ordering Information

Model No.	Description
786-1228	6 output NEOBE® power supply with head cut-out circuitry, and intensity control, 12-28VDC
786-1228-WP	(Same as above except with Waterproof connectors)

Power Requirements:

6.0 A avg. @14.4VDC, 3.0 A avg. @ 25.6VDC

Output Power Rating:

65 Watts minimum in High Intensity
NEOBE Flash Rate, 2 Lamps Running

Flash Rate:

60 MFPM/Head-NEOBE rate minimum

Flash Pattern:

5 equal power flashes per burst

Control Features:

On-Off and all features are controlled by switching positive, low current battery voltage. The main battery power may be left connected to the supply at all times. Current draw is less than 100 microamps in standby.

Size:

7.125"(181mm) x 3.75"(95mm) x 2.50" (64mm)

Weight:

3.5lbs (1.56kg.)

Warranty:

Ten year warranty

POWER SUPPLIES



**World's Smallest
NEOBE® Power Supply!**

400-1228 / 401-1228 Mini NEOBE® Power Supply

400-1228 / 401-1228 MINI NEOBE® POWER SUPPLY

The model 400 is a low cost remote NEOBE® power supply designed to alternately flash any two remote strobe heads at a rate of 60 flash bursts per minute each. The unit is a tiny 2" x 3" x 1.5" for easy mounting in any area. The 400 is fully potted making it vibration and water resistant. The unit features polarity protection, continuous duty circuitry, and RFI filters to protect against radio interference. The 400 operates on 12 thru 28VDC and is fully protected against shorts or opens in the lamp wiring.

Ordering Information

Model No.	Description
400-1228	2 output NEOBE® power supply
400-1228-WP	(Same as above except with Waterproof connectors)
401-1228	1 output NEOBE® power supply
401-1228-WP	(Same as above except with Waterproof connectors)
401-CF-1228	1 output continuous flash power supply
401-CF-1228-WP	(Same as above except with Waterproof connectors)

Power Requirements:

Draws 1.85 A avg. @12VDC tapering to 0.9 A avg. @24VDC

Output Power Rating:

20 Watts minimum

Flash Rate:

60 Bursts/MIN/Head
6 Flashes/Burst

Construction:

ABS case, polyurethane potting

Size:

2" (50.8mm) x 3" (76.2mm) x 1.5" (38.1mm)

Weight:

0.6 lbs (276 grams)

Mounting Hole Dimensions:

2 Holes, 0.187" Dia (4.75mm)

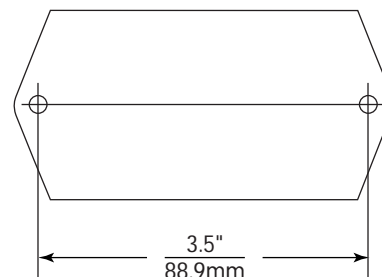

Cable Kits

Cables for Lamps and Power Supplies

TOMAR multi-conductor lamp extension cables are available in eight styles to allow connecting standard lamps and power supplies to WP lamps and power supplies. STD connectors are recommended for use in clean/dry areas only; they are not water tight or weatherproof. WP connectors are recommended for use in damp/wet areas and are sealed with silicone rubber gaskets, and are rated for automotive under hood applications. The cable is shielded 3/C-16AWG 26/30 stranding annealed tinned copper color coded PVC insulated and jacketed and rated for 80°C operation. .274" O.D.



STD. FEMALE
M43A/M37A



STD. MALE
M44A/M38A



WP. MALE
M1054/M1056



WP. FEMALE
M1053/M1055

Ordering Information

Model No.	Cable Length	Cable Type	Connector (Power Supply End)	Connector (Lamp End)
0.5C 2C 6C 9C 15C 20C 25C	6 inches 2 feet 6 feet 9 feet 15 feet 20 feet 25 feet	C	Standard Female	Standard Male
0.5C-WP 2C-WP 6C-WP 9C-WP 15C-WP 20C-WP	6 inches 2 feet 6 feet 9 feet 15 feet 20 feet	C	WP Male	Standard Male
0.5C-WP1 6C-WP1 9C-WP1 15C-WP1 20C-WP1	6 inches 6 feet 9 feet 15 feet 20 feet	C-WP	Standard Female	WP Female
2C-WP2 6C-WP2 9C-WP2 15C-WP2 20C-WP2	2 feet 6 feet 9 feet 15 feet 20 feet	C-WP	WP Male	WP Female

Model No.	Cable Length	Cable Type	Connector (Power Supply End)	Connector (Lamp End)
2-2LH 4-2LH 15-2LH 20-2LH 35-2LH	2 feet 4 feet 15 feet 20 feet 35 feet	2LH	Standard Female	Standard Male
2-2LH-WP 4-2LH-WP 15-2LH-WP 20-2LH-WP 35-2LH-WP	2 feet 4 feet 15 feet 20 feet 35 feet	2LH-WP	WP Male	Standard Male
2-2LH-WP1 4-2LH-WP1 15-2LH-WP1 20-2LH-WP1 35-2LH-WP1	2 feet 4 feet 15 feet 20 feet 35 feet	2LH-WP1	Standard Female	WP Female
2-2LH-WP2 4-2LH-WP2 15-2LH-WP2 20-2LH-WP2 35-2LH-WP2	2 feet 4 feet 15 feet 20 feet 35 feet	2LH-WP2	WP Male	WP Female

*Special lengths can be made to order.

Undercover Systems

770C, 772C, 774C, 780C and 782C



TOMAR's Undercover Strobe Systems provide the ultimate warning light performance for low profile and unmarked emergency vehicles. The compact strobe lamp assembly is custom mounted inside new style headlight and taillight composite housings. The Undercover Systems feature high intensity strobe lamps, water resistant power supplies, and interconnect-cable kits.

- Lamps available in Amber, Blue, Clear and Red.
- 5 year warranty on 770 series power supplies.
- 10 year warranty on 780 series power supplies.

Installed view of vehicle front



Installed view of vehicle rear

Two Head Systems

772C–SYS Strobe System (two head system)

Qty	Description
2	4701 or 470–RL
1	772P–1228
2	15C cables

782C–SYS NEOBE® System (two head system)

Qty	Description
2	4701 or 470–RL
1	782–1228
2	15C cables

772C–SYS–WP Strobe System (two head waterproof system)

Qty	Description
2	4701–WP or 470–RLWP–C
1	772P–1228–WP
2	15C–WP2 cables

782C–SYS–WP NEOBE® System (two head waterproof system)

Qty	Description
2	4701–WP or 470–RLWP–C
1	782–1228–WP
2	15C–WP2 cables

Four Head Systems

770C–SYS Strobe System (four head system)

Qty	Description
4	4701 or 470–RL
1	770P–1228
2	15C cables
2	20C cables

774C–SYS Strobe System (four head system)

Qty	Description
4	4701 or 470–RL
1	774–1228
2	15C cables
2	20C cables

780C–SYS NEOBE® System (four head system)

Qty	Description
4	4701 or 470–RL
1	780–1228
2	15C cables
2	20C cables

770C–SYS–WP Strobe System (four head waterproof system)

Qty	Description
4	4701–WP or 470–RLWP–C
1	770P–1228–WP
2	15C–WP2 cables
2	20C–WP2 cables

774C–SYS–WP Strobe System (four head waterproof system)

Qty	Description
4	4701–WP or 470–RLWP–C
1	774–1228–WP
2	15C–WP2 cables
2	20C–WP2 cables

780C–SYS–WP NEOBE® System (four head waterproof system)

Qty	Description
4	4701–WP or 470–RLWP–C
1	780–1228–WP
2	15C–WP2 cables
2	20C–WP2 cables

Six Head Systems

776C–SYS Strobe System (six head system)

Qty	Description
6	4701 or 470–RL
1	776–1228
4	15C cables
2	20C cables

786C–SYS NEOBE® System (six head system)

Qty	Description
6	4701 or 470–RL
1	786–1228
2	6C cables
2	9C cables
1	15–2LH

776C–SYS–WP Strobe System (six head waterproof system)

Qty	Description
6	4701–WP or 470–RLWP–C
1	776–1228–WP
4	15C–WP2 cables
2	20C–WP2 cables

786C–SYS–WP NEOBE® System (six head waterproof system)

Qty	Description
6	4701–WP or 470–RLWP–C
1	786–1228–WP
2	6C cables
2	9C cables
1	15–2LH

STROBE AND LED SYSTEMS



400 SERIES STROBE SYSTEMS

400-SYSTEMS

- chrome or black Lexan® housings
- multiple lamp options
- easy to install
- 100% waterproof

TOMAR 400 series strobe systems feature our small 400-1228 power supply. The power supply measures 2" x 3" x 1.5", for easy mounting in any area and designed to alternately flash any two remote strobe heads at a rate of 60 flash bursts per minute each. The 400-1228 has polarity protection, continuous duty circuitry, and RFI filters to protect against radio interference, operates on 12 thru 28VDC, and fully protected against shorts or opens in the lamp wiring.

These systems can be ordered with either 3" x 4", 3" x 7" or hideaway lamps. The lamp housings are available in either chrome or black Lexan®.

Ordering Information

Please specify lens colors and model number when ordering. Available colors are Amber, Blue, Clear, Green and Red.

Model No.	Description
400-SYS-34B	two 3" x 4" strobe lamp heads in black Lexan® housing
400-SYS-34C	two 3" x 4" strobe lamp heads in chrome ABS housing
400-SYS-37B	two 3" x 7" strobe lamp heads in black Lexan® housing
400-SYS-37C	two 3" x 7" strobe lamp heads in chrome ABS housing
400-SYS-37B/SS	one dual strobe lamp head in black Lexan® housing
400-SYS-37SMFP	two 3" x 7" strobe lamp head in chrome ABS surface mount bezels
400C-SYS-WP	two 4701-WP undercover lamp heads



400-SYS-34B

Qty.	Description
2	3" x 4" RECT-34SWP strobe lamps in black Lexan® housings
1	400-1228-WP power supply
2	15C-WP2 cables

400-SYS-34C

Qty.	Description
2	3" x 4" RECT-34SWP strobe lamps in chrome Lexan® housings
1	400-1228-WP power supply
2	15C-WP2 cables



400-SYS-37C

Qty.	Description
2	3" x 7" RECT-37SWP strobe lamps in chrome Lexan® housings
1	400-1228-WP power supply
2	15C-WP2 cables

400-SYS-37B

Qty.	Description
2	3" x 7" RECT-37SWP strobe lamps in black Lexan® housings
1	400-1228-WP power supply
2	15C-WP2 cables



400C-SYS-WP

Qty.	Description
2	4701-WP undercover lamp heads
1	400-1228-WP power supply
2	15-2LH-WP2 cables

400-SYS-37SMFP

Qty.	Description
2	3" x 7" RECT-37SWP strobe lamps in chrome surface mount bezels
1	400-1228-WP power supply
2	15C-WP2 cables

400-SYS-37B/SS

Qty.	Description
1	3" x 7" RECT-37SSWP dual strobe lamp in black Lexan® housings
1	400-1228-WP power supply
1	15-2LH-WP2 cables



All 400 systems include one 400-1228-WP power supply, two 15' lamp cables and two strobe lamp heads. Systems are ordered based on the style of lamp head preferred.

STROBE AND LED SYSTEMS



RECT-79L-R



RECT-79L-W

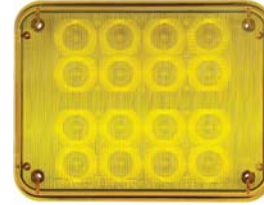

RECT-79L-A



RECT-37L-R



930L-24-KKK



AMBSYS-SW2
Switch Panel

LED-AMBSYS-01 Ambulance LED System

The TOMAR model LED-AMBSYS-01 Ambulance Emergency Warning Light System produces the "KKK" lighting pattern. The LED controller is shipped completely assembled and includes terminal blocks for power and control wiring termination to make installation easy and error free. The LED controller is covered by a 5 year warranty. A two gang switch is included for mode and intensity control.

Ordering Information

Model No.	Description
LED-AMBSYS-01	KKK Ambulance LED System includes: 1 930L-24-KKK LED Flasher 4 RECT-37L-R grill and front fender lamps 8 RECT-79L-R corner lamps 2 RECT-79L-W front center (or 1 RECT-79HWP-C) 1 RECT-79L-A rear center 11 RECT-79Z bezel 4 RECT-37-SMFP bezel 1 AMBSYS-SW2 Switch Panel

Specifications

Item	Description
Voltage and Amperage 12VDC	Primary Mode: 14 lights (when using optional 2 rear lightheads, amperage draw increases by approximately 10%), Day 12.5A average Night 7A average Secondary Mode: 9 lights, Day 8A average Night 4.5A average
Operation	Per Federal Ambulance Specification No. KKK-A-1822E



RECT-79HWB-C
shown in
RECT-79-15-DEG bezel



RECT-79HWB-C

AMBSYS-04 and AMBSYS-05 Ambulance Scene Packages

AMBSYS-04 Scene Package

The AMBSYS-04 Ambulance Scene Package is a set of six RECT-79HWB-C white reflector flood lights installed in RECT-79-15-DEG, 15° mounting bezels which angle the light down. This package is ideal for installation on ambulance boxes or other public service vehicles in need of flood lights.

AMBSYS-05 Scene Package

The AMBSYS-05 Ambulance Scene Package is a set of six RECT-79HWB-CX3 silver reflector flood lights. The RECT-79HWB-CX3 flood lights have a chrome outer edge that surrounds the lamps giving the light a built-in-bezel look; therefore, no need for additional bezel costs.

Ordering Information

Model No.	Description
AMBSYS-04	Scene package includes: 6 RECT-79HWB-C 7" x 9" flood lamps 6 RECT-79-15-DEG mounting bezels (mounted with lamp)
AMBSYS-05	Scene package includes: 6 RECT-79HWB-CX3 7" x 9" flood lamps

Replacement Parts

Model No.	Description
890	890 halogen lamp
890-CONN	Waterproof connector for lamp

Specifications

Item	Description
Lamp Type	890 12.8V Halogen Lamp
Voltage and Amperage	12VDC draws 2.5A per halogen bulb



NFPA Systems

NFPA 1901 Certified Fire Apparatus Systems

TOMAR offers a variety of emergency warning lamp configurations to meet NFPA certified systems requirements. Our NFPA systems can be configured with LED, Strobe and Halogen combinations.

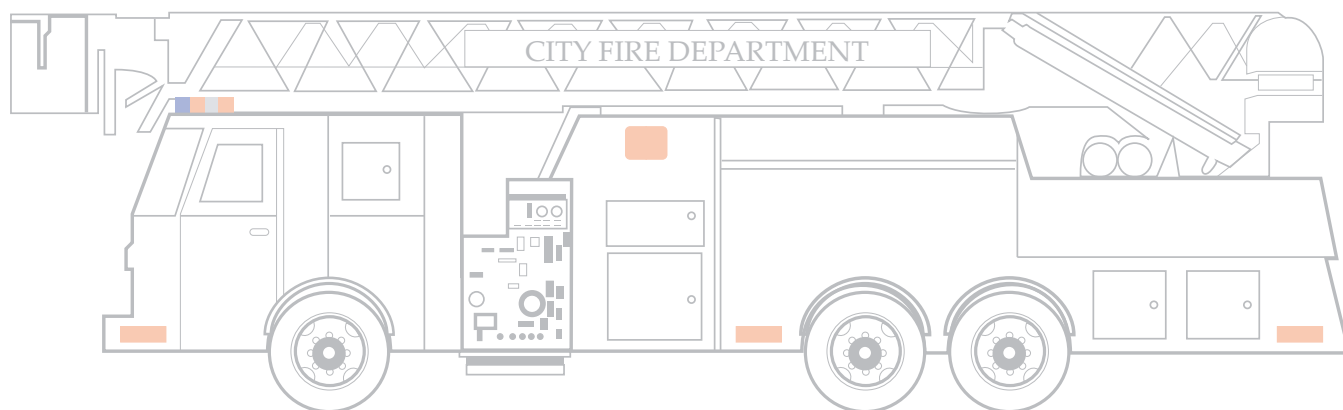

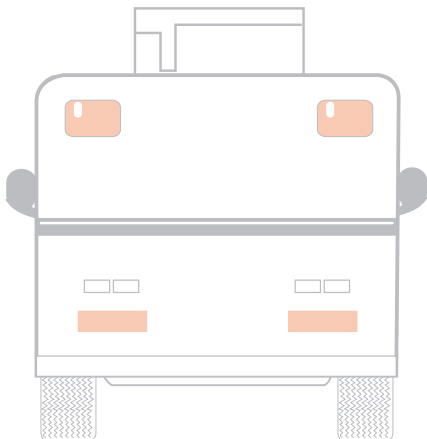
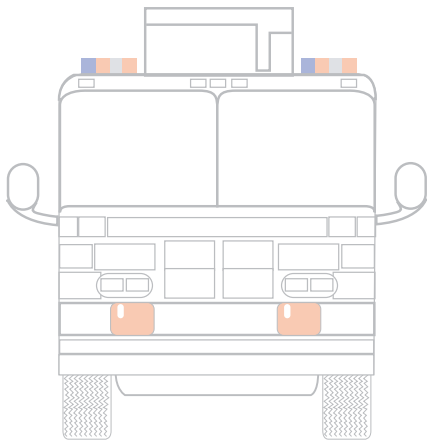
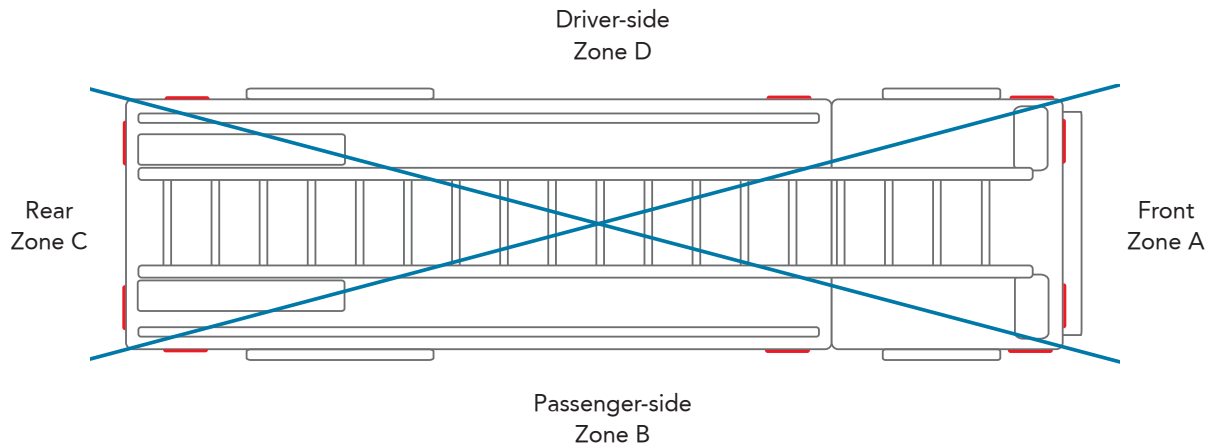

TOMAR's NFPA certified systems are configured to provide the highest visibility and recognition that fire, rescue and command apparatus vehicles demand.

TOMAR offers a wide arrangement of packages to meet a Zonal, Upper level, Lower level, or complete Fire Apparatus applications. These packages can be configured for apparatus specific requirements.

For more information, visit our website at www.tomar.com/products/vehsys/nfpa.htm



MICRO IV™

Low Profile - Single Flash Strobe

- wide input voltage range
- universal mounting
- built-in RFI filters
- potted power supply
- xenon strobe lamp
- ten year warranty on power supply
- one year warranty on lamp
- available in six lens colors
- UL recognized (all models)

The MICRO IV strobe family is an enhanced version of the MICROSTROBE featuring a power supply which operates over a wide input voltage range of 12–80VDC or 16–24VAC. The supply has a regulated output so that the lamp brightness and flash remain constant when operated over the rated input voltage range. The power supply is potted in polyurethane for the ultimate in protection from moisture and vibration. The enclosure is all Lexan®, and the plug-in lamp is field replaceable. All units are polarity protected and have built-in filters to protect against radio interference and spike voltages. The MICRO IV is covered by a 10 year warranty. The MICRO IV and its guard are UL component recognized for type E, EE, and ES electric industrial trucks covered by UL standard #583.

Available Lens Colors



Ordering Information

Please specify lens colors and model number when ordering.

Model No.	Description	Voltage
470SSGP-1280	DC strobe, wall plate mount	12 – 80VDC
470S-1280	DC strobe, surface mount	12 – 80VDC
470SMB-1280	DC strobe, magnetic mount and 6' straight cord	12 – 80VDC
470SMB-1280/CC	DC strobe, magnetic mount and coil cord	12 – 80VDC
490S-1280	DC strobe, 1/2" female pipe mount	12 – 80VDC
492S-1280	DC strobe, 3/4" IPS slip mount	12 – 80VDC
495S-1280	DC strobe, 1/2" male thread mount	12 – 80VDC

MICRO IV STROBE BEACON

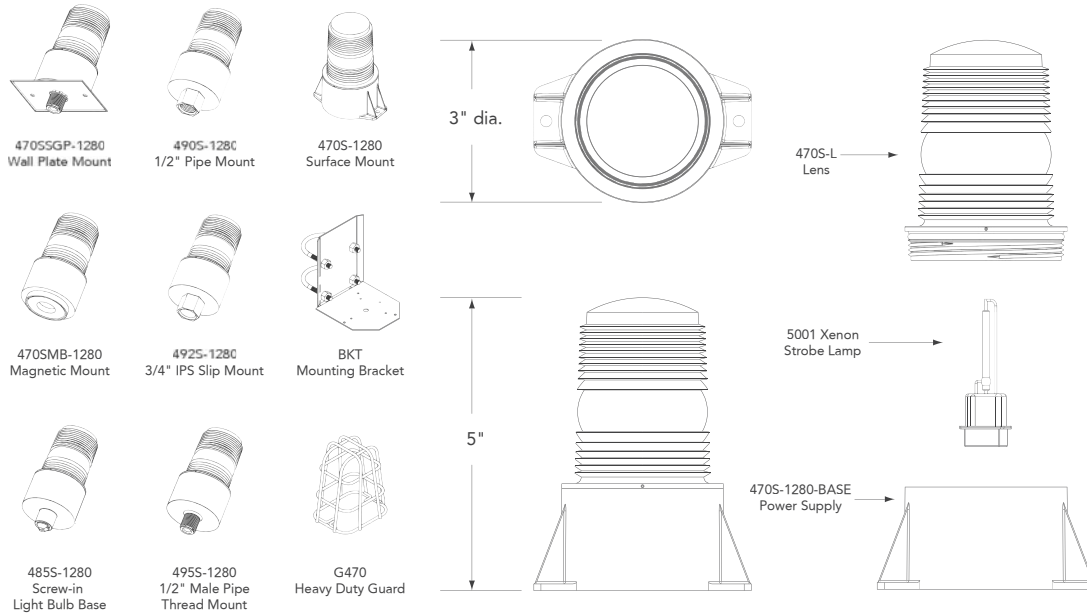

Specifications

Item	Description
Voltage and Amperage	12-80VDC draws 0.4A average @ 12VDC tapering to 0.05A average @ 80VDC 16-24VAC draws 0.35A average
Power Supply Output 2.7 Watts	1.75 joules per flash
Flash Rate	60 to 80 flashes per minute
Size and Weight	5" tall x 3" dia. x 0.6 lbs (127mm x 76mm x 0.27kg)

Available Options

NOTE: All "/" options are factory installed only.

Model No.	Description
G470	Heavy duty guard
BKT	Mounting bracket
LBO-MINI	Lens blackout segment 180°
MICROSHIELD	Vinyl, 180° lens blackout

Replacement Parts

Model No.	Description
5001	Xenon strobe lamp
4705-L	Colored lens (please specify color)
4705-1280-PSA	12 – 80VDC power supply, surface mount
4705MB-1280-PSA	12 – 80VDC power supply, magnetic mount and 6' straight cord
4705MB-1280/CCB	12 – 80VDC power supply, magnetic mount and coil cord
4905-1280-PSA	12 – 80VDC power supply, 1/2" female pipe mount
4925-1280-PSA	12 – 80VDC power supply, 3/4" IPS slip mount
495S-1280-PSA	12 – 80VDC power supply, 1/2" male thread mount



824 MULTI STROBE

Medium Profile - Double or Quad Flash

The model 824 family is a medium profile, multi-flash strobe light which can be changed by the customer from double flash to quad flash operation. It features universal mounting, full size 360° Lexan® lens, high efficiency regulated solid state power supply, and heavy duty xenon strobe lamp. DC units have polarity protection and built-in filters to protect against radio interference and spike voltages. AC units are designed to withstand multiple line transient spikes of 6000V without damage. The model 824 strobe features a fully potted, Lexan®, multi-purpose mounting base which is vibration and water resistant, and has a plug-in strobe lamp and photocell which can be activated to automatically reduce intensity during nighttime operation.

- universal mounting
- built-in RFI filters
- solid state power supply
- xenon strobe lamp
- five year warranty on power supply
- one year warranty on lamp
- available in six lens colors
- UL listed (AC models only)

Available Lens Colors

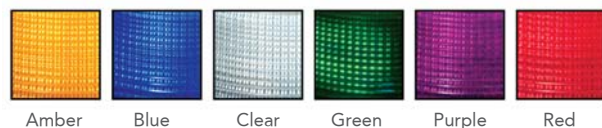

Ordering Information

Please specify lens colors and model number when ordering.

Model No.	Description	Voltage/Frequency
824-110	AC strobe with 10" leads, UL listed	120VAC, 50/60Hz
824LC-110	AC strobe with AC cord set, UL listed	120VAC, 50/60Hz
824-240	AC strobe with 10" leads, UL listed	240VAC, 50/60Hz
824-1228	DC strobe with 10" leads	12 - 28VDC
824MB-1228	DC strobe with magnetic mount and 10' coil cord	12 - 28VDC
824MBSC-1228	DC strobe with magnetic mount and 10' straight cord	12 - 28VDC

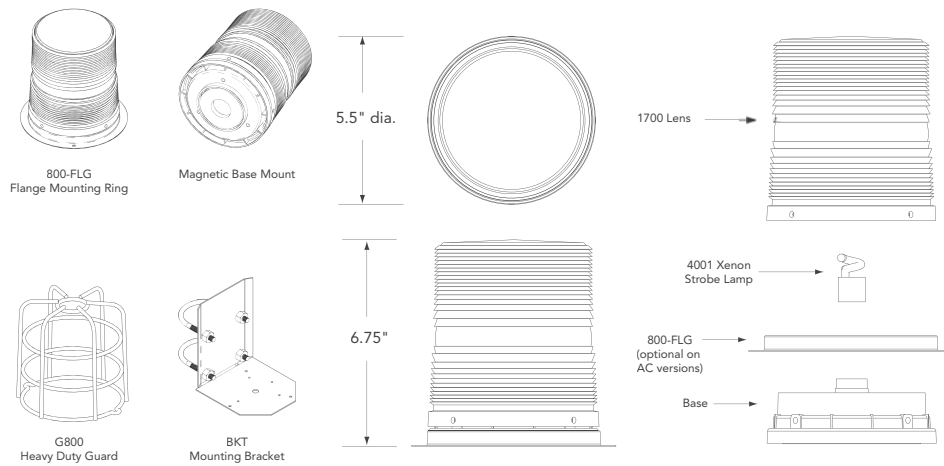

Specifications

Item	Description
Voltage and Amperage	12-28VDC draws 2.2 to 2.4A @ 12V tapering to 1.2 to 1.4A @ 28V at hi intensity 120VAC draws 0.8A peak, 0.5 to 0.6A average 240VAC draws 0.8A peak, 0.5 to 0.6A average
Power Supply Output @ 240V Input	17 joules per double flash 25 joules per quad multi-flash
Flash Rate	68 to 72 double flashes per minute 58 to 62 quad multi-flashes per minute
Size and Weight	6.75" tall x 5.5" dia. x 2.2 lbs (171mm x 140mm x 1.06kg)
Temperature Rating	-40°c to +71°c

Available Options

NOTE: All "/" options are factory installed only.

Model No.	Description
BKT	Mounting bracket
/LBO-MAXI	Lens blackout segment 180°
800/1250-DC	Clear lens dust cover
G800	Heavy duty guard
TBO-MAXI	Top lens blackout
800-FLG	Chrome flange mounting ring (standard on DC versions, optional on AC versions)

Replacement Parts

Model No.	Description
4001	Xenon strobe lamp
1700	Color lens (please specify color)
824-110-BASE	120VAC power supply
824LC-BASE	120VAC power supply with AC cord set
824-240-BASE	208/240VAC power supply
824-1228-BASE	12-28VDC power supply
824MB-BASE	12-28VDC power supply with magnetic mount and coil cord
824MB-SCBASE	12-28VDC power supply with magnetic mount and straight cord

948L-DCP

Siren and Digital Control Panel



948L-DCP

Tomar's 948L-DCP digital control panel features six programmable function switches, a three position progressive mode switch allowing Jump To Mode™ activation as well as a traffic direction switch for use with TOMAR LED or NEOBE® lightbars equipped with the traffic direction option or arrowsticks. The 948 has a comfortable rotary switch to select between siren tones or RRB. The control panel is backlit with LED indicators for easy identification and features a spill resistant housing.

- Arrow function button
- Three position progressive slide switch
- Six independent auxiliary switches
- LED indicator for directional arrow and warning modes
- LED backlighting for night time visibility
- Rotary switch for siren tone selection



Shown with 948-MTGBKT
Universal mounting bracket

Ordering Information

Model No.	Description
948L-DCP	Siren and digital control panel

Specifications

Item	Description
948L-DCP Dimensions	142mm x 66mm x 45mm (5.625" x 2.625" x 1.75")
Operating Temperature Range	-55°C to +65°C
Input Voltage Range	12 VDC

940 SERIES

Digital Control Panel



940-DCP Digital Control Panel

The 940-DCP features six programmable function switches, integrated siren controls and four progressive mode switches allowing Jump To Mode™ activation as well as a traffic direction switch for use with TOMAR LED or NEOBE® lightbars equipped with the traffic direction option. The 940-DCP is backlit with LED indicators for easy identification and features a spill resistant housing. Connections are made via a simple RJ45 connection to the lightbar or 940 Siren Amp. All switches are a durable magnetic touch pad rated for 10 million operations.



940-SIREN Control Panel and Siren Amplifier

The 940-SIREN combines the 940-DCP Digital Control Panel and the 940-AMP Siren Amplifier into a single unit for simplified installation.

Ordering Information

Model No.	Description
940L-DCP	Digital control panel for use with any Tomar Lightbar, Traffic Advisor, Lstick and all Auxiliary lighting
940N-DCP	Digital control panel for use with 930N series lightbars

Specifications

Item	Description
Dimensions	7" x 3.6" x 9.0" x 0.65 lbs (178mm x 92mm x 228.6mm x 0.29kg) model 940-DCP

CONTROLLERS AND SIRENS

940-AMP Siren Amplifier

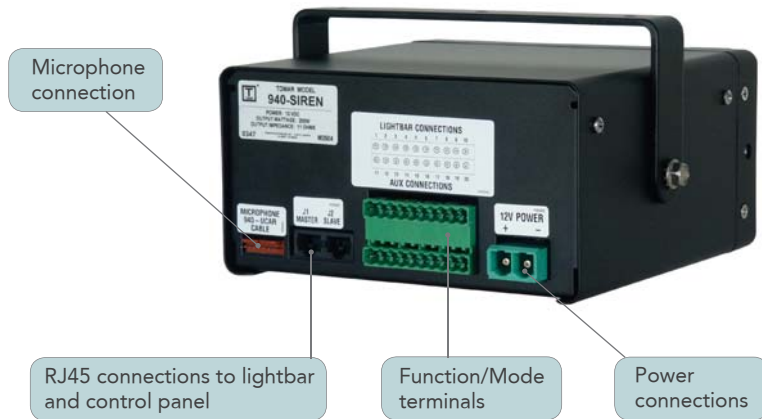

(installed view)

940-AMP Siren Amplifier

The 940-AMP features 200 watt maximum load with one or two drivers, auxiliary connections for Horn Ring, Horn Relay, Air Horn, Park Kill and Alarm, seven selectable siren tones and a simple RJ45 connection to lightbar or 940-DCP.

Ordering Information

Model No.	Description
940-AMP	Siren amplifier
948L-DCP	Digital control panel for use with any Tomar Lightbar, Traffic Advisor, Lstick and all Auxiliary lighting
940L-DCP	Digital control panel for use with any Tomar Lightbar, Traffic Advisor, Lstick and all Auxiliary lighting
940N-DCP	Digital control panel for use with 930N series lightbars
940L-SIREN	Digital control panel and siren amplifier mounted together as a single unit. For use with use with any Tomar Lightbar, Traffic Advisor, Lstick and all Auxiliary lighting
940N-SIREN	Digital control panel and siren amplifier mounted together as a single unit. For use with 930N and 930NH series lightbars.
940L-SIREN-R	Digital control panel and siren amplifier shipped as separate pieces with 20' cables for remote mounting applications. For use with use with any Tomar Lightbar, Traffic Advisor, Lstick and all Auxiliary lighting
940N-SIREN-R	Digital control panel and siren amplifier shipped as separate pieces with 20' cables for remote mounting applications. For use with 930N and 930NH series lightbars.
940-M3473	Hand held microphone for use with all 940 amplifier or siren systems. (This option is included when ordering either 940-AMP or 940-SIREN systems.)

Specifications

Item	Description
Dimensions	7" x 3.6" x 9.0" x 0.65 lbs (178mm x 92mm x 228.6mm x 0.29kg) model 940-DCP 7" x 3.6" x 5.9" x 4.35 lbs. (178mm x 92mm x 149.86mm x 1.97kg) model 940-AMP 7" x 5.0" x 6.8" x 5.0 lbs. (178mm x 173mm x 172.72mm x 2.27kg) model 940-SIREN

943 DIGITAL SWITCH BOX



943-SB Switch Box

The 943 Switch Box is a compact, programmable, full function lighting controller featuring two warning mode switches, two programmable auxiliary switches, a step through arrow switch, a dedicated dim switch that can be used as a third auxiliary switch and a progressive system off switch. The switch panel incorporates LED backlighting and LED switch indicator lights for easy day or night readability. A six LED indicator panel provides visual indication of warning mode, left arrow, right arrow or center out activation. Each switch is rated for 5 amps with a system total of 12 amps. An optional universal mounting bracket is available.

- Arrow function button
- Two mode switches provide up to three unique flash patterns
- Two independent auxiliary switches
- LED indicator for directional arrow and warning modes
- LED backlighting for night time visibility



Shown with 943-MTGBKT
Universal mounting bracket

Ordering Information

Model No.	Description
943-SB	Digital Switch Box
943-MTGBKT	Universal mounting bracket

Specifications

Item	Description
943-BP Dimensions	5.625"x2.625"x1" (142mm x 66mm x 25mm)
Operating Temperature Range	-55°C to +65°C
Input Voltage Range	12 VDC
Output	Each switch is rated at 5A, combined current not to exceed 12A



DRV100

Siren and Warning Driver

- police vehicles
- fire and rescue vehicles
- industrial environments

The DRV100 is constructed with a self-aligning sound chamber assembly containing 2.625" phenolic diaphragm. The speaker is driven by a copper-clad aluminum high-temperature voice coil with a polyimide/glass composite former. The magnet structure is highly efficient and light weight. The finish is a light-texture black powder coat for durability and environmental stability. The magnet structure is first coated with a Mil-Spec "E-Coat" for additional protection. Front mounting 1/4"-20 threaded and 5/16"-18 rear holes are provided to allow the driver to utilize industry standard mounting brackets and accessories. Electrical connection is made via standard slip-on terminals. The DRV100 is compatible with most 11 ohm/100W siren amplifiers.

Ordering Information

Model No.	Description
DRV100	Siren and warning driver

Specifications

Item	Description
Power Rating	100 watt RMS
Plane Wave Frequency Response	250-3600Hz ± 5dB
Sound Level (Peak dBA)	116dB average
Nominal Impedance	11 Ohms
DCR	6 Ohms
Size and Weight	4.6" dia. x 3" tall x 5.4 lbs (117mm x 76.2mm x 2.45kg)



SPK100 Slimline Speaker

- police vehicles
- fire and rescue vehicles
- industrial environments

The SPK100 Slimline speaker is 100 watts and designed for use in emergency vehicles, security alarm, public safety, and 2-way radio systems. The two-piece aluminum bell houses the driver and provides complete weather and corrosion protection for all internal components. The exponential flare rate of the horn optimizes sound dispersion at any power level in a 75° pattern. Neodymium magnet, ferrofluid cool.

Ordering Information

Model No.	Description
SPK100	Slimline speaker

Specifications

Item	Description
Power Rating	100 watt RMS
Impedance	11 Ohms
Frequency Response	700–2700Hz
Sound Level (Peak dBA)	112 dBA (measured 1W/1M) 118 dBA (measured at rated power, 3 meters)
Dispersion (2000Hz octave band, 6dB points)	75°
Finish	Black
Size and Weight	6.625" dia. x 2.25" deep x 12 lbs (170mm x 60mm x 5.44kg)



- police vehicles
- fire and rescue vehicles
- industrial environments

SPK200 SPEAKER

The SPK200 speaker is 100 watts and designed for use in emergency vehicles, security alarm, public safety, and 2-way radio systems.

Ordering Information

Model No.	Description
SPK200	Speaker

Specifications

Item	Description
Power Rating	100 watt RMS
Plane Wave Frequency Response	250-3600Hz \pm 5dB
Sound Level (Peak dBA)	116dB average
Nominal Impedance	11 Ohms
DCR	6 Ohms
Size and Weight	6" x 5.5" dia. (152mm x 140mm)



- police vehicles
- fire and rescue vehicles
- industrial environments

SPK300 SPEAKER

The SPK300 speaker is 100 watts and designed for use in emergency vehicles, security alarm, public safety, and 2-way radio systems.

Ordering Information

Model No.	Description
SPK300	Speaker, Aluminum
SPK300-B	Speaker, Black finish

Specifications

Item	Description
Power Rating	100 watt RMS
Plane Wave Frequency Response	250-3600Hz ± 5dB
Sound Level (Peak dBA)	116dB average
Nominal Impedance	11 Ohms
DCR	6 Ohms
Size and Weight	5.25" tall x 6.25" x 3.125" (130.2mm x 155.5mm x 79.4mm)

SALES OFFICES

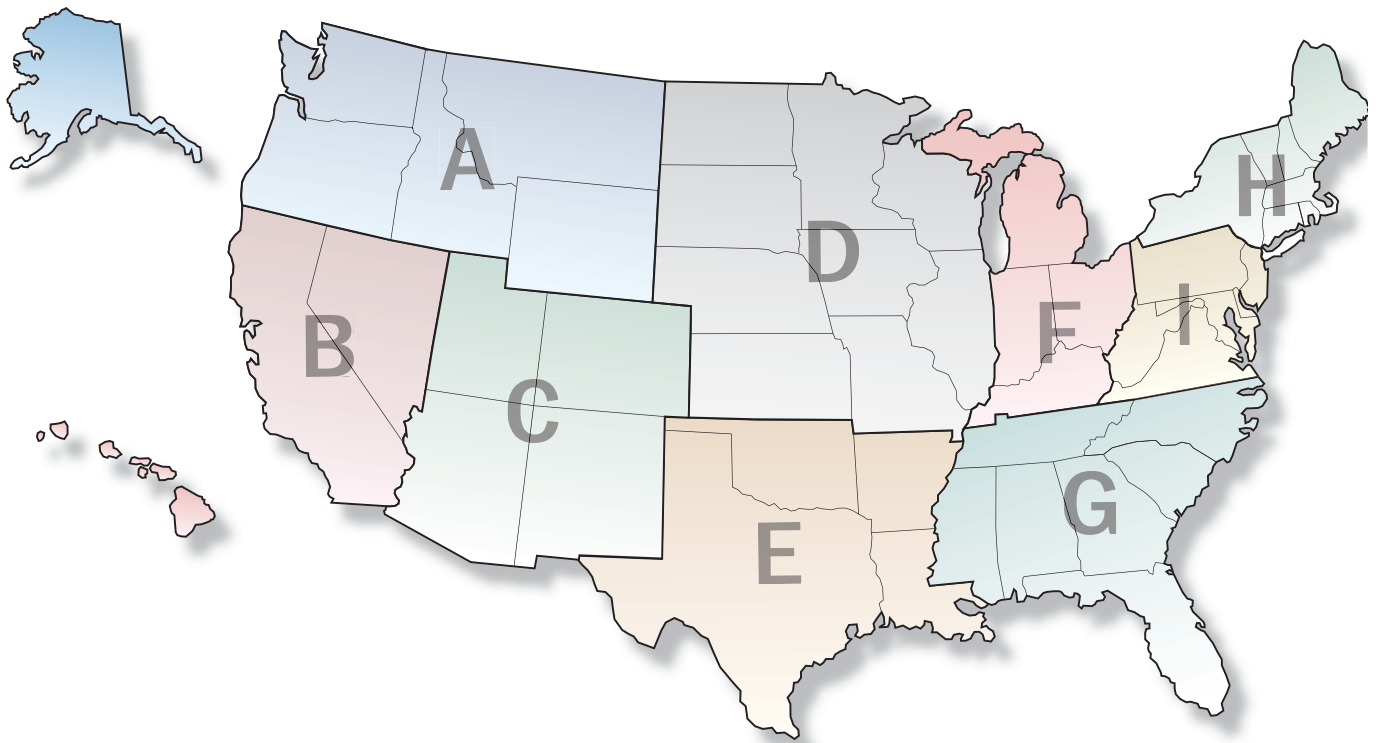

Territory A	Territory B	Territory C	Territory D	Territory E
Alaska, Idaho, Montana, Oregon, Washington, Wyoming	California, Hawaii, North Nevada	Arizona, Colorado, Southern Nevada, New Mexico	Kansas, Nebraska, North & South Dakota, Illinois, Iowa, Minnesota, Missouri, Wisconsin	Arkansas, Louisiana, Oklahoma, Texas
Scott Cooke 604.866.6514 cell 604.5744055 fax scott.cooke@tomar.com	Matt Barker 480.399.3055 matt.barker@tomar.com	Tom Bleasdale 602.524.0521 480.585.2971 fax tomb@tomar.com Larry Mades 480.236.2709 480.585.2971 fax larry.mades@tomar.com	James Rameker 608.236.0329 608.236.0331 fax jamesr@tomar.com	Dan Sides 972.743.8555 877.575.9598 fax dan.sides@tpmar.com

Territory F	Territory G	Territory H	Territory I
Indiana, Kentucky, Michigan, Ohio	Alabama, Florida, Georgia, Mississippi, North Carolina, South Carolina, Tennessee	Connecticut, Maine, Massachusetts, New Hampshire, New York, Rhode Island, Vermont	Delaware, Maryland, New Jersey, Pennsylvania, Virginia, West Virginia
Steve Taylor 260.760.5354 steve.taylor@tomar.com	Stuart Johnston 904.608.5607 904.608.7908 fax stuartj@tomar.com	Walter Willems III 631.521.9877 800.688.6627 fax walter.willems@tomar.com	Bob Pfaff 215.806.4101 215.766.7481 fax bob.pfaff@tomar.com

TOMAR Electronics, Inc.
Clearing the Way

TOMAR WARRANTY

Except for Xenon strobe lamps and incandescent lamps, TOMAR Electronics, Inc. warrants most products described herein for a period of 2 years under normal use and service from the date of purchase as marked on the product, that the product will be free of defects in material and workmanship. This warranty does not cover ordinary wear and tear, abuse, misuse, overloading, altered products, or damage caused by the purchaser connecting the unit to wrong voltage or polarity. Xenon strobe lamps are warranted for 1 full year from date of purchase.

THERE IS NO WARRANTY OF MERCHANTABILITY. THERE ARE NO WARRANTIES THAT EXTEND BEYOND THE DESCRIPTION HEREIN. THERE ARE NO WARRANTIES EXPRESSED OR IMPLIED OR ANY AFFIRMATION OF FACT OR REPRESENTATION EXCEPT AS SET FORTH HEREIN.

REMEDY

TOMAR Electronics, Inc.'s sole responsibility and liability, and purchaser's exclusive remedy shall be limited to the repair or replacement at TOMAR Electronics, Inc.'s option, of a part or parts not conforming to the warranty. All products requiring warranty service shall be returned to TOMAR Electronics, Inc. within the warranted period, shipping prepaid. TOMAR Electronics, Inc. will return repaired or replaced products to the purchaser via prepaid ground transportation. In no event shall TOMAR Electronics, Inc. be liable for damages of any nature, including incidental or consequential damages, including but not limited to any damages resulting from non-conformity, defect in material or workmanship

All material being returned for service must have an RMA number shown on the shipping label. Please write or call 1 (800) 338-3133 to obtain the RMA number prior to sending the material for service.



TOMAR Electronics, Inc.

2100 W. Obispo Ave. Gilbert, AZ 85233 USA 800.338.3133 phone 800.688.6627 fax