



STREET
HIGHWAYS
FLOOD
AMENITY
BOLLARD
HANDRAIL
SURVEILLANCE
SUBWAY
CANOPY
PERIMETER
SECURITY
TUNNEL
LOW LEVEL
HIGH MAST
RAIL

ELITE EXTERIOR LIGHTING COLLECTION



MINI HIGHWAY DIAMOND™ ELITE
See page 20-21

Bespoke orange Mini Highway Diamond™ Elite installed in central London, outside the Tate Modern.

DISCOVER YOUR LED LIGHTING...

FOR ALL YOUR EXTERIOR LED LIGHTING PROJECT REQUIREMENTS, THERE IS A SOLUTION FOR YOU.

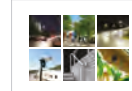

ELITE LIGHTING GALLERY

BROWSE THROUGH IMAGES OF OUR ELITE LUMINAIRES

2 - 15



HIGHWAY DIAMOND™ ELITE

A COMPLETE FAMILY OF LUMINAIRES IDEAL FOR ANYTHING FROM A FOOTPATH, TO A MOTORWAY

16 - 25



SMARTWATCH™

LUMINAIRE INTEGRATED SECURITY & SURVEILLANCE CAMERAS

26 - 29



ENSŌ™ COLLECTION

360° LED LIGHTING COLLECTION OF AMENITY LUMINAIRES

30 - 35



STEALTH ELITE

A ROBUST HIGH PERFORMANCE EXTERIOR WALL MOUNTED LUMINAIRE

36 - 37



LITEHOUSE BOLLARD

A STYLISH ROOT OR SURFACE MOUNTED BOLLARD IDEAL FOR DEFINING ROUTES

38 - 39



VIPERRAIL™

A STYLISH YET FUNCTIONAL LED ILLUMINATED HANDRAIL SYSTEM

40 - 41



INVINCIBLE

A ROBUST CORNICE LUMINAIRE SUITABLE FOR SUBWAYS, HIGH DEPENDENCY AND SECURITY

42 - 43



TITAN

HIGH EFFICIENCY ANTI-VANDAL LUMINAIRE, SUITABLE FOR EXTERNAL SUBWAYS & PUBLIC WALKWAYS

44 - 45

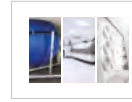

ASD LIGHTING

CHECK OUT SOME OF OUR LATEST FACILITIES.

46 - 53



**MAXI HIGHWAY
DIAMOND™ ELITE**
See page 24-25



Windy Harbour,
Blackpool



Quality



Manufacturing



Green



Efficient



Low Carbon



Social Value



Reduced
Transportation



CE Mark



London Borough of Southwark.



**MINI HIGHWAY
DIAMOND™ ELITE**
See page 20-21

**MICRO HIGHWAY
DIAMOND™ ELITE**
See page 18-19



SMARTWATCH™ PTZ CAMERA

Pan-tilt-zoom camera integrated in
the Midi Highway Diamond™ Elite.
See page 26-28





**STEALTH ELITE
WALLPACK**
See page 36-37



**SMARTWATCH™
DISCREET CAMERA**
See page 26-29

ENSŌ
See page
30-35



Rotherham Town
Centre

**SMARTWATCH™ BULLET
CAMERA WITH
CONNECTED AUDIO
SEE PAGE 26-29**



LITEHOUSE BOLLARD
See page 38-39



New York
Stadium



Manchester

**VIPERRAIL™ ILLUMINATED
HANDRAIL SYSTEM**
SEE PAGE 40-41

INVINCIBLE LED
SEE PAGE 42-43



Wonderpass Subway,
London

TITAN LED
SEE PAGE 44-45

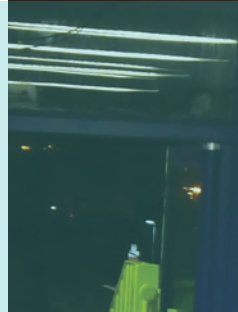

Hornsey Railway
Station



Solihull

**STEALTH ELITE
WALLPACK**
See page 36-37



ENSÖ
See page 30-35

Kyrkjevegen Bridge,
Bergen, Norway



**MINI HIGHWAY
DIAMOND™ ELITE**
See page 20-21

New Build Housing,
Saltburn-by-the-Sea

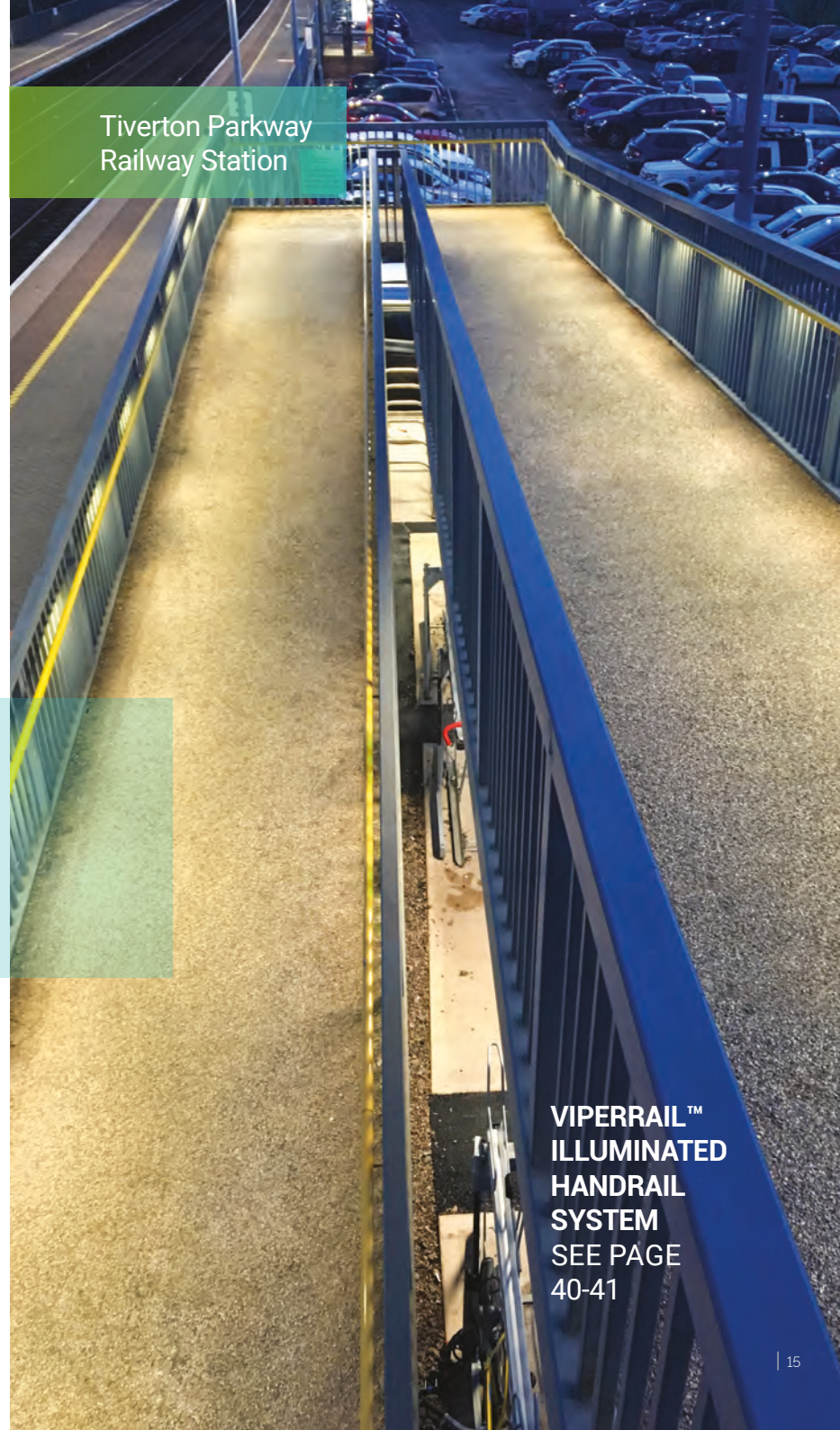

Tiverton Parkway
Railway Station

**VIPERRAIL™
ILLUMINATED
HANDRAIL
SYSTEM**
SEE PAGE
40-41



The Highway Diamond™ Elite range by ASD Lighting offers a complete family of luminaires with an unsurpassed flexibility of lumen outputs, optical distributions and specification features.

It is suitable for use in a multitude of locations, from rural villages through to modern 24 hour smart cities, main roads, motorways and infrastructure projects.

Four body sizes with modern sympathetic styling to ensure architects, planners and designers can follow an integrated design with a homogenous family of luminaires.

- UK Manufactured.
- High Specification.
- High Efficacy.
- Tool Free Access.
- IP66.
- IK10.
- CE.
- ENEC.
- 10 Day Delivery.





Technical Data	Standard Features	Additional Detail
LED	✓	Designed solely for an LED light source
Driver	✓	DALI Programmable, CMS Compatible
Driver Current	Various	200 - 700 mA
Dimming	✓	Multiple Step / Part Night
Constant Light Output	✓	
Photometric Lens Options	✓ (Multiple)	Inc. Narrow / Medium / Wide / Extra Wide / Pedestrian Crossing
Luminaire Materials	LM6 Marine Grade Die-Cast Aluminium	Housing / Spigot / Fixing Clip
RAL Colours	Black / Light Grey	RAL 9005 / 9006
Correlated Colour Temperature	Various	Warm White / Neutral White / Cool White
Colour Rendering	> 80 > 72	Warm White Neutral White / Cool White
Ingress Protection Rating	IP66	Gear & LED Compartments
Impact Protection Rating	IK10	Optical Cover
Optical Cover	✓ Flat Cover	UV Stable Polycarbonate
Entry to Gear Compartment	Tool Free	Simple fixing clip
Driver Gear Tray Replacement	Tool Free (Excluding Micro Highway Diamond™)	Completely replaceable without tools required
Inbuilt Anti-Tamper Facility	✓	Instructions provided in the luminaire
Protection Class	Class 1	
Warranty Period	Standard 5 Years	Extended Warranties Available
Specification	✓ (Various)	Inc. CE Certification / ENEC Mark
Design Life	100,000 hr	> L90, < F10
Mains Voltage	220-240 V / 50-60 Hz	
Operating Temperature Range	-40 to +55°C	Based on ambient external temperature
Surge Protection	Inbuilt Driver	10 kV (1 pulse) / 8 kV
Vibration Tested	✓	Certificates - EN 60068-2-6 & EN 60068-2-64
Manufacturing Location	UK	



Footpath



Residential



Cycle Routes



Car Parks



Traffic Routes



Pedestrian



Rail



Infrastructure



Motorway

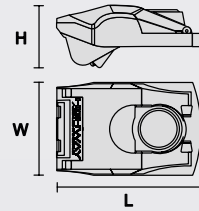

Size	
Length	255mm
Width	165mm
Height	111mm

Technical Data

LED Configuration	4 / 8 / 12 / 16
System power watts	4 - 37 W
Delivered lumens	300 - 4000 lm
Weight (Excluding Spigot)	3.1kg
Weight (Including Spigot)	3.5kg
Windage	< 0.02m ²
Mounting Options	Post Top (Ø 76 mm - Ø 60 mm) Side Entry (Ø 76 mm - Ø 60 mm) Side Entry (Ø 42 mm - Ø 28 mm)
Tilt - Post Top	0° / 5° / 10° / 15°
Tilt - Side Entry	-10° / -5° / 0° / 5° / 10°

All features previously listed in the Highway Diamond™ Elite Range (pages 16 & 17) apply to this product.

The Micro Highway Diamond™ is the smallest luminaire in the family. It is a high specification, high efficacy, UK manufactured luminaire delivering up to approximately 4,000 lumens.



4 LED

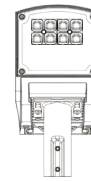

8 LED

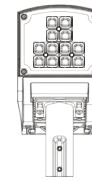

12 LED

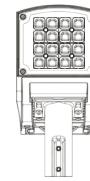

16 LED





Bradford

Code Builder	
HWD2/ HWD2P/ HWD2S/	60 - 76mm spigot 60 - 76mm (Set as post top pre-wired only) 28 - 42mm spigot
Colour Finish	
B J	Black (RAL 9005) Light Grey (RAL 9006)
Correlated Colour Temperature	
3 4 57	3000K 4000K 5700K
LED Quantity	
LED4 LED8 LED12 LED16	4 LED 8 LED 12 LED 16 LED
Drive Current (200 - 700mA)	
20 30 35 40 50 60 70	200mA 300mA 350mA 400mA 500mA 600mA 700mA
Switching (Only if requested)	
C NS 7NS	Mini Cell NEMA Socket 7 Pin NEMA Socket Other switching systems available on request. NFC driver available on request.
Optics	
-S4 As above Insert optic code required	S4 Optic S0 / S1 / S2 / S3 / S5 / S6 / S7 / S8 / M1 / M2 / M3 / M4 / M5 / M6 / M7 / M8 / F0 / F1 / F2 / F3 / F4 / A1 / A2 / A3 / A4 / A5
Pre-wired (Only if requested)	
W8 2W8	8 metre Pre-wired 3 core flex (1.5mm) 8 metre Pre-wired 3 core flex (2.5mm)

Code Example

HWD2/B4LED835C-S1-W8

Micro Highway Diamond™ Elite 60-76mm spigot, Black Finish, 4000K, 8 LED, 350mA, Mini Cell, S1 Optic, 8m Pre-wired 1.5mm flex.

MINI HIGHWAY DIAMOND™ ELITE

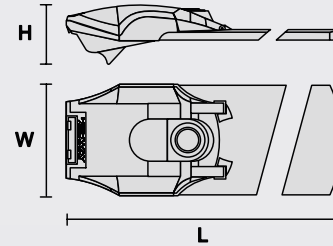

Size

Length	476mm
Width	233mm
Height	116mm

Technical Data

LED Configuration	4 / 8 / 12 / 16 / 20 / 24 / 28 / 32 / 36 / 40 / 44
System power watts	4 - 95 W
Delivered lumens	300 - 11044 lm
Weight (Excluding Spigot)	4.27kg (4 - 16 LED) 4.47kg (16 - 44 LED)
Weight (Including Spigot)	4.57kg (4 - 16 LED) 4.97kg (16 - 44 LED)
Windage	< 0.04m ²
Mounting Options	Post Top (Ø 76 mm - Ø 60 mm) Side Entry (Ø 76 mm - Ø 60 mm) Side Entry (Ø 42 mm - Ø 28 mm)
Tilt - Post Top	0° / 5° / 10° / 15°
Tilt - Side Entry	-10° / -5° / 0° / 5° / 10°

All features previously listed in the Highway Diamond™ Elite Range (pages 16 & 17) apply to this product.

The Mini Highway Diamond™ is the original luminaire in the family. It is a high specification, high efficacy, UK manufactured luminaire delivering up to 11,000 lumens.



4 LED



8 LED



12 LED

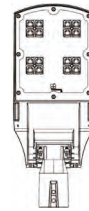

16 LED

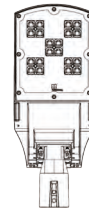

20 LED

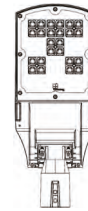

24 LED

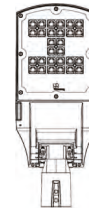

28 LED

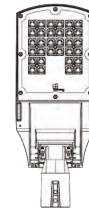

32 LED



36 LED

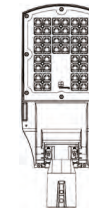

40 LED

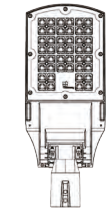

44 LED

A London University Campus Road



Code Builder

HWDP/ HWDP/ HWDS/	60 - 76mm spigot 60 - 76mm (Set as post top pre-wired only) 28 - 42mm spigot
-------------------------	--

Colour Finish

B	Black (RAL 9005)
J	Light Grey (RAL 9006)

Correlated Colour Temperature

3	3000K
4	4000K
57	5700K

LED Quantity

LED4	4 LED
LED8	8 LED
LED12	12 LED
LED16	16 LED
LED20	20 LED
LED24	24 LED
LED28	28 LED
LED32	32 LED
LED36	36 LED
LED40	40 LED
LED44	44 LED

Drive Current (200 - 700mA)

20	200mA
30	300mA
35	350mA
40	400mA
50	500mA
60	600mA
70	700mA

Switching (Only if requested)

C	Mini Cell
NS	NEMA Socket
7NS	7 Pin NEMA Socket
	Other switching systems available on request.
	NFC driver available on request.

Optics

-S4	S4 Optic
As above Insert optic code required	S0 / S1 / S2 / S3 / S5 / S6 / S7 / S8 / M1 / M2 / M3 / M4 / M5 / M6 / M7 / M8 / F0 / F1 / F2 / F3 / F4 / A1 / A2 / A3 / A4 / A5

Pre-wired (Only if requested)

W8	8 metre Pre-wired 3 core flex (1.5mm)
2W8	8 metre Pre-wired 3 core flex (2.5mm)

Code Example

HWDP/B4LED835C-S1-W8

Mini Highway Diamond™ Elite 60-76mm spigot, Black Finish, 4000K, 8 LED, 350mA, Mini Cell, S1 Optic, 8m Pre-wired 1.5mm flex.

For more detailed specifications & code, contact ASD Lighting.

MIDI HIGHWAY DIAMOND™ ELITE

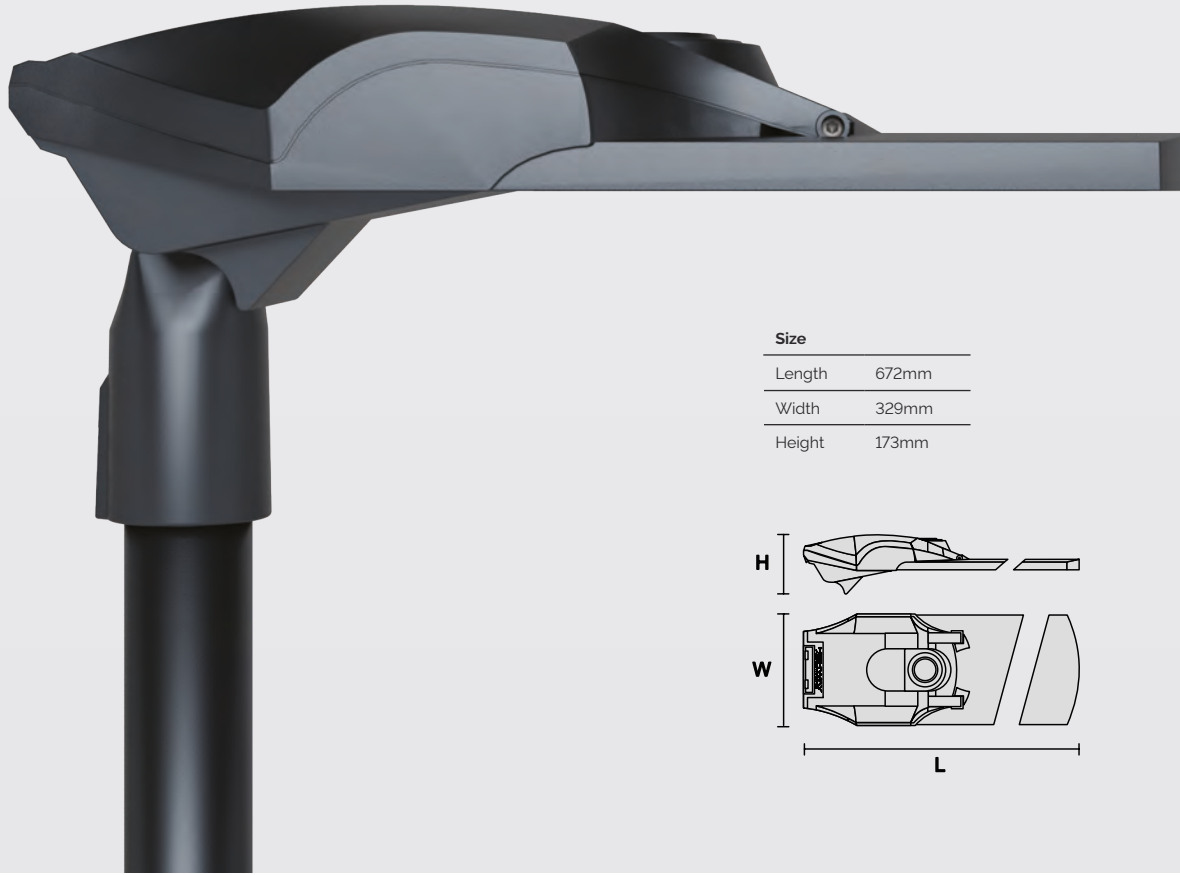

Size	
Length	672mm
Width	329mm
Height	173mm

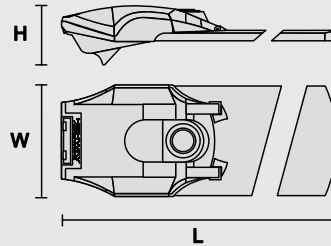

Technical Data

LED Configuration	44 / 52 / 60 / 68 / 76 / 84 / 92 / 100
System power watts	48 – 211 W
Delivered lumens	4,832 - 24,341 lm
Weight (Excluding Spigot)	< 11.5kg (44 – 100 LED*)
Weight (Including Spigot)	< 12.5kg (44 – 100 LED*)
Windage	< 0.11m ²
Mounting Options	Post Top (Ø 76 mm - Ø 60 mm) Side Entry (Ø 76 mm - Ø 60 mm) Side Entry (Ø 42 mm - Ø 28 mm)
Tilt - Post Top	-5° / 0° / 5° / 10° / 15°
Tilt - Side Entry	-10° / -5° / 0° / 5° / 10° / 15°
Auto Disconnect	✓ Switches unit off upon opening

All features previously listed in the Highway Diamond™ Elite Range (pages 16 & 17) apply to this product.

*Weight varies dependent on driver configuration.

The Midi Highway Diamond™ is a new edition to the Highway Diamond™ Elite range with enhanced high specification features. It is a high efficacy, UK manufactured luminaire delivering up to 25,000 lumens.

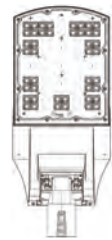

44 LED



52 LED



60 LED



68 LED



76 LED



84 LED



92 LED



100 LED

Car park,
Cleckheaton



Code Builder	
HWD6/ HWDP6/	60 - 76mm spigot 60 - 76mm (Set as post top pre-wired only)
Colour Finish	
B J	Black (RAL 9005) Light Grey (RAL 9006)
Correlated Colour Temperature	
3K 4K 57K	3000K 4000K 5700K
LED Quantity	
44 52 60 68 76 84 92 100	44 LED 52 LED 60 LED 68 LED 76 LED 84 LED 92 LED 100 LED
Drive Current (200 - 700mA)	
20 30 35 40 50 60 70	200mA 300mA 350mA 400mA 500mA 600mA 700mA
Switching (Only if requested)	
C NS 7NS	Mini Cell NEMA Socket 7 Pin NEMA Socket Other switching systems available on request. NFC driver available on request.
Optics	
-S4 As above Insert optic code required	S4 Optic S0 / S1 / S2 / S3 / S5 / S6 / S7 / S8 / M1 / M2 / M3 / M4 / M5 / M6 / M7 / M8 / F0 / F1 / F2 / F3 / F4 / A1 / A2 / A3 / A4 / A5
Pre-wired (Only if requested)	
W10 2W10	10 metre Pre-wired 3 core flex (1.5mm) 10 metre Pre-wired 3 core flex (2.5mm)

Code Example

HWD6/B4K6850-M1-W10

Midi Highway Diamond™ Elite 60-76mm Spigot, Black Finish, 4000K, 68 LED, 500mA, M1 Optic, 10m Pre-wired 1.5mm flex.

For more detailed specifications & code, contact ASD Lighting.

MAXI HIGHWAY DIAMOND™ ELITE

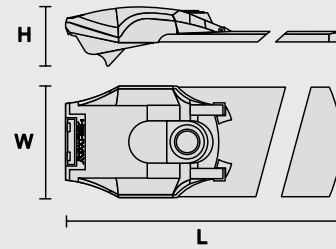
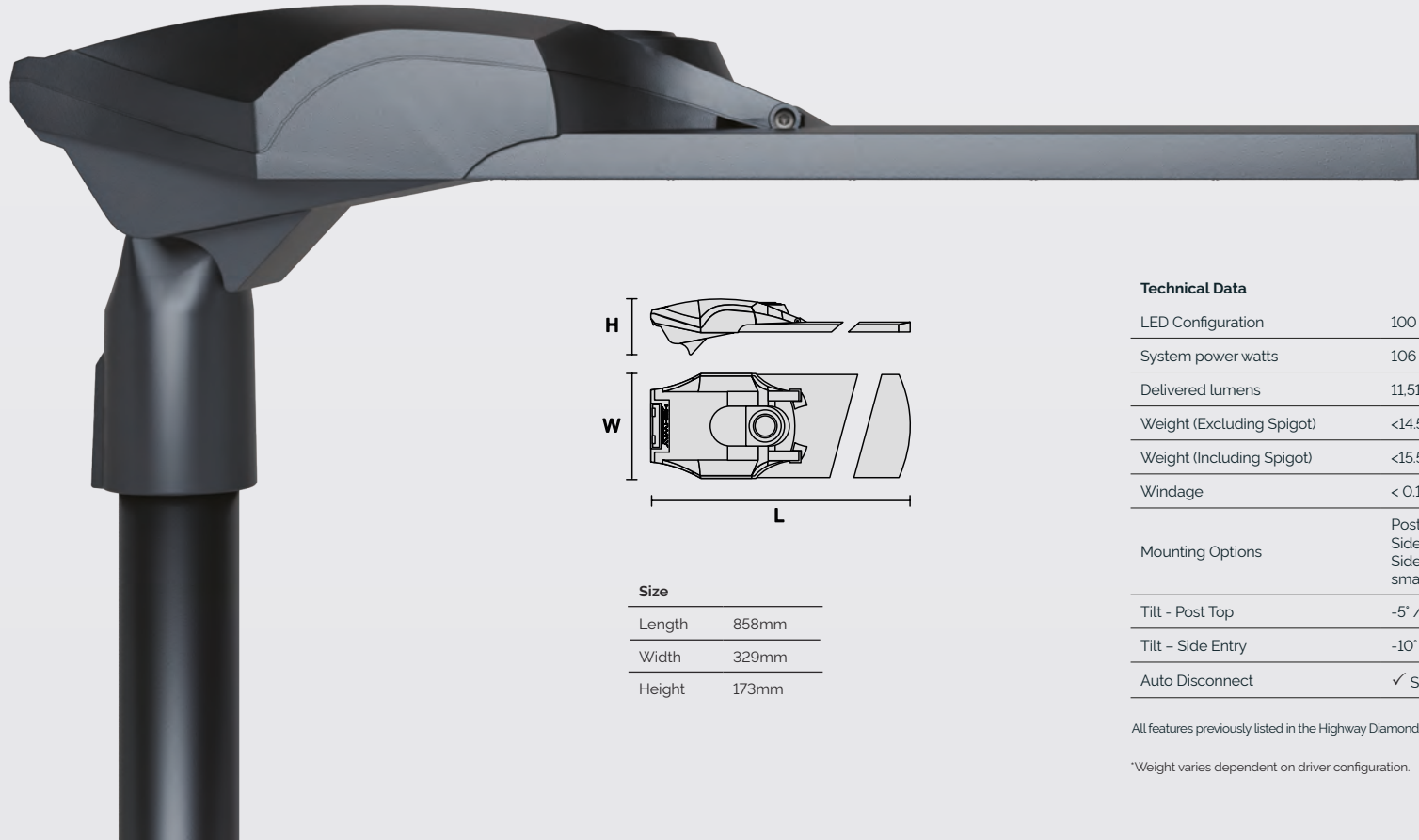

Size

Length	858mm
Width	329mm
Height	173mm

Technical Data

LED Configuration	100 / 112 / 124 / 136 / 148 / 160
System power watts	106 - 338 W
Delivered lumens	11,515 - 39,608 lm
Weight (Excluding Spigot)	<14.5kg (100 - 160 LED*)
Weight (Including Spigot)	<15.5kg (100 - 160 LED*)
Windage	< 0.12m ²
Mounting Options	Post Top (Ø 76 mm - Ø 60 mm) Side Entry (Ø 76 mm - Ø 60 mm) Side Entry (Insert reducers available for smaller diameters)
Tilt - Post Top	-5° / 0° / 5° / 10° / 15°
Tilt - Side Entry	-10° / -5° / 0° / 5° / 10° / 15°
Auto Disconnect	✓ Switches unit off upon opening

All features previously listed in the Highway Diamond Elite Range (pages 16 & 17) apply to this product.

*Weight varies dependent on driver configuration.

The Maxi Highway Diamond™ is the largest member of the Highway Diamond™ Elite family, with the same enhanced high specification features. It is a high efficacy, UK manufactured luminaire delivering up to 40,000 lumens.



100 LED



112 LED

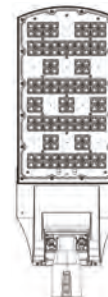

124 LED

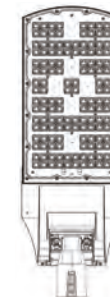

136 LED

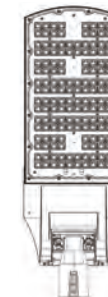

148 LED



160 LED



Windy Harbour,
Blackpool

Code Builder

HWDB/ HWDP8/	60 - 76mm spigot 60 - 76mm (Set as post top pre-wired only)
-----------------	--

Colour Finish

B	Black (RAL 9005)
J	Light Grey (RAL 9006)

Correlated Colour Temperature

3K	3000K
4K	4000K
57K	5700K

LED Quantity

100	100 LED
112	112 LED
124	124 LED
136	136 LED
148	148 LED
160	160 LED

Drive Current (200 - 700mA)

20	200mA
30	300mA
35	350mA
40	400mA
50	500mA
60	600mA
70	700mA

Switching (Only if requested)

C	Mini Cell
NS	NEMA Socket
7NS	7 Pin NEMA Socket
	Other switching systems available on request.
	NFC driver available on request.

Optics

-S4	S4 Optic
As above Insert optic code required	S0 / S1 / S2 / S3 / S5 / S6 / S7 / S8 / M1 / M2 / M3 / M4 / M5 / M6 / M7 / M8 / F0 / F1 / F2 / F3 / F4 / A1 / A2 / A3 / A4 / A5

Pre-wired (Only if requested)

W15	15 metre Pre-wired 3 core flex (1.5mm)
2W15	15 metre Pre-wired 3 core flex (2.5mm)

Code Example

HWDB/B4K16050-M1-W15

Maxi Highway Diamond™ Elite 60-76mm Spigot, Black Finish, 4000K, 160 LED, 500mA, M1 Optic, 15m Pre-wired 1.5mm flex.

For more detailed specifications & code, contact ASD Lighting.



Market leading, high specification, UK manufactured street lighting, combined with a global leading camera manufacturer.

ASD Lighting, does more than illuminate.

Following on from the great success of the Highway Diamond luminaire, ASD Lighting partnered with Axis communications to integrate their surveillance cameras into the Highway Diamond Elite Midi range of premium exterior luminaires.



- **Reduced Capital Cost** – By utilising the lighting columns and cabling it reduces the requirement for additional CCTV columns, trenching & cabling.
- **Retro-Fit ability** – Allows clients to add surveillance cameras in to locations where they do not currently have it without needing for an expensive re-wire or civils work.
- **No shadowing on images** – Because the light source is mounted in the same location as the camera, there is no shadowing on recorded images. Conventionally cameras and lighting would be mounted in different locations which would create issues with shadowing and poor facial pickup.
- **Connectivity** – The wide range of connectivity options that we have developed for the SmartWatch™ system really does create a solution for any application and budget.

- **Maintenance features** – With clever product design we have been able to offer additional maintenance benefits when integrating lighting and camera technology. The components within the luminaire head are separated on to separate gear trays, lighting components on one gear tray and camera components on a separate gear tray. Each gear tray is independently removable and replaceable meaning that for future maintenance, lighting contractors only need to touch the lighting gear tray and camera contractors only need to touch the camera gear tray.
- **Speed of deployment** – Deployment for new CCTV locations is days not weeks with SmartWatch™.
- **Planning** - No additional planning needed to install CCTV on existing column infrastructure. Planning would be need to install new columns.





Connectivity Options



Internal Storage
(all data stored on 128gb SD Card in the luminaire)



Hard Wired
(ethernet)



Wi-Fi
(accessed remotely within Wi-Fi Range)



4G / LTE
(accessed remotely from any location)

- Functionality** – This is where the SmartWatch™ system and Axis cameras come in to their own, offering additional functionality to clients on top of basic video surveillance. These are tailored solutions based around an individual clients requirements and intended uses. These tailored solutions would require commissioning and potential licensing costs. The below are some common examples but the possibilities are endless;

 - PIR function** – All camera versions can be used to replace a PIR and activate corridor function up and down when it detects movement. Eg. On Perimeter fences at armed forces bases.
 - ANPR (number plate recognition)** – All the cameras are capable of ANPR to detect number plates, useful for places like car parks for allowing access and also monitoring time on site etc.
 - Facial Recognition** – All of the cameras are capable of Facial Recognition to allow automatic access or alert to the presence of watch list individuals when detected.
 - People & Traffic counting** – All of the camera are capable of this function for statistical analysis or to adjust lighting levels dependent on level of traffic at any given time.
 - Temperature / Gritting** – A thermal camera that can be used to monitor the temperature of a surface eg. Roadway / car park. When the temperature hits a specified temperature it can send an automated alert. Eg. When a road surface hits 4°C it can send an automatic notification to a gritting contractor to grit the car park. This has the potential to significantly reduce the liability to end users from accident claims on ice.
 - Listening Function** – A specialist camera that can be used with inbuilt microphone to listen for keywords or noises such as gun shots or screaming. Can be programmed to send automatic alerts upon detection.



- Flexible, rugged design outdoor use.
- Fixed lens with 1080p resolution.
- Wide 113° horizontal field of view.
- WDR - Forensic Capture (with ASD Connection Hub).
- Up to 20,000 lumen output.

Discreet Camera	
Lens	Fixed
Resolution	1080p
Horizontal Field of view (in 1080p)	113° (per camera)
Vertical Field of view (in 1080p)	62° (per camera)
Dust Resistant	✓ (IP66)
Moisture Resistant	✓ (IP66)
Frame Rate	50/60 fps (50/60Hz)
Operating Temperature Range	-30°C to +55°C
Warranty	3 years
Wide Dynamic Range Enabled	✓ (with F44 unit)
Quad View	✓ (with F44 unit)
Zipstream	✓
Two Way Audio Enabled	✓
Alarm in-/outputs enabled	✓
Pan / Tilt / Zoom	×
Lightfinder	×
Speed Dry (rain removal)	×
Auto Image Stabilisation	×
Auto-Tracking	×



- Sharpdome technology.
- Speed Dry function.
- Lightfinder technology.
- Axis Zipstream technology.
- Pan performance 700° per second.
- Up to 22,000 lumen output.

PTZ Camera	
Lens	Adjustable
Resolution	720p
Horizontal Field of view (in 1080p)	58.3°-2.1°
Vertical Field of view (in 1080p)	34.9°-1.3°
Dust Resistant	✓ (IP66)
Moisture Resistant	✓ (IP66)
Frame Rate	up to 25/30fps or 50/60 fps (50/60Hz)
Operating Temperature Range	-40°C to +70°C
Warranty	3 years
Wide Dynamic Range Enabled	Dynamic Capture
Quad View	×
Zipstream	✓
Two Way Audio Enabled	×
Alarm in-/outputs enabled	×
Pan / Tilt / Zoom	"Pan 360° endless, 0.05°-700°/s Tilt +20 to -90°, 0.05°-500°/s Zoom 30 x optical, 12 x digital = total 360 x zoom"
Lightfinder	✓
Speed Dry (rain removal)	✓
Auto Image Stabilisation	✓
Auto-Tracking	✓



- HDTV 1080p/5 MP.
- P-Iris control.
- Remote zoom and focus.
- I/O ports and two-way audio.
- Outdoor-ready and IK10 vandal-resistance.
- Up to 22,000 lumen output.



- Lightfinder and WDR – Forensic Capture.
- Axis Zipstream technology.
- HDTV 1080p at up to 60 fps.
- Built-in IR LEDs with OptimizedIR, 20 meters (66 feet).
- I/O support and Edge Storage.
- Up to 22,000 lumen output.

Dome Camera

Lens	Adjustable
Resolution	1080p
Horizontal Field of view (in 1080p)	84°-30°
Vertical Field of view (in 1080p)	63°-22°
Dust Resistant	✓ (IP66)
Moisture Resistant	✓ (IP66)
Frame Rate	"2MP - 30fps / 3MP - 20fps / 5MP - 12fps"
Operating Temperature Range	-40°C to +55°C
Warranty	3 years
Wide Dynamic Range Enabled	✓
Quad View	x
Zipstream	✓
Two Way Audio Enabled	✓
Alarm in-/outputs enabled	✓
Pan / Tilt / Zoom	Digital
Lightfinder	x
Speed Dry (rain removal)	x
Auto Image Stabilisation	x
Auto-Tracking	✓

Bullet Camera

Lens	"Varifocal Remote focus"
Resolution	1080p
Horizontal Field of view (in 1080p)	96°-33°
Vertical Field of view (in 1080p)	50°-18°
Dust Resistant	✓ (IP66)
Moisture Resistant	✓ (IP66)
Frame Rate	50/60 fps (50/60Hz)
Operating Temperature Range	-30°C to +50°C
Warranty	3 years
Wide Dynamic Range Enabled	Forensic Capture
Quad View	x
Zipstream	✓
Two Way Audio Enabled	x
Alarm in-/outputs enabled	✓
Pan / Tilt / Zoom	Digital
Lightfinder	✓
Speed Dry (rain removal)	x
Auto Image Stabilisation	x
Auto-Tracking	x

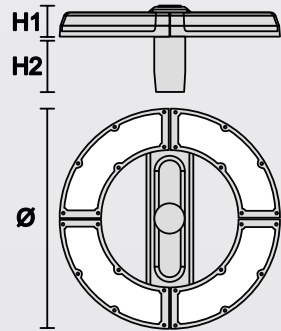

Size

Height 1 (head)	96mm
Height 2 (with spigot)	266mm
Diameter	670mm



- An extensive range of photometric distributions and customisable sections.
- Tool-less entry, auto-disconnect & quick release gear-tray features.
- Central or offset, post-top mounting. Suspension options also available.
- IP66 protection using bespoke poured gaskets.
- IK10+ impact resistance, marine grade, LM6 aluminium and polycarbonate body.
- 1000+ hours salt spray using environmentally friendly Metavate pre-treatment.
- Powder coat finish available in black, and white, and RAL9006.
- Maximum weight 13kg, including spigot.
- Windage (m²): 0.06.
- Mini Cell, Nema and PIR available.
- 3K, 4K and 5700K options.
- 5 year warranty.

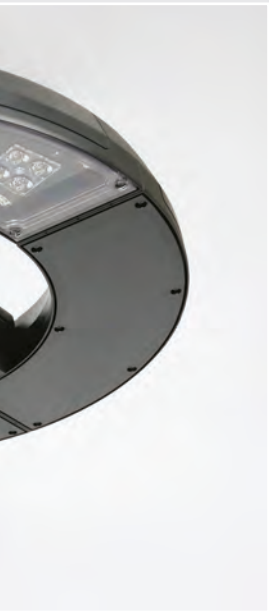
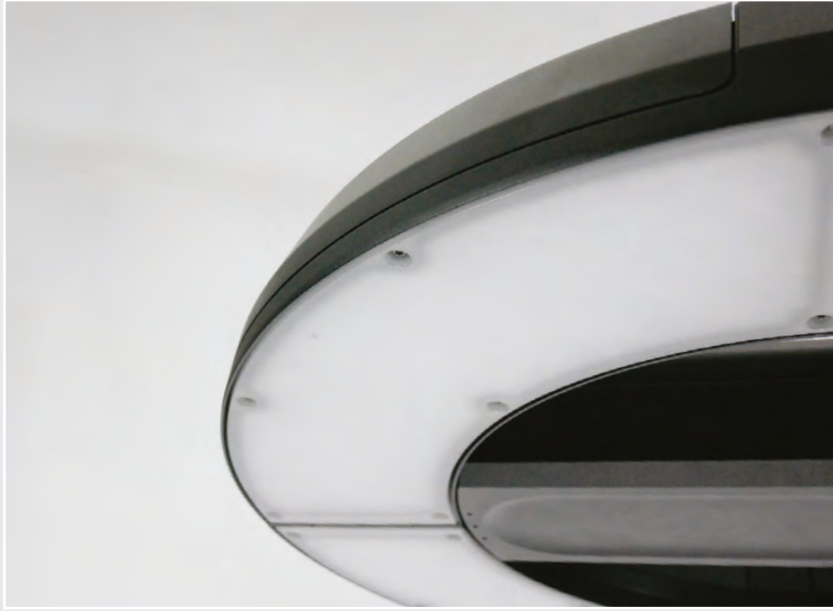



Configuration Examples

 Spigot Location



16 LED,
offset mount,
2 adjacent quadrants.



24 LED,
centre mount,
2 opposite quadrants.



40 LED,
offset mount,
1 adjacent quadrants.



32 LED,
4 quadrant.



48 LED,
4 quadrant.



80 LED,
4 quadrant.

Orientation & Optics



Symmetrical Orientation.

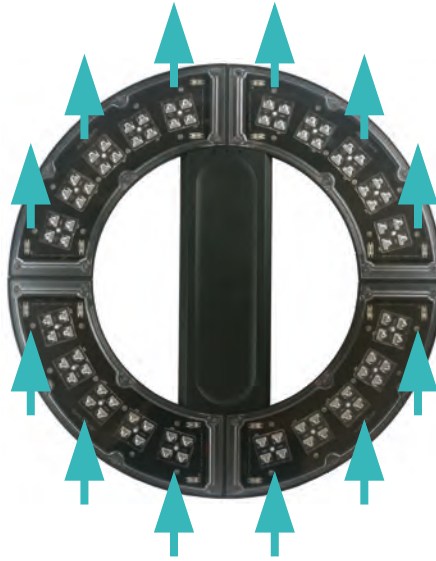

Asymmetrical Orientation.



Bisymmetrical Orientation.

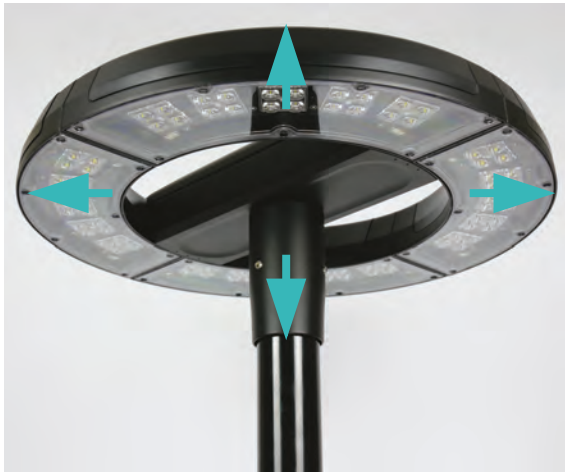

Symmetrical Distributions

A vast array of lens are available, and can be applied to the various orientations to provide tailored solutions. The examples below are common optics, in a symmetrical orientation.

A1 Optic

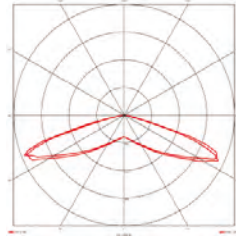
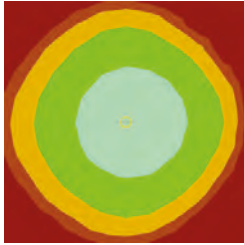

M1 Optic

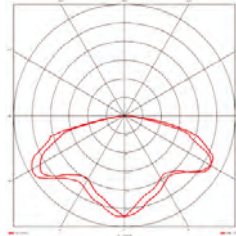
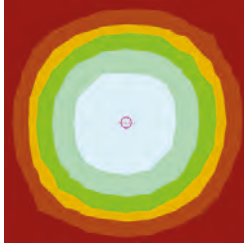

M2 Optic

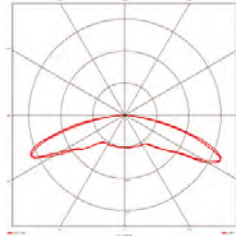
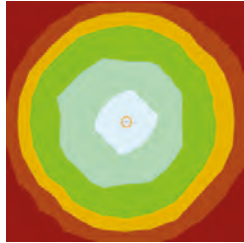

S0 Optic

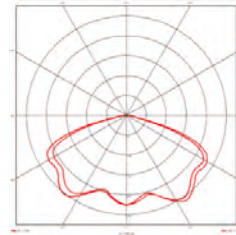
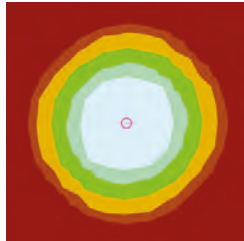

Code	
ENP	Post Top
Mounting	
C	Centre Mount
O	Offset Mount
Quadrants	
2Q	2 Quadrants
4Q	4 Quadrants
Configuration (2 Quadrants only)	
A	Adjacent Quadrants
O	Opposite Quadrants
Colour Finish	
B	Black
W	White
J	Light Grey
Correlated Colour Temperature	
3K	3000K
4K	4000K
57K	5700K
LED Quantity (Variable depending on Quadrant)	
LED16	16 LED (2Q)
LED24	24 LED (2Q)
LED32	32 LED (4Q)
LED40	40 LED (2Q)
LED48	48 LED (4Q)
LED80	80 LED (4Q)
Drive Current (Variable depending on LED Quantity)	
50	500mA
60	600mA
70	700mA
Switching (Only if requested)	
NS	3 Pin NEMA Socket
7NS	7 Pin NEMA Socket
C	Photocell
P	PIR
Lens Orientation	
B	Bi-Symmetrical
A	Asymmetrical
S	Symmetrical
Optics	
-S0	S4 Optic
-S1	S1 Optic
-A1	A1 Optic
-M1	M1 Optic
-M2	M2 Optic
Pre-wired (Only if requested)	
-W5	5 metre pre-wired
-W6	6 metre pre-wired
-W10	10 metre pre-wired

Code Example

ENPO2QA/B4K4060NS-BS1-W5

Ensö Offset Mount, 2 Quadrant Adjacent, Black Finish, 4000K, Clear Diffuser, 40 LED, 600mA, NEMA Socket, Bi-Symmetrical S1 Optic, 5 metre pre-wired.

For more detailed specifications & code, contact ASD Lighting.

STEALTH ELITE

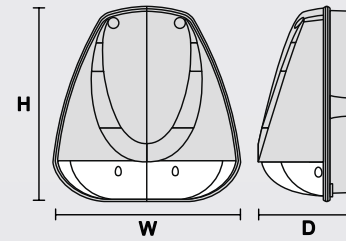

Size	
Width	330mm
Height	343mm
Depth	176mm

- Wall mount.
- Black and titanium colour finishes available.
- Flood, wide and T beam angle distribution available.
- Die cast aluminium (powder coated).
- Clear / opal diffuser options.
- DALI Driver as standard (requires different wiring than standard product in order to use DALI).
- 10KV Surge Protection.
- Integrated Over Voltage Protection.
- Standby Power less than 0.5W.
- High operation temperature version available.
- ULOR as low as 0.6%.
- Standard specification paint finish passes 1000 hours Salt Spray Test in accordance with BS EN ISO 9227:2006.
- > 100k hrs L90-B10.
- Latest generation of LED chips.
- IP65 / IK10.
- 5 Year LED guarantee.
- Emergency option available.
- PIR / Photocell options available.
- 3000 K available on request.
- Step Dim (Additional PIR required).
- Astro Dim (Additional Photocell required).
- Presence Detection (Additional PIR required).





Flood Beam Angle

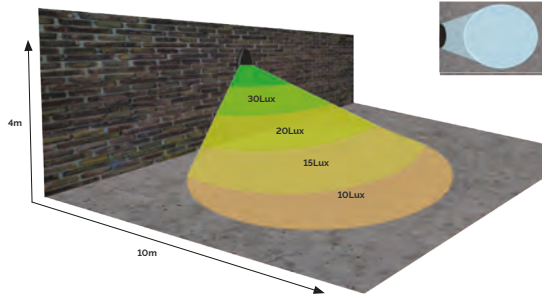

Wide Beam Angle

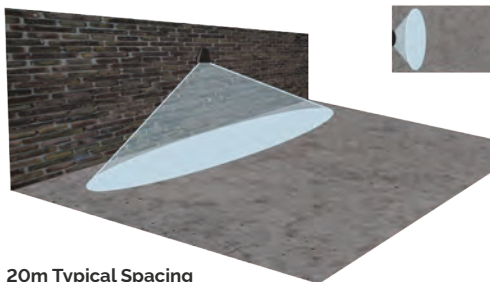

20m Typical Spacing
Based on a 5m mounting height.

T-Beam Angle

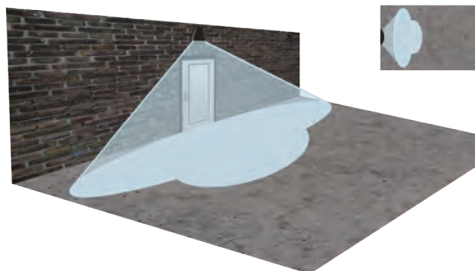

Code Builder	
SEL/ SEG/	Stealth Elite Clear Diffuser Stealth Elite Glass Diffuser
Colour Finish	
B X	Black Titanium
Correlated Colour Temperature	
3 4	3000K 4000K
LED Package	
LED1500 LED2000 LED3000 LED3500 LED4000 LED5000	13W 16W 22W 27W 30W 43W
Beam Angle	
-SO -M1 -T	Flood Beam Angle Wide Beam Angle T-Beam Angle
Options	
M C P	3 Hour Maintained Emergency Photocell PIR

Code Example

SEL/B4LED3000-SO

Stealth Elite Clear Diffuser, Black, 4000K, 22W, 2807 lm, Flood Beam Angle



LITEHOUSE BOLLARD

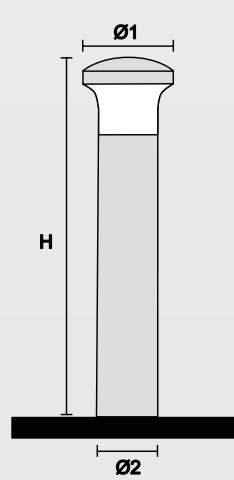

Size	
Height	1015mm
Diameter 1	260mm
Diameter 2	153mm

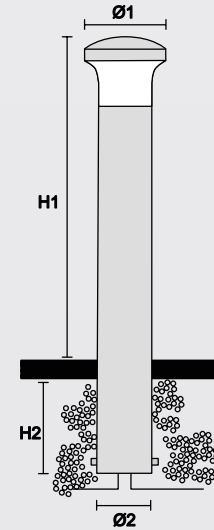

Size	
Height 1	1015mm
Height 2	400mm
Diameter 1	260mm
Diameter 2	153mm



Access Door
(Galvanized steel version only)
LHR/_G

The ASD LiteHouse bollard provides a stylish, robust and efficient unit for illuminating pedestrian areas, pathways & carparks and defining routes and edges within designated areas.

- Root mount & surface mount versions.
- Black and titanium colour finishes available.
- Bollard column available in high impact PVC or powder coated aluminium.
- Maximises downward light & minimises upward light.
- Diffuser available in opal and Fresnel prismatic.
- Adjustable ground trim / kick plate (optional).
- Root mount first fit kit.
- PVC shaft option simplifies earthing requirements + removes touch potential.
- Galvanized steel with door access.

- 60,000 hours to L70.
- IP65 / IK10.
- 5 Year LED guarantee.
- Emergency option available.
- Photocell option available.
- 3000 K available on request.
- Access door option available in galvanized steel version only.
- Fluorescent options available.



Apartment Building,
Solihull

Code Builder	
LHR/ LHS/	Litehouse Root Mounted Litehouse Surface Mounted
Colour Finish	
B X	Black Titanium
Height	
1	1 Metre
Material	
P A G	High Impact PVC Aluminium Column Galvanized steel
Diffuser	
L F	Premium Opal Louvre
Drive Current	
LED35 LED50	350mA 500mA
Options	
M C	3 Hour Maintained Emergency Photocell

Code Example

LHR/B1PFLED50C

Litehouse Bollard, Black, High Impact PVC, Louvre diffuser, LED, 500mA, Photocell.



This luminaire is a high performance bespoke engineered handrail with integral IP65 LED lighting units for the illumination of stairs, walkways & bridges.

The ViperRAIL™ LED system is the ideal solution where stairs and walkways need to be illuminated in a Discreet and uniform method.

Available with either brushed stainless, powder coated or warm-touch finishes. This handrail is suitable for both internal and external use.

The striking design features and the use of LED light, allows it to architecturally enhance the environment where it is installed. At the same time the ViperRAIL™ LED provides the essential safety requirements for pedestrians.

- Project specific LED handrail system.
- Handrail manufactured from 316 stainless steel.
- Super tough IK10 polycarbonate luminaire optics and anodised aluminium heat sink.
- Symmetrical / asymmetric distributions available.
- 48mm diameter handrail.
- In excess of 100,000 hours to L85 B10.
- Class III luminaire SELV compliant.
- Warm to touch coating available if required.
- 4000 K CRI 75 light source as standard other colours available.
- Full range of rail end terminations and supports available.
- Dimming available as an option.
- Can be connected to static inverter / ups to offer emergency operation.
- LED module lengths available: 300, 600, 900 and 1200mm.
- Can be used for compliance with building regulations Part K, BS5395, DDA.
- Single and twin circuit wiring available.
- Available in any paint colour.



Asymmetric

Asymmetric provides illumination to walkways or gives an ambient glow to walls, highlighting the route of travel without the need for lamp posts.

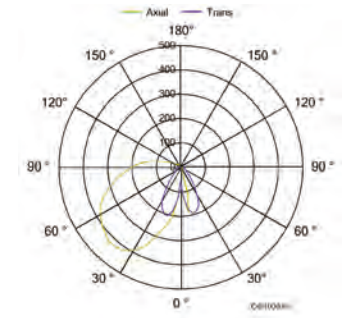
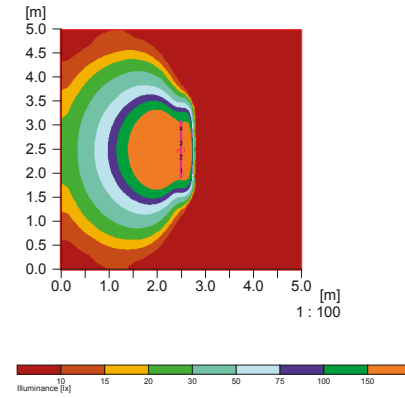

Bi-Asymmetric

Bi-Asymmetric provides even illumination from the rail to either side of it, ideal for divider rails and a modern alternative to lamp posts.

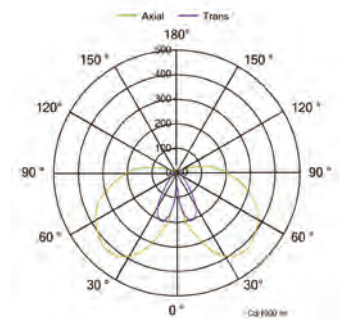
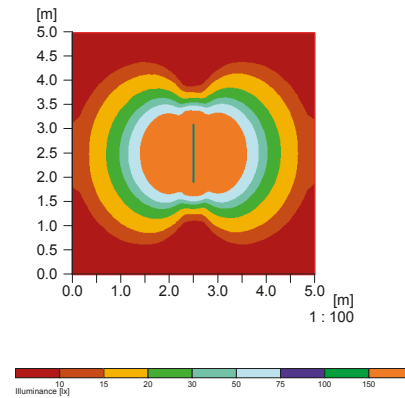

INVINCIBLE LED

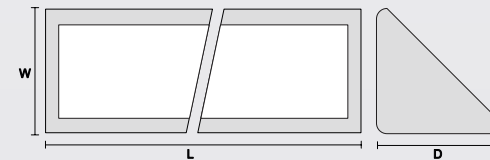

Size

Width	673mm
Height	158mm
Depth	158mm

High efficiency cornice luminaire providing a robust vandal resistant and energy efficient option for high dependency and security applications.

- Cornice mount.
- White colour finish.
- Steel body & vandal resistant 4mm thick prismatic GE lexan polycarbonate diffuser.
- 600mm, 1200mm & 1500mm lengths available.
- IP20 + IP66.
- 150 Joules of impact resistance (IK16).
- 'F' Mark.
- CE.
- BS EN 60598.
- 5 Year LED guarantee.
- Emergency option available.
- Night light option available.
- DSI / DALI Dimmable available.
- Microwave on / off available.
- e-Motion™ Corridor available.
- Fluorescent options available.



Wonderpass
Subway, London

Code Builder	
IV6/ IV12/ IV15/	Invincible LED 673mm Invincible LED 1273mm Invincible LED 1573mm
Colour Finish	
W	White
Diffuser	
K	Prismatic
Correlated Colour Temperature	
3	3000K
4	4000K
LED Quantity	
LED3000	LED 3000
LED6000	LED 6000 (Excluding 673mm body)
LED7500	LED 7500 (Excluding 673mm body)
Options	
M	3 Hour Maintained Emergency
-CFP	e-Motion™ Microwave Master Dim
-CFS	e-Motion™ Microwave Slave Dim
-9	Microwave On/Off
-DDD	DALI / DSI Dim
-DA	Analogue Dim
-DD	Switch Dim
-CLED3	Night Light

Code Example

IV12/WK4LED3000M

Invincible LED 1273mm, White, Prismatic, 4000K, LED 3000, Emergency.

TITAN LED

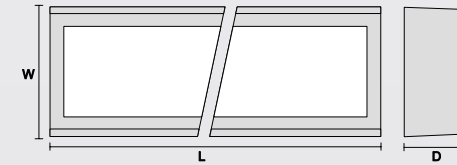

Size

Width	673mm
Height	254mm
Depth	92mm

High efficiency anti-vandal luminaire, suitable for healthcare, secure units, external tunnels and public walkways.

- Surface mounted (Wall or ceiling).
- White colour finish.
- 1.2mm mild steel body & vandal resistant 4mm thick prismatic GE lexan polycarbonate diffuser.
- 600mm, 1200mm & 1500mm lengths available.
- 60,000 hours to L70/B50 (5 x the life of fluorescent lighting).
- IP20 + IP66.
- 150 Joules of impact resistance (IK16).
- 'F' Mark.

- CE.
- BS EN 60598.
- 5 Year LED guarantee.
- Emergency option available.
- Night light option available.
- DSI / DALI Dimmable available.
- Microwave on / off available.
- e-Motion™ Corridor available.
- Fluorescent options available.





Colinton Tunnel,
Edinburgh

Code Builder	
TT6/ TT12/ TT15/	Titan LED 673mm Titan LED 1273mm Titan LED 1573mm
Colour Finish	
W	White
Diffuser	
K	Prismatic
Correlated Colour Temperature	
3	3000K
4	4000K
LED Quantity	
LED3000 LED6000 LED7500	LED 3000 LED 6000 (Excluding 673mm body) LED 7500 (Excluding 673mm body)
Options	
M -CFP -CFS -9 -DDD -DA -DD -CLEDD3	3 Hour Maintained Emergency e-Motion™ Microwave Master Dim e-Motion™ Microwave Slave Dim Microwave On/Off DALI / DSI Dim Analogue Dim Switch Dim Night Light

Code Example

TT12/WK4LED3000-9

Titan LED 1273mm, White, Prismatic, 4000K, LED 3000, Microwave On / Off.



Facility photos from our head office & factory in Rotherham.





Facility photos from our head office & factory in Rotherham.





Facility photos from our head office & factory in Rotherham.





Mangham Road, Barbot Hall Industrial Estate, Rotherham, S61 4RJ, United Kingdom

 asdlighting.com

 asdstreetlighting.com

 +44 (0) 1709 374898

 sales@asdlighting.com