



Power Factor Correction Equipments

Made in Italy



Three-phase capacitors



The COMAR factory, established in 1968, was built with the future in mind. By installing superior equipment the factory has remained technologically advanced even by to-day's standards.

Originally, the production was based on a wide range of "oil-paper" capacitors.

The quality of the product was such that the COMAR brand was soon acknowledged both in Italy and world wide.

A large investment in research and development during this early period made it possible to commence production of the innovative metallized polypropylene film capacitors.

The capacitors became part of the standard range in the 1972 and are still produced by all the main manufactures in the capacitors market. In the following years, the range was enlarged by addition of electrolytic capacitors and capacitors specifically for power electronics.

Power factor correction equipment and power factor regulators were also developed in this period.

Within recent years, because of the diffusion of static power converters, COMAR has examined and resolved the intricate problems of reactive compensation presented by harmonics.

Their study of this subject has been so successful that COMAR is one of the leaders in this very demanding field.

At present, due to the complete automation of all production lines and advanced test equipment it has been possible to increase production and improve the level of quality.

As a mark of Quality IMQ has recognised tests performed at the factory laboratory for product safety and performance.

This is COMAR.

Network analyser



P.F. Correction equipments and filters for harmonics reduction



- ▶ Quality Certificates page 2
- ▶ General information page 4
- ▶ Automatic P.F. correction equipment with blocking reactors AAR/100 and AAR/138 type page 12
- ▶ Modular rack with blocking reactors RC-AAR/100 type page 14
- ▶ Power Factor Regulator BMR type page 15
- ▶ Static automatic P.F. correction equipment AAR/100/ST type page 16
- ▶ Dimensional drawings page 18

Certificate No. IMQ-130/TMP

AUTHORIZATION

WE DECLARE THAT

COMAR CONDENSATORI S.p.A.

IN ITS TESTING LABORATORY OF

**Laboratorio prove
Via del Lavoro 80
Crespellano BO - Italy**

HAS BEEN AUTHORIZED FOR THE APPLICATION OF PROCEDURE

TESTING at MANUFACTURER'S PREMISES (TMP)
AS DESCRIBED IN INTERNATIONAL DOCUMENTS OD-CB2028 / OD-CIG037
IN THE PERFORMING OF TESTS ON

MOTOR CAPACITORS

Standards:

- EN 60252-1:2001 ; IEC 60252-1:2001

SHUNT CAPACITORS OF SELF-HEALING TYPE

Standards:

- EN 60831-1:1996 + A1:2003 ; IEC 60831-1:1996 + A1:2002
- EN 60831-2:1996 + A1:2003 ; IEC 60831-2:1995

CAPACITORS FOR FLUORESCENT AND OTHER DISCHARGE LAMP CIRCUITS

Standards:

- EN 61048:1993 + A1:1996 + A2:1999 ; IEC 61048:1991+ A1:1995 + A2:1999
- EN 61048:2006 ; IEC 61048:2006
- EN 61049:1993 ; IEC 61049:1991

THE TESTS PERFORMED ARE RECOGNIZED BY **IMQ S.p.A.**

AS BASIS TO ISSUE ITS OWN CERTIFICATIONS

IMQ S.p.A.

Approval date: 2008-01-30

Expiry date: 2011-01-29

THE VALIDITY OF THIS CERTIFICATE IS SUBJECT TO THE CONTINUOUS RESPECT OF RELEVANT IMQ RULES

Mod. 934TMP/1



IMQ S.p.A. I-20139 Milano - Via Quintilano 45 - tel. 02507311ra | - fax 0250991500 - info@imq.it - www.imq.it
Rea Mi 1595884 - Registro Imprese Mi 12898410159 - C.F./P.I.: 12898410159 - Capitale sociale 4.000.000 euro.



DEFINITION OF POWER FACTOR

Inductive electrical loads demand more power than they convert to useful energy. Induction motors, for example, convert at most 80-90% of the delivered power into useful work or electrical losses. The remaining power is used to establish an electromagnetic field in the motor. The field is alternately expanding and collapsing, thus the power drawn into the field in one instant is returned to the electric supply system in the next instant. The average power drawn by the field is zero.

The electrical current drawn by induction loads consists of two elements. The first of these is in-phase with the supply voltage. The second, and greater, element is out-of-phase with the supply voltage and lags the supply voltage by 90 electrically.

The lagging current is primarily consumed to by the field windings of an induction motor. The total current drawn by an induction load is the vectoral sum of the in and out-of-phase elements.

The out-of-phase current has the effect of increasing the current demand of a motor. This, in turn, increases heating in cables and transformers supplying the motor. The additional current also increases voltage drop across these components.

It is necessary to oversize transformers, cables and other elements in the supply circuit to such induction loads. Such oversizing results in an increase in the cost of the installation.

Demand power, calculated by multiplying the total (vectorially summed) current drawn by an induction load and the rms value of the supply voltage, is termed "apparent power". Apparent power is measured in kilo-volt amperes (kVA). The supply kVA is a measure of the capacity for which a system must be built.

Power consumed, calculated by multiplying the in-phase element of the current drawn by the rms value of the supply voltage, is termed "active power". Active power, is measured in kilowatts (kW). Power factor is the ratio of active power to apparent power:

$$\text{Cos } \varphi = \frac{\text{kW}}{\text{kVA}}$$

The highest possible power factor is 1.0, which means that 100% of the power delivered to the load is active power converted into useful energy.

Anything less than 1.0 indicates that the supply system must be built larger in order to serve the load.

Traditionally, concern for power factor has been almost exclusively linked with use of induction motors.

Now, facility engineers are also confronted with other non-linear loads. Power electronic equipment, for example variable speed motor drives, uninterruptible power supplies, and induction furnaces, are the common types of non-linear loads. Arcing loads, for example arc-furnaces and arc-welders are also non linear.

Like inductive loads, non-linear loads degrade power factor by "borrowing" and returning power to the power supply system. The power system delivers current to a non linear load at the fundamental frequency (for example 50 Hz), and the load returns some of the current at higher, harmonic, frequencies (see figure 1). The current wave-form contains multiple frequencies and, therefore, is not sinusoidal.

Where harmonic distortion of the supply waveform is present it is important to note that the harmonic current elements will contribute to the power factor.

As such the traditional methods for analyzing power factor are not appropriate when dealing with non-linear loads.

The definition of power factor as the ratio of active power to apparent power, on the other hand, is always correct, providing that the harmonic contribution to kVA and kW is accounted for.

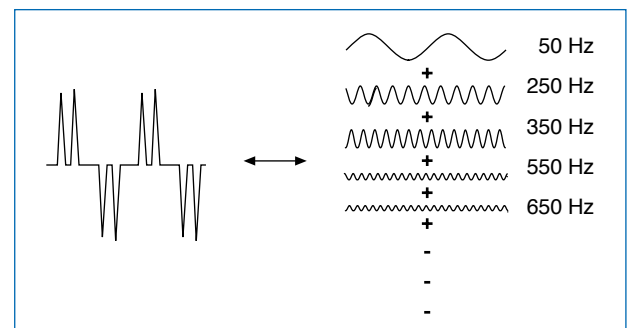

Figure 1:
Distorted current can be regarded as a sum of sinusoidal currents of various frequencies.

THE POWER TRIANGLE

The power triangle is commonly used to describe power factor for motors and others linear loads.

Although it is not as applicable to non-linear loads such as adjustable-speed drives, it is still a useful concept to understand. The power triangle can be illustrated using the R-X branch as shown below. If the branch voltage is perfectly sinusoidal, the current must also be sinusoidal, and will lag the voltage by some angle, φ , called the “displacement angle”, or the power factor angle.

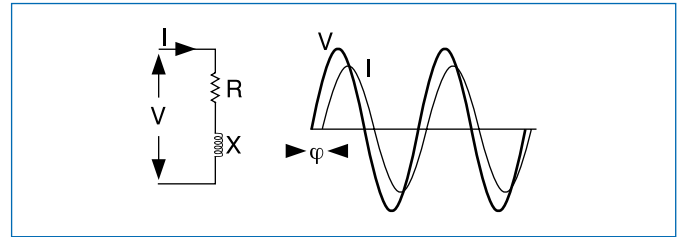

Figure 2:
Displacement angle

The formulas for apparent power S, and active power P, yield the well known definition of power factor:

$$\begin{aligned} P &= R \cdot I^2 \\ S &= V \cdot I^2 \end{aligned} \Rightarrow \frac{P}{S} = \cos\varphi = \text{DPF}$$

The term displacement power factor (DPF) is used to emphasize that the power factor has been calculated using the displacement angle, as opposed to true power factor (TPF), which is the ratio of P to S. This distinction is not normally made because when no harmonic sources are present $\text{DPF} = \text{TPF}$. It is the DPF that most utilities currently measure, but there is a movement among some to measure TPF, which would include the effects of harmonic distortion. There are now electronic meters available which are capable of recording TPF accurately.

The formula $P = S \cdot \cos\varphi$ indicates that a right triangle relationship exists between the vectors for P and S as shown in Figure 3.

The third side of the triangle, designated as Q, is called the “reactive power” and is measured in kVAr (kilovolt amperes reactive).

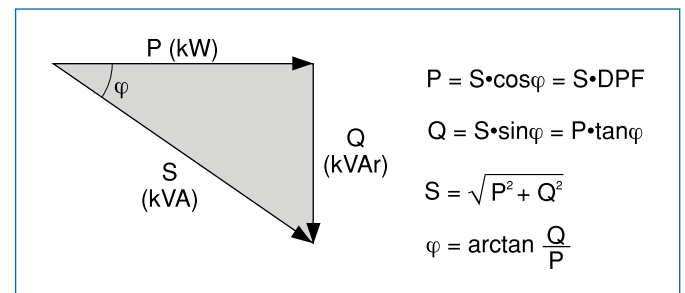

Figure 3:
Power triangle

Q is actually a convenient mathematical contrivance, but is very useful because, if there is no distortion, it is conserved, just as active power is conserved. That is, the reactive power (vars) appears to flow around the system just like the active power (watts). In this concept, motor absorb vars while capacitors produce vars.

WHY SHOULD POWER FACTOR BE IMPROVED?

Raising system power factor provides the following benefits:

- lower utility charges
- increased system capacity
- less voltage drop
- reduced losses

Reduced Electric Utility Charges

Thermal capacity considerations, discussed below, force the electric utility to overbuild its distribution system in order to serve a facility with low power factor.

The utility may or may not charge the customer for the increased expense of larger system components. If it does, then adding capacitors is usually justifiable.

Increasing System Capacity

The thermal capacity of generators, transformer, and cables limit the kVA that can be supplied from the system. Reducing the net kvar demand from existing loads allows additional load to be added to the system.

Improving Voltage

High load kvar demand increases the voltage drops across transformers, cables, and other system components, resulting in decreased equipment utilization voltage.

In a weak system, capacity can be limited by excessive voltage drop, rather than by component thermal ratings.

Reducing Circuit Losses

Since circuit current is reduced in direct proportion to the increase in power factor, the I²R loss, or resistive loss, in the circuit is inversely proportional to the square of the power factor. By itself, loss reduction doesn't justify the cost of installing capacitors, but the added benefit can be substantial.

METHODS OF REACTIVE COMPENSATION

Capacitors

By nature of its electrostatic field, the capacitor stores energy when ever the voltage applied across the capacitors is moving away from zero; it gives up energy after the voltage as crested. This sequence is opposite to that of the magnetic field, so the capacitor can be used to supply magnetizing current that would otherwise be drawn from the utility source.

Capacitors are generally the most economical source of reactive compensation. Other advantages include:

- low losses (less than 1/4 Watt / kvar)
- essentially no maintenance
- light, compact units which can be combined as needed, make capacitors relatively easy to install and modify as reactive compensation needs change.

Static Var System

Loads such as arc furnaces and welders exhibit a rapidly changing current demand which may result in an unacceptable fluctuation of bus voltage, called flicker.

One way to eliminate the flicker problem is to use a controller that can match the load's instantaneous reactive current demand.

Only static var controllers employing semiconductor switches provide the speed required to accomplish this.

COMPENSATION SYSTEM

Individual correction

This type of compensation is reasonable for consumer are turned with high capacities, constant load and long operating times.

- The capacitor is installed close to the operating equipment. The lower current flows already in the line from the bus bar to the consumer.
- The capacitor and the consumer are turned on and off together; an additional switch is not required.

When selecting the type of capacitors note that in the case of induction motors, the reactive power supplied by the capacitor must not exceed approx. 90% of the motor reactive power in idle operation. Otherwise, disconnection might cause self-excitation by the resonance frequency, since the motor and the capacitor form a resonant circuit. This effect may lead to high over voltages at the terminals and affect the insulation of the operating equipment.

Group Correction

A group of consumers, e.g. motors of fluorescent lamps, operated by one common switch, can be compensated with one single capacitor.

Centralized Correction

The solution for correcting the power factor for a great number of small consumers with varying power consumption is a centralized compensation principle using switched capacitor modules and a controller. The low losses of the capacitors allows them to be integrated directly in the switchboards or distributors.

A programmable controller is used to monitor the power factor and to switch the capacitors according to the reactive-power flow.

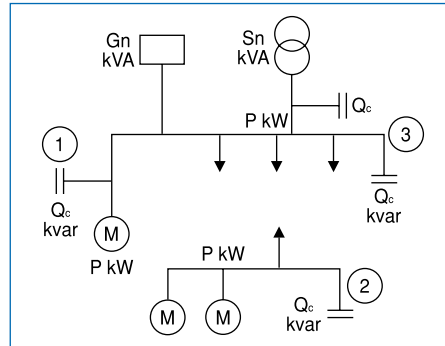

Figure 4:
Installation examples

CAPACITORS SIZING

The loads connected in a 3-phase system present an inductive characteristic which causes the absorption of active and reactive power. This reactive power is an undesired load for the supply line and it leads to higher expenses on the energy bill. Reactive power can be balanced by the presence of power factor correction capacitors.

The power triangle calculations of Figure 3 simplify to: (where M is calculated as show in the following table)

$$\text{kvar}_{\text{Cap}} = \text{kW}_{\text{Load}} \cdot (\tan\phi_1 - \tan\phi_2) = \text{kW}_{\text{Load}} \cdot M$$

Example: $P = 1000 \text{ kW} - \cos\phi_1 = 0,65$

From table: $M = 0,88$ for $\cos\phi_2 = 0,96$

At the end: $Q = 1000 \times 0,88 = 880 \text{ kvar}$

Table for the determination of M factor

	$\tan\phi_2$	0,62	0,59	0,57	0,54	0,51	0,48	0,46	0,43	0,40	0,36	0,33	0,29	0,25	0,20	0,14	0,00
	$\cos\phi_2$	0,85	0,86	0,87	0,88	0,89	0,90	0,91	0,92	0,93	0,94	0,95	0,96	0,97	0,98	0,99	1,00
$\tan\phi_1$	$\cos\phi_1$																
4,90	0,20	4,28	4,31	4,33	4,36	4,39	4,41	4,44	4,47	4,50	4,54	4,57	4,61	4,65	4,70	4,76	4,90
3,87	0,25	3,25	3,28	3,31	3,33	3,36	3,39	3,42	3,45	3,48	3,51	3,54	3,58	3,62	3,67	3,73	3,87
3,18	0,30	2,56	2,59	2,61	2,64	2,67	2,70	2,72	2,75	2,78	2,82	2,85	2,89	2,93	2,98	3,04	3,18
2,68	0,35	2,06	2,08	2,11	2,14	2,16	2,19	2,22	2,25	2,28	2,31	2,35	2,38	2,43	2,47	2,53	2,68
2,29	0,40	1,67	1,70	1,72	1,75	1,78	1,81	1,84	1,87	1,90	1,93	1,96	2,00	2,04	2,09	2,15	2,29
1,98	0,45	1,36	1,39	1,42	1,44	1,47	1,50	1,53	1,56	1,59	1,62	1,66	1,69	1,73	1,78	1,84	1,98
1,73	0,50	1,11	1,14	1,17	1,19	1,22	1,25	1,28	1,31	1,34	1,37	1,40	1,44	1,48	1,53	1,59	1,73
1,52	0,55	0,90	0,93	0,95	0,98	1,01	1,03	1,06	1,09	1,12	1,16	1,19	1,23	1,27	1,32	1,38	1,52
1,33	0,60	0,71	0,74	0,77	0,79	0,82	0,85	0,88	0,91	0,94	0,97	1,00	1,04	1,08	1,13	1,19	1,33
1,23	0,63	0,613	0,639	0,666	0,693	0,720	0,748	0,777	0,807	0,837	0,870	0,904	0,941	0,982	1,030	1,090	1,233
1,17	0,65	0,55	0,58	0,60	0,63	0,66	0,68	0,71	0,74	0,77	0,81	0,84	0,88	0,92	0,97	1,03	1,17
0,14	0,66	0,519	0,545	0,572	0,599	0,626	0,654	0,683	0,712	0,743	0,775	0,810	0,847	0,888	0,935	0,996	1,138
1,11	0,67	0,488	0,515	0,541	0,568	0,596	0,624	0,652	0,682	0,713	0,745	0,779	0,816	0,857	0,905	0,966	1,108
1,08	0,68	0,459	0,485	0,512	0,539	0,566	0,594	0,623	0,652	0,683	0,715	0,750	0,787	0,828	0,875	0,936	1,078
1,05	0,69	0,429	0,456	0,482	0,509	0,537	0,565	0,593	0,623	0,654	0,686	0,720	0,757	0,798	0,846	0,907	1,049
1,02	0,70	0,40	0,43	0,45	0,48	0,51	0,54	0,56	0,59	0,62	0,66	0,69	0,73	0,77	0,82	0,88	1,02
0,99	0,71	0,37	0,40	0,43	0,45	0,48	0,51	0,54	0,57	0,60	0,63	0,66	0,70	0,74	0,79	0,85	0,99
0,96	0,72	0,34	0,37	0,40	0,42	0,45	0,48	0,51	0,54	0,57	0,60	0,64	0,67	0,71	0,76	0,82	0,96
0,94	0,73	0,32	0,34	0,37	0,40	0,42	0,45	0,48	0,51	0,54	0,57	0,61	0,64	0,69	0,73	0,79	0,94
0,91	0,74	0,29	0,32	0,34	0,37	0,40	0,42	0,45	0,48	0,51	0,55	0,58	0,62	0,66	0,71	0,77	0,91
0,88	0,75	0,26	0,29	0,32	0,34	0,37	0,40	0,43	0,46	0,49	0,52	0,55	0,59	0,63	0,68	0,74	0,88
0,86	0,76	0,24	0,26	0,29	0,32	0,34	0,37	0,40	0,43	0,46	0,49	0,53	0,56	0,60	0,65	0,71	0,86
0,83	0,77	0,21	0,24	0,26	0,29	0,32	0,34	0,37	0,40	0,43	0,47	0,50	0,54	0,58	0,63	0,69	0,83
0,80	0,78	0,18	0,21	0,24	0,26	0,29	0,32	0,35	0,38	0,41	0,44	0,47	0,51	0,55	0,60	0,66	0,80
0,78	0,79	0,16	0,18	0,21	0,24	0,26	0,29	0,32	0,35	0,38	0,41	0,45	0,48	0,53	0,57	0,63	0,78
0,75	0,80	0,13	0,16	0,18	0,21	0,24	0,27	0,29	0,32	0,35	0,39	0,42	0,46	0,50	0,55	0,61	0,75
0,72	0,81	0,10	0,13	0,16	0,18	0,21	0,24	0,27	0,30	0,33	0,36	0,40	0,43	0,47	0,52	0,58	0,72
0,70	0,82	0,08	0,10	0,13	0,16	0,19	0,21	0,24	0,27	0,30	0,34	0,37	0,41	0,45	0,49	0,56	0,70
0,67	0,83	0,05	0,08	0,11	0,13	0,16	0,19	0,22	0,25	0,28	0,31	0,34	0,38	0,42	0,47	0,53	0,67
0,65	0,84	0,03	0,05	0,08	0,11	0,13	0,16	0,19	0,22	0,25	0,28	0,32	0,35	0,40	0,44	0,50	0,65
0,62	0,85		0,03	0,05	0,08	0,11	0,14	0,16	0,19	0,22	0,26	0,29	0,33	0,37	0,42	0,48	0,62
0,59	0,86			0,03	0,05	0,08	0,11	0,14	0,17	0,20	0,23	0,26	0,30	0,34	0,39	0,45	0,59
0,57	0,87				0,03	0,05	0,08	0,11	0,14	0,17	0,20	0,24	0,28	0,32	0,36	0,42	0,57
0,54	0,88					0,03	0,06	0,08	0,11	0,14	0,18	0,21	0,25	0,29	0,34	0,40	0,54
0,51	0,89						0,03	0,06	0,09	0,12	0,15	0,18	0,22	0,26	0,31	0,37	0,51
0,48	0,90							0,03	0,06	0,09	0,12	0,16	0,19	0,23	0,28	0,34	0,48
0,46	0,91								0,03	0,06	0,09	0,13	0,16	0,20	0,25	0,31	0,46
0,43	0,92									0,03	0,06	0,10	0,13	0,18	0,22	0,28	0,43
0,40	0,93										0,03	0,07	0,10	0,14	0,19	0,25	0,40
0,36	0,94											0,03	0,07	0,11	0,16	0,22	0,36

$\cos\phi_1$ = original power factor before correction - $\cos\phi_2$ = new power factor

HARMONICS CONSIDERATION

What are harmonic?

Non-linear loads draw current which is distorted resulting in the presence of multiple frequencies.

A non-linear load can be visualized as a current source, drawing current from the system at the fundamental frequency, and injecting current back into the system at higher frequencies.

The current waveform, though distorted, is usually identical from one cycle to the next. This means that all frequencies in the waveform are harmonics (integer multiples) of the fundamental. For example, the harmonics contained in the waveform of Figure 1 are 1, 5, 7, 11 ... Why only these harmonics? The current waveforms with identically shaped positive and negative half cycles do not have any even harmonics (2, 4, ...).

Triplen harmonics (odd multiples of 3, 9, 15, ...) are usually negligible for the type of three-phase non-linear loads that we generally encounter for industrial power factor correction. However, they can be quite significant for single-phase loads. Figure 5 shows the reason why. If the harmonic sources in each phase are balanced, any third harmonic components in the phase current must be in phase.

Therefore, they add directly into the neutral, if it exists. Summing currents at the neutral node, N, shows that if the circuit has a neutral wire and is serving single-phase loads, the third harmonic in the neutral current is three times the third harmonic in the phase current.

On the other hand, if there is no neutral wire, as in the case for the larger 3-phase non linear loads industrial plants, there will generally be no third harmonic current in the phase wires because there is no place for it to flow.

Therefore, we commonly ignore these components for design of power factor capacitor installations unless we have special reasons to believe they exist.

The most common location for triplen harmonic problems in an industrial plant is on 120V / 208V circuits where it is not common to place capacitors for power factor correction.

They also appear commonly on utility 4-wire wye distribution feeders because there are several 3-phase loads.

Why the concern for harmonics?

Distorted currents and the distorted voltages they create as they flow through system impedances, can reduce equipment operating reliability and service life. Potential problems include the following.

Failure of power factor correction capacitors

The presence of power factor correction capacitors in the building greatly increases the potential for harmonic problems.

A capacitor can cause the system to resonate near harmonic frequency, producing high voltage and/or current distortion that can destroy the capacitor or cause nuisance capacitor fuse/breaker operation.

Resonance Frequency is by:

$$f_r = f_0 (P_{cc} / Q_c)^{1/2}$$

Where:

f_r = resonance frequency

f₀ = fundamental frequency (50 Hz)

P_{cc} = Short Circuit Power at Capacitor installation Point

Q_c = Reactive Power

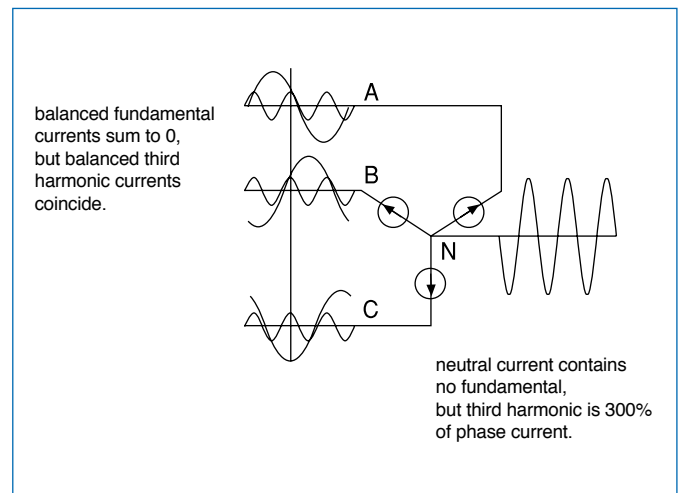

Figure 5:
Flow of triple harmonic currents

By reasonable approx. it is possible to consider

$$P_{cc} = (S / V_{cc}\%) 100$$

Where:

S = Transformer Power

V_{cc}% = Transformer Short Circuit Voltage

Equipment misoperation

Circuit breakers, adjustable speed drives (ASDs), programmable logic controllers, and other equipment employ control circuits that may not operate correctly in a distorted environment.

Distortion of the equipment supply voltage may cause inaccurate measurement of control input signals.

It can produce multiple zero crossing per cycle of the input signal waveform, causing crossing detector to malfunction.

Typical problems include clocks running fast hunting and oscillation in motor speed control system, and circuit breaker failure to trip or nuisance trips.

Voltage distortion can also reduce the ability of electronic equipment to withstand momentary voltage sags and interruptions.

Overheating of transformer

Winding eddy current losses and other stray losses vary roughly with the square of the frequency of the load current.

Therefore, harmonic load currents significantly increase transformer heating.

This problem is most severe in drive-type transformers.

Overloading of neutral conductor

in three-phase 4-wire circuits serving single-phase electronic power supply loads. As with transformers, harmonic current increase conductor heating.

However, the neutral conductor is a special concern due to the phenomenon illustrated in Figure 5. Triplen harmonic currents from each phase add in the neutral.

Though balancing loads among the phases will eliminate fundamental current in the neutral, this is not true for the triplens. Neutral current can be approximately 70% higher than phase conductor current for circuits serving balanced computer loads.

MEASURE OF HARMONIC DISTORTION

There are several measures used for indicating the harmonic content of a waveform with a single number. One of the most common is Total Harmonic Distortion (THD), which can be calculated for voltage or current:

$$THD = \frac{\sqrt{\sum_{h=2}^{\infty} (M_h)^2}}{M_1}$$

where M_h is the rms magnitude of harmonic component h and M_1 is the magnitude of the fundamental value.

THD is related to the rms, or root mean square, value of the waveform as follows:

$$rms = \sqrt{\sum_{h=2}^{\infty} (M_h)^2} = M_1 \cdot \sqrt{1 + THD^2}$$

Capacitor sizing to control resonance

In many cases, harmonic problem can be eliminated by selecting capacitor size to avoid problem resonance.

For an automatically switched bank, step sizes must be selected to skip over resonance, and the controllers programmed accordingly.

Unfortunately, this technique will not always work.

First, the resonant peaks may be so high and broad that any capacitor size within the desired range of compensation is unacceptable. Second, if capacitors are automatically controlled or switched with motors, high diversity in plant load may make it impossible to avoid all resonant configurations.

Fundamentals of Power Factor Correction - Detuned filtering (PFC - DF)

PFC detuned filtering is a technique to correct the power factor avoiding the risk of resonance condition performed by shifting the resonance frequency to lower values where no harmonic currents are present.

This is achieved by modifying the basic LC circuit formed by the transformer and the capacitor bank, introducing a filter reactor in series with the capacitors, making this way a more complex resonant circuit but with the desired feature of having a resonance frequency below the first existing harmonic. This way it's not possible to have a real resonance condition.

Components for PFC detuned filters must be carefully selected according to the desired PFC purpose, to the harmonics present in the system, to some features of the system like short circuit power and impedances, to the desired filtering effect and to the characteristics of the resonant circuit configured.

For example, the voltage across the capacitors will be higher than the nominal grid voltage when they have a reactor connected in series.

The reactors must be selected in line with the inductance value to obtain the desired tuning frequency and current capability high enough for the harmonic current absorption that can be expected. The tuning frequency is usually indirectly referred to as the detuning factor p and expressed as a percentage.

PFC detuned filtering is an engineering speciality that takes experienced know-how to implement in a satisfying and safe way.

$$p = 100\% \left(\frac{x_L}{x_C} \right)$$

Where

x_L = Capacitor bank Inductive impedance

x_C = Capacitor bank Capacitive impedance

$$f_r = f_0 \sqrt{\frac{100\%}{p}}$$

Where

f_r = Detuning frequency

f_0 = Fundamental frequency

The most useful Values are:

$p = 7\%$ - $f_r = 189$ Hz

$p = 14\%$ - $f_r = 134$ Hz

Harmonic filters

The most common type of filter is the band pass ("notch") filter illustrated in Figure 6. The notch refers to the dip in the characteristic at the tuned frequency.

Notch filters provide reactive compensation like a capacitor bank, but the inductors introduce a series resonance which diverts harmonic current into the filter.

Part (c) of the figure shown that the filter does not eliminate parallel resonance - it merely shifts the resonance to some frequency below the notch frequency.

In order to prevent a second resonance problem, filters must be added starting with the lowest problem harmonic. For example, a fifth harmonic filter must be in service before a seventh harmonic filter can be energized.

Notch filters are generally tuned below the harmonic to be suppressed.

Slightly detuning the filter in this way causes the impedance of the filter at the target harmonic to be not quite zero.

This actually reduces capacitor and reactor current duty.

The tuning is always below the target harmonic in order to insure that parallel resonance is well below harmonic.

(Tolerance in the capacitor and reactor ratings may result in the notch and peak frequencies being higher than calculated.)

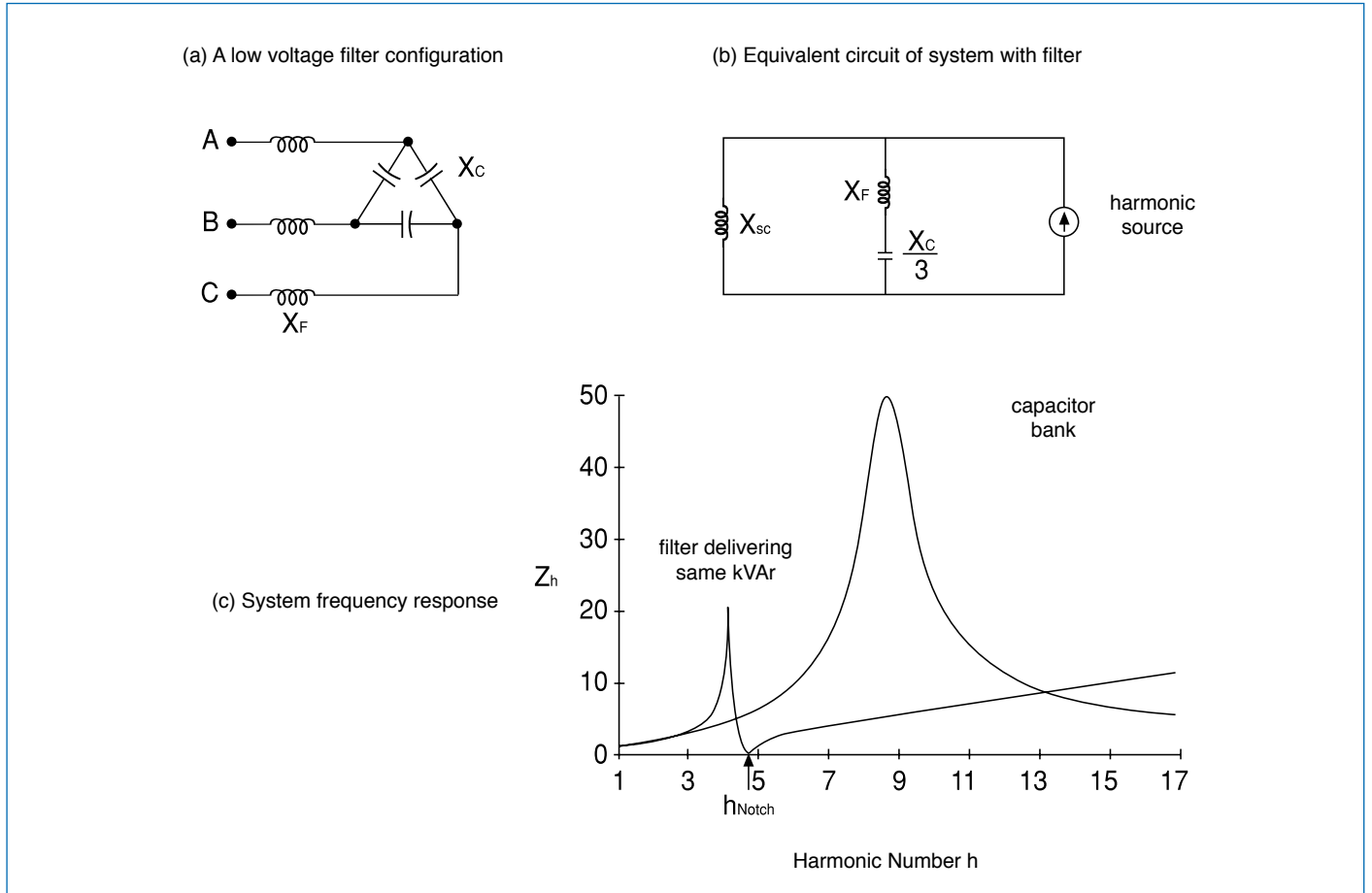

Figure 6:
Effect of notch filter on system response

Modular filter

Designing a filter for individual load, without regard for the system that is the applied on, is asking for trouble. Over load is the most common problem, since the filter will attract harmonic currents from all non-linear loads or the system. Using equipment with modular filters can create problems if capacitors are added to the system.

Other forms of mitigation

Active Filter has been used in low power applications for some time. Units capable of delivering the high levels of harmonic compensation for industrial applications are becoming available.



Automatic P.F. equipments reactor-protected capacitors are used in power supply network with **HIGH HARMONIC DISTORTION** of current (THDI). If the series reactors is selected in such a way a minimum part of the harmonics is charginig the resonance circuit: it is called a “**detuned filter circuit**”.

Complies with 73/23 CEE (93/68 CEE) standards.

MAIN FEATURES

Rated voltage	415Vac for 50Hz (others on request up to 660Vac)
Rated frequency	50Hz (60Hz on request)
Insulation voltage	690V
Voltage of auxiliary circuits	240Vac (110Vac on request) Auxiliary circuits are fed by a suitable transformer
Max. temperature range	ambient +52°C
Cubicle	in robust sheet steel, RAL7032 painted (other on request)
Protection degree	IP 31 (IP 40 and IP 54 on request); indoor IP00 (IP20 on request)
Ventilation	forced
Supply	by means of isolating switch with door interlocking device (MCCB on request). Cable entry from the top for G4RM types, from the bottom for G6E and G8E type
Bus bars withstand current capacity	on request up to 50 KArms/1 sec.
Three-pole contactors	for high reliability each bank of capacitors is controlled by its own three-pole contactor. To limit the switching on inrush current each contactor is provided with pre-charge resistors. Rated voltage of auxiliary circuits 240Vac 50Hz (other upon request)
Fuses	every bank is protected by a set of three HRC fuses (NH00 type - curve gG) with high breaking capacity (100kA)
Capacitors	self-healing polypropylene metallized single-phase (MKP), equipped with overpressure safety device and discharge resistor All are compliant with international standard and PCB free Internal connection: delta rated voltage: 550Vac capacitance tolerance: -5% / +10% total losses of the capacitors: $\leq 0,4$ W/kvar temperature category: -25 / D
Blocking reactors	iron core type with copper winding tuning frequency: 189Hz (p=7%); [138Hz (p=14%) on request] max dissip. losses: 180W for 25kvar banks; 265W for 50kvar banks; 270W for 75kvar banks linearity: $1,9 \div 2$ In max harmonic distortion of voltage allowed on the networks is THDV=3% (higher value on request)
Regulator	type of measurement: VARMETRIC amperometric signal: C.T..../5 Amps voltmetric signal: from inside the cubicle switching on / off times: 25"-30" (7" on request) serial output RS485
Reference Standards	capacitors: CEI EN 60831-1/2, IEC 831-1/2, UL810 equipment: CEI EN 60439-1, IEC 61439-1
Type of service	continuous for indoor operation

Automatic P.F. correction equipment with blocking reactors



GE AAR/100 Type - 415V - 50Hz

THDI_{max} on the network = 100%

Fr = 189Hz; p = 7%

Type	Qn (kvar)	Power of banks (kvar)	N. of steps (n. x kvar)	Current	Switch (A)	Controller (type)	Dimensions b x p x h (mm)	Weight (kg)
G4RM AAR/100	100	25 25 25 25	4 x 25	139	200	BMR6	550x430x1210	145
G6E AAR/100	125	25 50 50	5 x 25	174	250	BMR8	600x600x1600	200
G6E AAR/100	150	25 50 75	6 x 25	209	315			220
G6E AAR/100	175	25 50 50 50	7 x 25	243	400			250
G6E AAR/100	200	25 50 50 75	8 x 25	278	400			270
G6E AAR/100	225	25 50 75 75	9 x 25	313	500			300
G6E AAR/100	250	25 25 50 75 75	10 x 25	348	500			320
G6E AAR/100	275	25 50 50 75 75	11 x 25	383	630			340
G6E AAR/100	300	25 50 75 75 75	12 x 25	417	630			360
G8E AAR/100	350	50 75 75 75 75	7 x 50	487	800	BMR8	600x600x2000	390
G8E AAR/100	375	25 50 75 75 75 75	15 x 25	522	800			410
G8E AAR/100	400	50 50 75 75 75 75	8 x 50	556	800	BMR8	1200x600x2000	550
G8E AAR/100	450	25 50 75 75 75 75 75	18 x 25	626	1000			600
G8E AAR/100	500	50 75 75 75 75 75 75	10 x 50	696	1000			650
G8E AAR/100	550	50 50 75 75 75 75 75 75	11 x 50	765	1250			700
G8E AAR/100	600	75 75 75 75 75 75 75 75	8 x 75	835	1250			750
G8E AAR/100	650	50 75 75 75 75 75 75 75 150	13 x 50	904	800 + 630			800
G8E AAR/100	750	75 75 75 75 75 75 150 150	10 x 75	1043	800 + 800			850
G8E AAR/100	825	75 75 75 75 75 150 150 150	11 x 75	1148	630 + 1000	BMR8	1800x600x2000	1000
G8E AAR/100	900	75 75 75 75 150 150 150 150	12 x 75	1252	630 + 1250			1050
G8E AAR/100	975	75 75 75 150 150 150 150 150	13 x 75	1356	800 + 1250			1100
G8E AAR/100	1050	75 75 150 150 150 150 150 150	14 x 75	1461	800 + 1600			1150

GE AAR/138 Type - 415V - 50Hz

THDI_{max} on the network = 100%

Fr = 138Hz; p = 14%

Type	Qn (kvar)	Power of banks (kvar)	N. of steps (n. x kvar)	Current	Switch (A)	Controller (type)	Dimensions b x p x h (mm)	Weight (kg)
G4RM AAR/138	100	25 25 25 25	4 x 25	139	200	BMR6	550x430x1210	145
G6E AAR/138	125	25 50 50	5 x 25	174	250	BMR8	600x600x1600	200
G6E AAR/138	150	25 50 75	6 x 25	209	315			220
G6E AAR/138	175	25 50 50 50	7 x 25	243	400			250
G6E AAR/138	200	25 50 50 75	8 x 25	278	400			270
G6E AAR/138	225	25 50 75 75	9 x 25	313	500			300
G6E AAR/138	250	25 25 50 75 75	10 x 25	348	500			320
G6E AAR/138	275	25 50 50 75 75	11 x 25	383	630			340
G6E AAR/138	300	25 50 75 75 75	12 x 25	417	630			360
G8E AAR/138	350	50 75 75 75 75	7 x 50	487	800	BMR8	600x600x2000	390
G8E AAR/138	375	25 50 75 75 75 75	15 x 25	522	800			410
G8E AAR/138	400	50 50 75 75 75 75	8 x 50	556	800	BMR8	1200x600x2000	550
G8E AAR/138	450	25 50 75 75 75 75 75	18 x 25	626	1000			600
G8E AAR/138	500	50 75 75 75 75 75 75	10 x 50	696	1000			650
G8E AAR/138	550	50 50 75 75 75 75 75 75	11 x 50	765	1250			700
G8E AAR/138	600	75 75 75 75 75 75 75 75	8 x 75	835	1250			750
G8E AAR/138	650	50 75 75 75 75 75 75 150	13 x 50	904	800 + 630			800
G8E AAR/138	750	75 75 75 75 75 150 150	10 x 75	1043	800 + 800			850
G8E AAR/138	825	75 75 75 75 150 150 150	11 x 75	1148	630 + 1000	BMR8	1800x600x2000	1000
G8E AAR/138	900	75 75 75 75 150 150 150 150	12 x 75	1252	630 + 1250			1050
G8E AAR/138	975	75 75 75 150 150 150 150 150	13 x 75	1356	800 + 1250			1100
G8E AAR/138	1050	75 75 150 150 150 150 150 150	14 x 75	1461	800 + 1600			1150

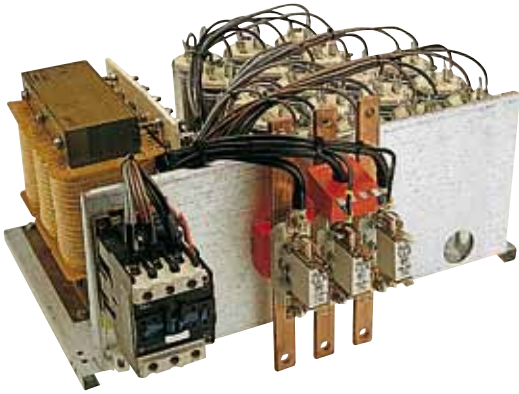

These modular racks have conveniently designed for their installation inside boards and are equipped with bars for series connection. The bars are dimensioned for a maximum power of 300kvar 415vac 50Hz.

The racks must be fitted on guides, which are spaced at 260mm. and are made of galvanized sheet-steel.

They comprise the capacitors, the blocking reactor, the contactor, the fuses, and the terminal board for the connection of the auxiliary 240Vac circuits. Adequate ventilation should be provided.

Modular rack with blocking reactors

RC-AAR/100...SB Type - 415V - 50Hz

THDI_{max} on the network = 100% (on the capacitors = 85%)

Type	Qn (kvar)	Un V	In A	Power of banks (kvar)	N. of steps (n. x kvar)	Dimensions b x p x h (mm)	Weight (kg)
RC-M-AAR/100 (G6/8E)	12,5	415	17	12,5	1 x 12,5	532 x 480 x 300	25
RC-M-AAR/100 (G6/8E)	25	415	35	25	1 x 25		31
RC-M-AAR/100 (G6/8E)	50	415	70	50	1 x 50		49
RC-M-AAR/100 (G6/8E)	75	415	104	75	1 x 75		67
RC-M-AAR/100 (G6/8E)	75	415	104	25 + 50	25 -50 -75		70

Warning: do not assemble more than 300kvar 415Vac 50Hz (max. current 430A).

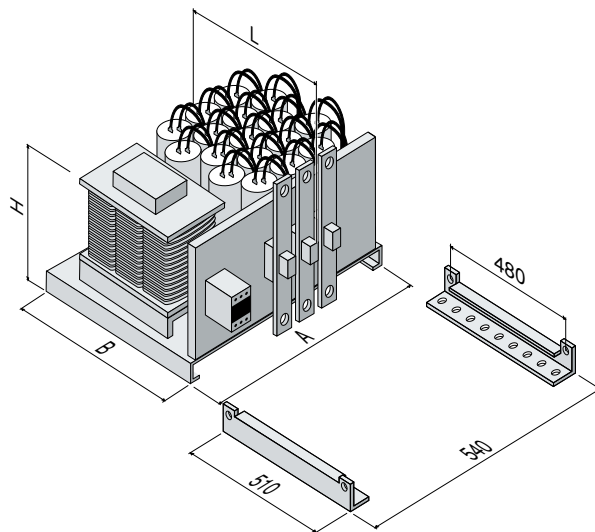

Power Factor Regulator BMR type



The BMR power factor correction regulator is designed with technology for the processing of the signals such to assure the careful control of all the electrical measures of the plant as: Voltage, current, Cos ϕ , THD% in current, ambient temperature probe side, active, reactive, apparent power, maximum values measured and through a reliable algorithmic calculation, a proper use of the capacitors and contactors, considering the distortions of the industrial plants. By means of digital technology of signals filtering, the regulator is able to separate from the harmonic components the only fundamental sinusoidal components such as tension and current on which the phase shift is measured. The automatic insertion sequence of the capacitors batteries does not work in sequential way, but according to the plant need and to the power of each single battery.

MAIN FEATURES

Supply voltage	380 ÷ 415 Vac \pm 10% (on request 220V)
Voltage range of measure	85 - 525 Vac
Rated frequency	50/60 Hz selecting
Rated consumption	5VA
Current signal	0,15 ÷ 5,5 A Ie from C.T. standard/5
Voltage signal	-40% +15% of the supply voltage (Max 525V)
Controlled banks	12
Power factor setting	0,85 lag ÷ -0,95 lead
Measurements	voltage, Current, cos ϕ , THD% of network, temperature
Digital Display	alphanumeric 4 rows at 16 characters backlight
Led	exit state relays of banks, MAN/AUT; State of the network: inductive or capacitive, fun
Relay contacts	banks/alerts 8A 250V (AC1), max switching 440V
Clamp strip	standard detachable
Working temperature	-20°C ÷ +55°C
Protection degree	IP41, with protection IP54 upon request
Main characteristics	case in ABS self-extinguish 144x144mm setting network current from 5 to 10.000 A measure of the true effective current/voltage value measure of THD% current up to the 32 nd harmonic measure of cos ϕ , on the fundamental voltage and current setup of level of intervention ventilation (FAN) setup over temperature level setup of cos ϕ , from 0,85IND to 0,95 CAP setup power kvar for each bank (0,1 ÷ 6000) setup of re-connection time (from 5 to 240s) setup nominal voltage of capacitors (from 80 to 650V) setup sensitivity of delayed intervention setup delayed intervention and instantaneous THD alarm setup of measure mode at 2 or 4 dials setup power for each bank (1 ÷ 6000 kvar) views: cos ϕ between voltage and current on the fundamental, voltage supply, current supply, true RMS, fundamental current supply, harmonic current, working temperature, probe side, THD% in current, maximum values, active, reactive and apparent power. Reactive power in surplus or missing in comparison to the setup value, Number of insertions for each bank
Option	serial port RS 485 (0,4A)
Reference standards	CEE 73/23 and 93/68 (low-voltage); CEE 89/336 and 93/68 (EMC); EN 61000-6-1/-2/-3/-4; EN 60335-1

Type	Supply voltage Volt	Controlled banks (n°)	Dimensions (mm)			Version
			B	H	P	
BMR6	380 ÷ 415	6	96	96	65	standard
BMR8	380 ÷ 415	8	144	144	75	
BMR12	380 ÷ 415	12	144	144	75	



Traditional automatic power factor correction equipment, where the banks of capacitors are controlled by contactors, has reduced functionality caused by the high in-rush over-currents:

- contactor deterioration
- further stress on the capacitors
- disturbance in the electrical networks

Besides, it has difficulties in responding to fast load variations.

As solution, COMAR Condensatori S.p.A. has designed, developed e manufactured AUTOMATIC STATIC P.F. EQUIPMENT where each bank of capacitors is activated by zero-crossing devices. This system is suitable if silent equipment is mandatory.

MAIN FEATURES

Rated voltage	415Vac for AAR/100 type (other on request up to 660Vac)
Rated frequency	50Hz
Insulation voltage	690V
Rated power	referred to rated frequency and voltage
Voltage of auxiliary circuits	12 Vdc Auxiliary circuits are fed by a suitable transformer
Max. temperature range	ambient +52°C
Cubicle	in robust sheet steel, RAL7032 painted (other on request)
Protection degree	IP 31 (IP 40 and IP 54 on request); indoor IP 00 (IP 20 on request)
Ventilation	forced
Supply	by means of isolating switch with door interlocking device. Cable entry from the bottom for G6E and G8E type

CAPACITORS SWITCHING

Each bank of capacitors is controlled by n°3 x opto isolated zero point firing and microprocessor

Max. insertion reaction time	200 ms
Fuses	every bank is protected by a set of three HRC fuses (NH00 type - curve gG) with high breaking capacity (100kA)
Capacitors	self-healing polypropylene metallized single-phase (MKP), equipped with overpressure safety device. Discharge resistors 200msecs. All are compliant with international standard and PCB free Internal connection: delta
Rated voltage	550Vac AAR/100 type capacitance tolerance: -5% / +10% total losses of the capacitors: $\leq 0,4$ W/kvar temperature category: -25 / D
Blocking reactors	iron core type with copper windings tuning frequency: 189Hz (p=7%) max. dissipation losses: 180W for 25kvar banks; 265W for 50kvar banks; 270W for 75kvar banks linearity: 1,3 In max. harmonic distortion of voltage allowed on the networks is THDV=3%
Regulator	type of measurement: VARMETRIC amperometric signal: C.T...../5 Amps voltmetric signal: from inside the cubicle switching on / off times: 0,5 sec.÷1sec serial output RS485
Reference Standards	capacitors: CEI EN 60831-1/2, IEC 831-1/2, UL810. Equipment: CEI EN 60439-1, IEC 439-1
Type of service	continuous for indoor operation

STATIC P.F. correction equipment

GE AAR/100 - ST Type - 415V - 50Hz

THDI_{max} on the network = 100%

Code	Qn (kvar)	Power of banks (kvar)	N. of steps (n. x kvar)	Switch (A)	Controller (type)	Dimensions bxpxh (mm)	Weight (kg)
G6E AAR/100-ST	75	25 25 25	3 x 25	160	MPR8	600 x 600 x 1600	150
G6E AAR/100-ST	100	25 25 50	4 x 25	200			170
G6E AAR/100-ST	125	25 50 50	5 x 25	250			200
G6E AAR/100-ST	150	25 50 75	6 x 25	315			220
G6E AAR/100-ST	175	25 50 50 50	7 x 25	400			250
G6E AAR/100-ST	200	25 50 50 75	8 x 25	400			270
G6E AAR/100-ST	225	25 50 75 75	9 x 25	500			300
G6E AAR/100-ST	250	25 25 50 75 75	10 x 25	500			330
G6E AAR/100-ST	300	25 50 75 75 75	12 x 25	630			390
G8E AAR/100-ST	350	50 75 75 75 75	7 x 50	800	MPR8	600 x 600 x 2000	480
G8E AAR/100-ST	400	50 50 75 75 75 75	8 x 50	800	MPR8	1200 x 600 x 2000	570
G8E AAR/100-ST	450	25 50 75 75 75 75 75	18 x 25	1000			620
G8E AAR/100-ST	500	50 75 75 75 75 75 75 75	10 x 50	1000			670
G8E AAR/100-ST	550	50 50 75 75 75 75 75 75 75	11 x 50	1250			720
G8E AAR/100-ST	600	75 75 75 75 75 75 75 75 75	8 x 75	1250			770
G8E AAR/100-ST	650	50 75 75 75 75 75 75 75 150	13 x 50	800 + 630			820
G8E AAR/100-ST	750	75 75 75 75 75 75 75 150 150	10 x 75	800 + 800			870
G8E AAR/100-ST	825	75 75 75 75 75 75 150 150 150	11 x 75	630 + 1000	MPR8	1800 x 600 x 2000	1060
G8E AAR/100-ST	900	75 75 75 75 75 150 150 150 150	12 x 75	630 + 1250			1150
G8E AAR/100-ST	975	75 75 75 150 150 150 150 150	13 x 75	800 + 1250			1240
G8E AAR/100-ST	1050	75 75 150 150 150 150 150 150	14 x 75	800 + 1600			1330



G4RM Type h1210 mm: Cabinet for floor mounting

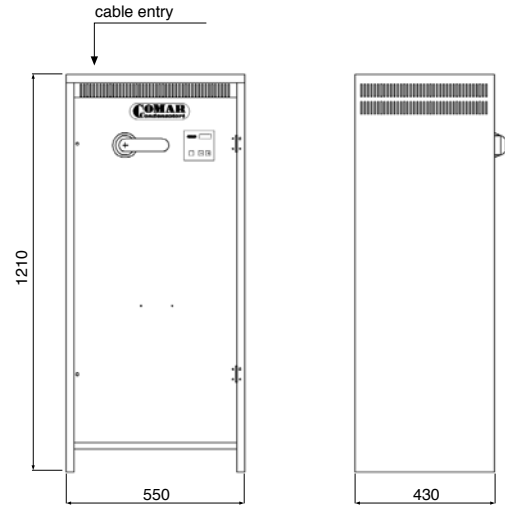

G6E Type h1600 mm: Cabinet for floor mounting

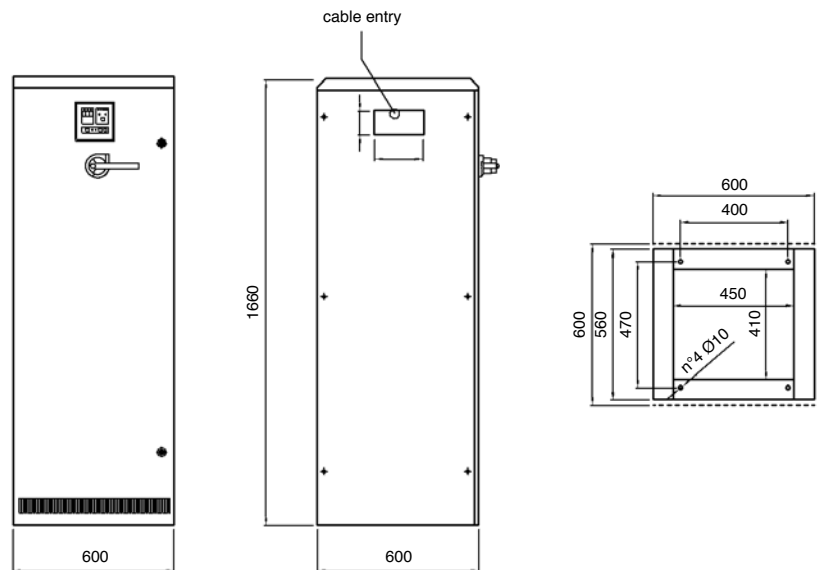

MODULAR SYSTEM

For P.F.C. equipments in h.1210 mm. cabinets, the banks of capacitors are fitted on racks. If it is required, in the future, each cubicle can be up-rated to its maximum power by fitting additional racks.

G8E Type h2000 mm: Cabinet for floor mounting

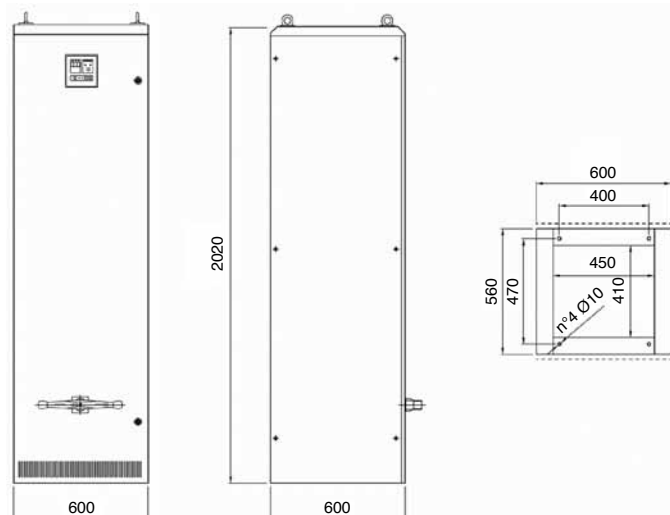

G8E Type h2000 mm: Cabinet for floor mounting

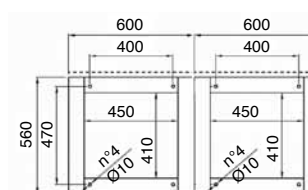
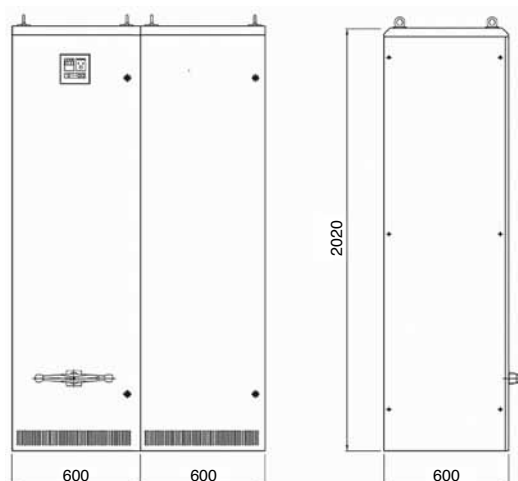

MODULAR SYSTEM

For P.F.C. equipments in h.1600 and h.2000 mm. cabinets, the banks of capacitors are fitted on racks which are connected together by copper bars. If it is required, in the future, each cubicle can be up-rated to its maximum power by fitting additional racks.

A further increase of the P.F. can be obtained with the addition of a master unit equipped with electronic regulator for the control of a future satellite unit with its own isolating switch.



PRODUCT PROFILE

Lighting capacitors,
Motor capacitors,
Capacitors for power electronics,
P.F. correction equipments,
Harmonics reduction filters,
Shunt active filters for active compensation of harmonic currents,
Harmonics analyser devices,
Ignitors for metal halide and sodium vapour lamps



COMAR CONDENSATORI S.p.A.

Via del Lavoro, 80 - 40056 Crespellano (Bologna) Italia
Tel. +39 051 733383 - Fax +39 051 733620
commercial: export@comarcond.com
technical: info@comarcond.com
www.comarcond.com

Local Agent in Kuwait

Sales, Commissioning and Technical Support



D H U F A R

Trading & Contracting Company

P.O. Box: 5720, Safat 13058 - Kuwait
Tel: (+965) 5714902 - 5714903 - Fax: (+965) 5714904
trading@dhufar.com - www.dhufar.com
marketing@dhufar.com