

LD-Drive: Bearing assemblies with Direct Drive

Compact, highly dynamic, efficient.



LD-Drive: Lightweight Bearing assemblies with Direct Drive

Franke Wire Race Bearings with integrated direct drive are characterized by maximum energy efficiency. The integration of the motor directly into the bearing makes it possible to dispense with components such as gears and drive pinions and thus complex lubrication circuits. The moving masses are significantly lower and performance loss due to friction is minimized.

The Franke wire race bearing principle also offers the advantage of free choice of material for the housing. The use of lightweight materials such as aluminum, plastic or carbon allows significant weight savings. The motor can be made smaller, resulting in energy savings of up to 30%.

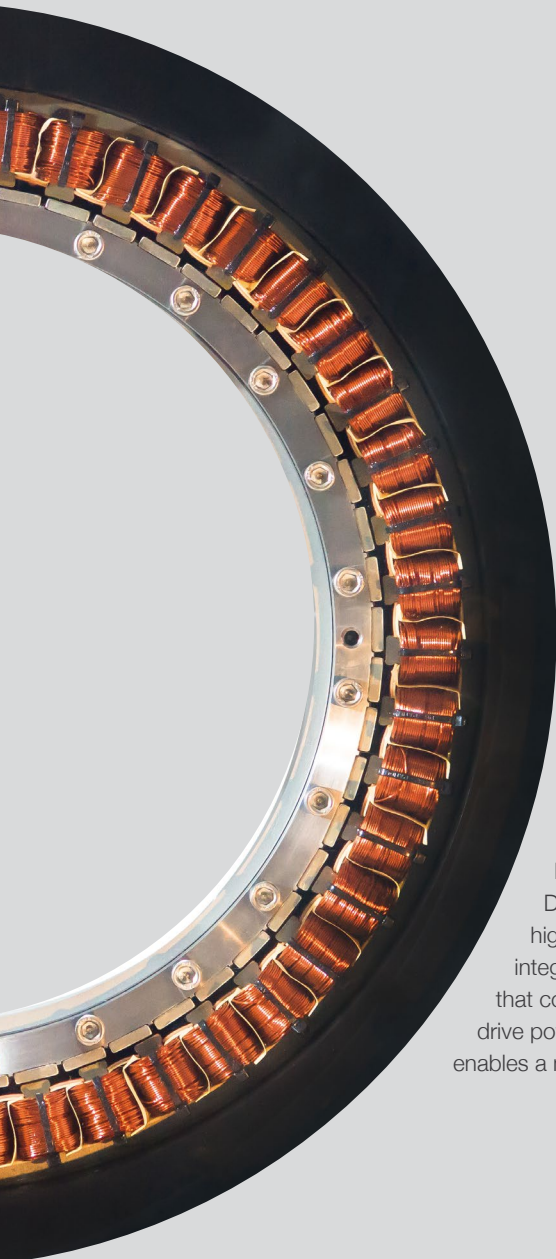

Advantages of Franke Direct Drive

- integrated system
- wear-free drive
- high torque
- highly dynamic, high efficiency
- bespoke design to customers request
- compact design
- motor, measuring system or controller freely selectable
- water cooling on request (doubling the nominal torque)

Application Examples

- Medical technique
- Automotive
- Navigation / antenna systems
- Pick & Place
- Assembly
- Automation

Maximum performance – compact design

Direct drive bearings are particularly suitable for applications in which high performance and small mounting space are important criteria. The integration of the complete drive system into the bearing housing means that components subject to heavy wear for the conventional transmission of drive power such as toothed belts, shafts or chains can be omitted. This also enables a more accurate positioning.

Technique in Detail: Wire Race Bearings create space for motorization

In the case of Franke wire race bearings, the rolling process does not take place directly between the balls and the surrounding construction, but rather on the integrated race rings. Their compact and heavy-duty 4-point-geometry gives you all possibilities of design and the freedom of choice regarding materials and geometries.

The drive is integrated directly into the housing. The stationary bearing part forms the stator, the moving bearing part acts as a rotor of the motor. There is no need for further or more complex components to initiate the rotation, which increases system efficiency and lifetime.

Design Example

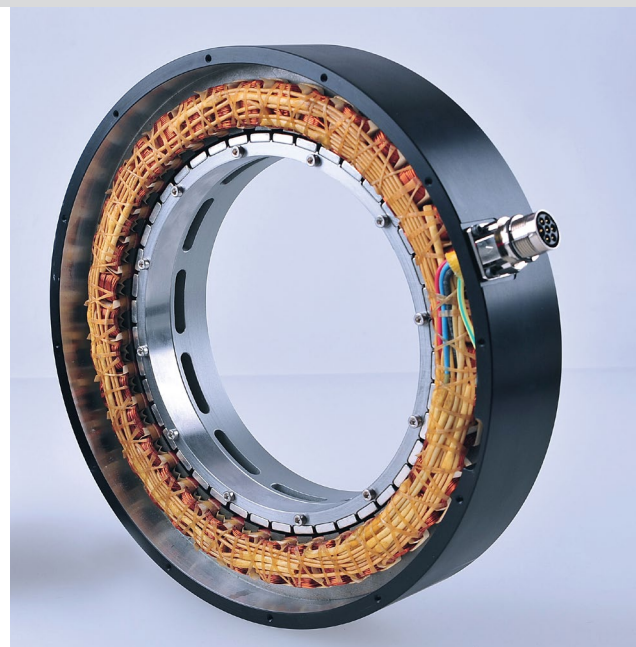
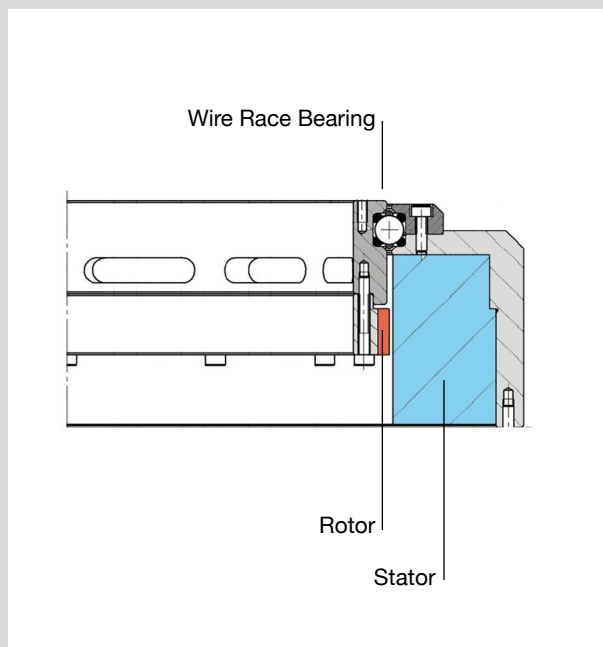

Technical Data

Outer diameter	280mm
Ball pitch diameter	180mm
Inner diameter	160mm
Height	73,5mm
Total weight	5,5kg
(Motor weight)	3,3kg)
Bearing type	4-point-bearing
Adjustment	free from preload
Material	Aluminum anodised
Material magnet ring	C45N

Direct Drive

Nominal torque	13Nm
Max. torque	60Nm
Nominal current	6A
Peak current	32A
Max. revolutions	200 rpm
Speed	0-200 rpm, adjustable
Voltage	230V
Optional	measuring system

Franke LD-Drive for medical technique: High End Bearings in the heart of CT-scanners

Franke Wire Race Bearings are the first choice of renowned manufacturers of CT scanners worldwide. Quiet, light and highly dynamic, they meet all the requirements of modern components for high-performance medical equipment. Here, the customers receive the complete assembly of lightweight bearing, motor and control system coordinated from a single source.

The main bearing of the computer tomograph is also responsible for providing accurate images. Even at high speeds it has to run quietly and with low vibration. An exact round and axial run must be guaranteed. Franke special bearings for computer tomographs achieve speeds of up to 300 rpm with a noise level of less than 60 dB (A). Their high precision and smoothness ensure excellent picture material through the X-ray unit.

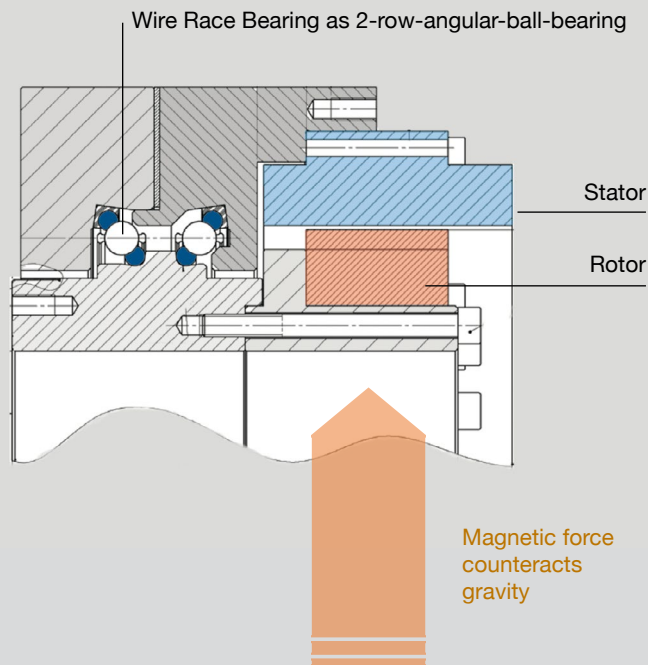
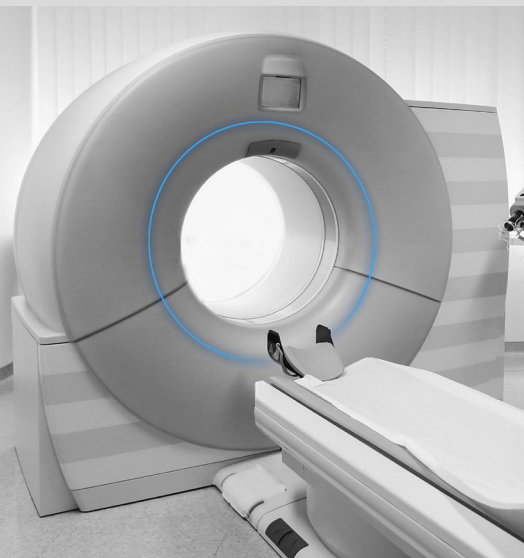

Franke CT-Scanner bearings 2020 - for computer tomographs of the future

Our test stands are already running next-generation CT bearings. These bearings are equipped with segmented drives and are already achieving speeds of 400 rpm at 70 db (A) under full load. Due to the technology of relieving the bearing by magnetic forces, a virtually unlimited service life can be achieved.

Competence from a single source: Drive system and bearing perfectly matched

Research and development are integral parts of our daily endeavors to provide you with the best possible solution for your application. We start development projects either together with our customers to develop specific solutions or on our own initiative to optimize our products. In our laboratories in Aalen, Germany, we have extensive equipment to carry out any kind of tests and analyzes.

Franke wire race bearings and linear systems adapt to your application. We are happy to advise you on construction and design. Talk to us about your planned application or let us know in advance, with the help of our team of product advisors, what you need. We evaluate your information and make you a proposal for free and without obligation.

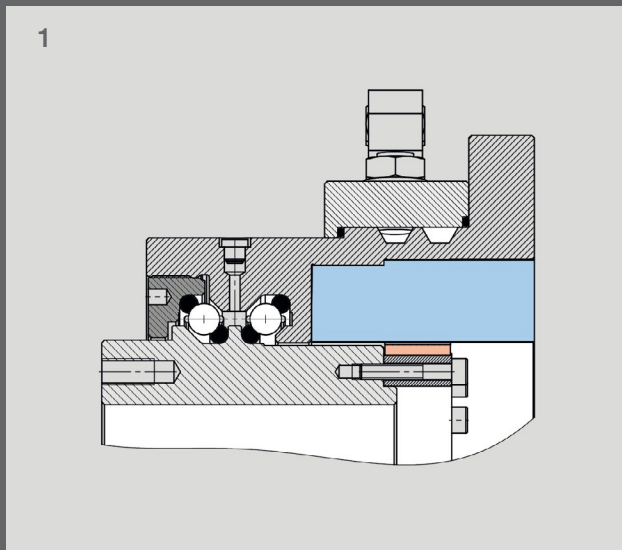

1. LD-Drive in steel version with water cooling. KKØ 300mm, nominal torque 163 Nm, maximum torque 328 Nm.
2. LD-Drive in aluminum version. KKØ 290mm, nominal torque 55 Nm, maximum torque 246 Nm.
3. LD-Drive in steel version. KKØ 150mm, nominal torque 12 Nm, maximum torque 40 Nm.

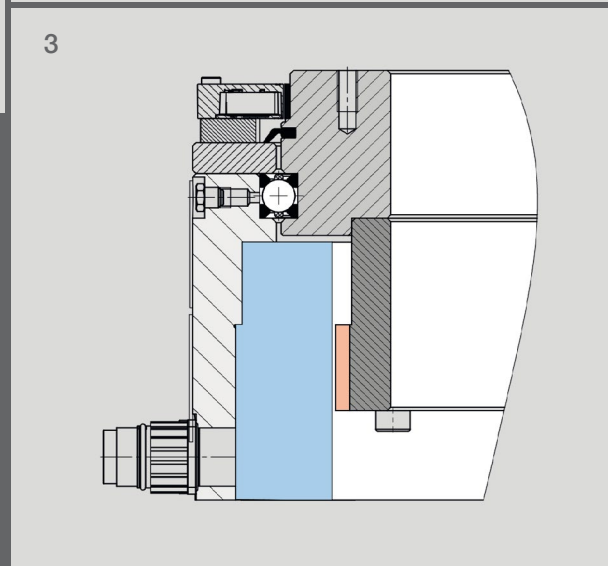
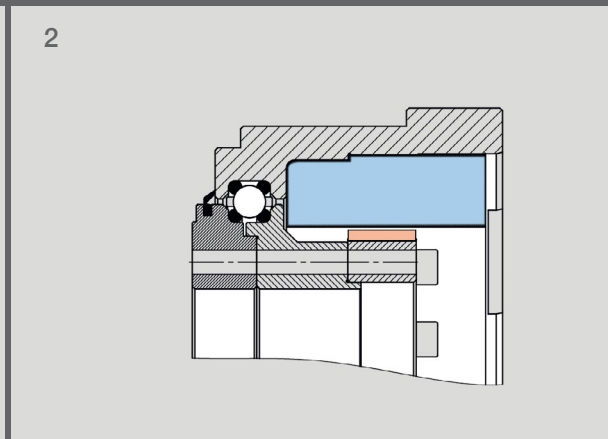

A black and white photograph of a man in a dark suit and light shirt, standing in a factory. He is holding a large, intricate bearing assembly with both hands. In the foreground, several large, polished metal cylindrical components are visible. The background shows industrial machinery and a blurred factory floor.

„If you have any questions about our bearings of the LD-Drive type, I am happy to help.“

Grad. Engin. (BA) Peter Niemeyer, R&D Bearing Assemblies
Phone +49 73661 920-172, p.niemeyer@franke-gmbh.de

FAQ

Type / conditions of use

1. Which diameters can be realized with direct drives?

Diameters from 100 to 2000mm are possible.

2. Up to which temperatures can LD Drive bearings be used?

Up to 120° C.

Motorization

3. How are the motors protected against thermal overload?

There are several sensors available that can be integrated into the motor:
PTC thermistor (standard) / KTY / Twilling switch (bimetal switch)

4. What advantage does a motor with water cooling offer?

The nominal torque is doubled. This reduces the size of the system.

5. How does the motor react in the event of a power failure?

Motor and bearing are slowing down. Optional: braking system for fast stop or controller with safety function.

6. How are the cables of the motor assembled?

The cables are assembled according to customer requirements with or without plug.

7. Which IP protection class do the direct drives achieve?

Due to the nature of the wire race bearings, a protection class of IP41 can be achieved.

8. Are NFPA or UL standards met for the US market?

It is possible to equip the motor insulation system with UL listed materials.

9. Which documentation is included with the motors?

General notes, safety instructions, connection diagrams and installation/maintenance manual.

Controller / measuring system

10. Which controllers can be used with torque motors?

Each controller can be used, e.g. Elmo, BoschRexroth, Kollmorgen, Siemens, ...

11. Which measuring systems can be used?

Every measuring system can be used.

12. How are the measuring systems fixed?

The measuring tape is mounted directly on the rotor and the measuring head on the stator. Alternatively, it is possible to attach the measuring system to the mating structure.

13. What restrictions are there with the measuring systems?

Since the measuring tape is a closed ring, only certain diameters are available here, which must be taken into account in the design. For larger quantities, any diameter is feasible - but with one-time additional costs.

Franke GmbH
Obere Bahnstraße 64
73431 Aalen, Germany
Phone +49 7361 920-0
Fax +49 7361 920-120
info@franke-gmbh.de



www.franke-gmbh.com
www.frankedirectdrive.com/en/

