



AEROTECH

Dedicated to the Science of Motion

Integrated Automation Solutions

PLC

Fieldbus
and
I/O

Motion
Control

Software
Development
Tools

Motors
and
Drives

Operator
Interface

High-Speed
Data
Acquisition

Aerotech Worldwide

United States • France • Germany • United Kingdom • China • Japan • Taiwan

Contents

WORLD HEADQUARTERS

Aerotech, Inc.

101 Zeta Drive, Pittsburgh, PA 15238
Ph: 412-963-7470 • Fax: 412-963-7459
Email: sales@aerotech.com

Aerotech, Ltd.

Jupiter House, Calleva Park, Aldermaston,
Berkshire, RG7 8NN, UK
Ph: +44-118-9409400 • Fax: +44-118-9409401
Email: sales@aerotech.co.uk

Aerotech GmbH

Südwestpark 90, 90449 Nürnberg, Germany
Ph: +49-911-9679370 • Fax: +49-911-96793720
Email: sales@aerotechgmbh.de

Aerotech KK

17-25 1-chome, Kitahoncho Funabashi-shi,
Chiba-ken, 273-0864, Japan
Ph: +81-47-489-1741
Email: sales@aerotechkk.co.jp

Aerotech China

Unit 3315, 33/F, China Merchants Tower,
168 Connaught Road Central, Hong Kong
Ph: +852-3793-3488
Email: saleschina@aerotech.com

Aerotech Taiwan

1F No. 42 Lane 128, Jingye 1st Road,
Taipei City, 10462 Taiwan (R.O.C.)
Ph: +886-02-8502-6651
Email: sales@aerotech.tw

Aerotech France

BP 70043, 45702 Villemandeur Cedex, France
Ph: +33-238970830
Email: sales@aerotech.co.uk

	Introduction
4	Aerotech Integrated Automation Solutions
	Motion Composer Software
7	Setup and Configuration
9	Advanced Diagnostic and Tuning Capabilities
15	Integrated Development Environment and .NET
18	Integrated Automation: MotionPAC - PLC and Motion
30	Operator Interface
31	Software Architecture
	Controller Architecture
32	Automation 3200 Digital Automation Platform
34	Ensemble Stand-Alone Multi-Axis Controller
36	Soloist Stand-Alone Single-Axis Controller
38	Controller and Drive Technology
	Controller Features
46	Standard Control Capabilities
50	Advanced Control Capabilities
61	Fieldbus and Networking
	Quick Reference
64	Controller Comparison Chart
68	Hardware Comparison Chart
70	Servomotors
	Corporate Overview
73	Markets and Industries
80	Worldwide Training and Support
81	ISO Certification
82	Aerotech at a Glance

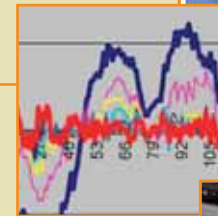

Aerotech's

Advanced Automation Technologies: 40 years in the making... and going strong...

- Controls
- Software
- Amplifiers
- Motors
- PLC
- Fieldbus
- I/O
- Vision
- Peripherals
- Robotics
- Data Acquisition

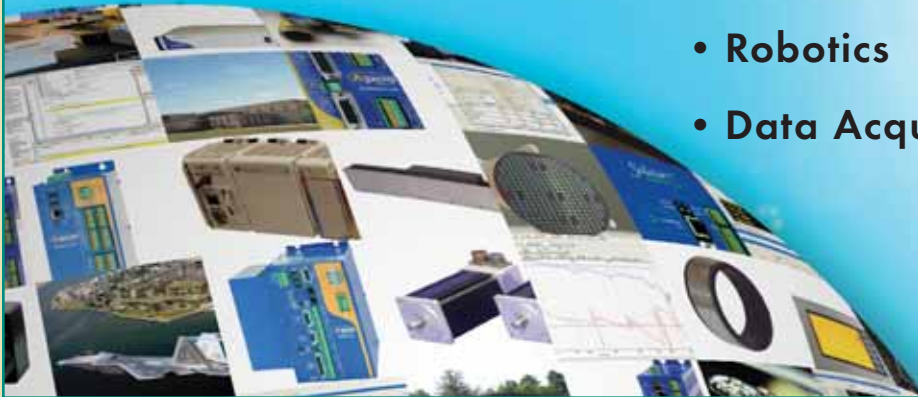

Aerotech Integrated Automation Solutions

- High performance
- Easy to use
- Flexible
- Scalable
- Networked
- Lowest cost of ownership
- Advanced control technology

Common Software Platform: Tools, Powerful Programming

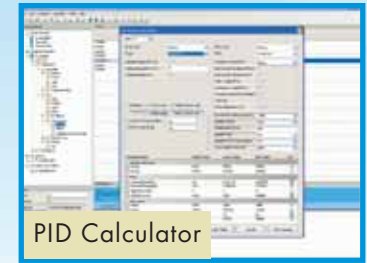
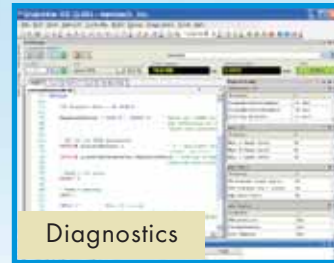

Develop your own applications with .NET, C#, VB.NET, C,

Award-Winning Controllers



Automation 3200

- PC-based
- 1 to 32 axes of coordinated motion
- Up to 32 tasks
- RS-274 (G-code)
- Advanced features for demanding applications
- PWM or linear drives (up to 150 A)
- Scanner control for marking
- Tightly integrated laser functionality
- Retro-fit package for old controls
- Integrated PLC and Motion - MotionPAC

Ensemble™

- Stand-alone
- 1 to 10 axis controller
- Up to 4 tasks
- Versatile, cost-effective, coordinated motion
- PWM or linear drives (10-150 A peak)
- Drives brushless, linear, rotary, DC brush or stepper motors
- Desktop, rack mount or panel mount

Configure Your Automation Solution with Aerotech

Environment, Calculators, Diagnostics

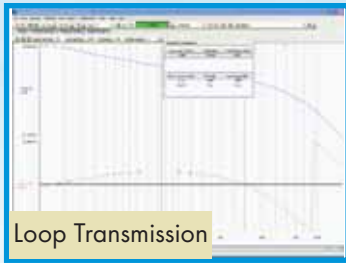

Linear and Rotary Servomotors



LabVIEW®, Tango, AeroBasic™ or PLC languages



Soloist™

- Stand-alone
- Network up to 1024 single axes
- Up to 4 tasks
- Elegant, economical, versatile controller
- PWM or linear drives (10-150 A peak)
- Drives brushless, linear, rotary, DC brush or stepper motors

Fieldbus and Network Connectivity

- EtherNet/IP™
- PROFINET
- Modbus®/TCP
- RS-232
- EtherCAT™
- Ethernet TCP/IP
- USB
- GPIB

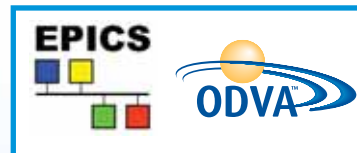

Data Acquisition

Sensor Fusion

- Collect motion and I/O signals at exactly the same time



Accessories



Scalable Automation Control Software for Simple Applications and the Power User

**Motion Composer: Use the same
Aerotech software with the
A3200, Ensemble, or Soloist**

- Configuration Manager to organize your applications
- Calculators for quick and easy setup
- Extensive diagnostics for commissioning
- Integrated Development Environment for fast development
- Data Acquisition and Analysis Tools for increasing performance
- Fully compliant .NET 2.0 shortens the development cycle

Integrated Configuration Manager for Easy Setup

The screenshot shows the Ensemble Aerotech software interface. On the left is a Network Explorer pane showing a tree view of controllers and parameters. The main window displays a 'CfgMotType Parameter' configuration screen with a table of motor settings and a help section. Callout boxes point to various features:

- Standard Windows® menus
- See all the controllers on the network
- Work with this controller
- Network Explorer for project management
- File space on the controller
- Extensive calculators for system setup
- Compare parameter files
- Tool tips
- Standard motion toolbars
- Configurable workspace with your preferences
- Context sensitive integrated help
- Hyperlink to associated subjects

Mode	Motor Type
0	AC brushless with Hall effect switches
1	AC brushless without Hall effect switches ⁽¹⁾
2	DC brush

Calculators for Quick and Easy Setup

Current loop calculator

PID gain calculator

Configure feedback for user units

Easily switch axis to be configured

Select your motor or add a custom motor

System knows all parameters of Aerotech components

Select amplifier type

Directly enter any parameter values here

Summary of default, current and new values for all parameters

The screenshot shows the 'Parameter Calculator' window. At the top, there's a dropdown menu for 'Axis' with 'Axis 1' selected. Below it, there are three tabs: 'Feedback', 'Servo Loop', and 'Digital Current Loop', with 'Digital Current Loop' being the active tab. The 'Feedback' section has 'Invert Direction' set to 'No' and 'Units' set to 'deg'. The 'Digital Current Loop' section has 'Encoder Resolution (pulses/rev)' set to 1000 and 'Amplifier Type' set to 'CP'. At the bottom, there's a table with columns for 'Parameter Name', 'Default Value', 'Current Value', and 'New Value'. The table lists parameters for 'Digital Current Loop', 'Motor', and 'Servo Loop'. A 'Calculator' window is open in the background.

Parameter Name	Default Value	Current Value	New Value	Set
Digital Current Loop				
GainK	8000	8000	2000	[Set]
GainP	51000	51000	1000	[Set]
Motor				
ThresholdVgAmp	2.6	2.6	2.357143	[Set]
ThresholdClampAmp	10.5	10.5	5.357142	[Set]
Servo Loop				
GainK	6000	600	3000	[Set]
GainP	44000	44000	140000	[Set]

Extensive Diagnostics for all System Signals and Variables Shortens Debug and Startup Time

The screenshot shows the Ensemble software interface with several callout boxes pointing to specific features:

- System toolbar for system control**: Located at the top left of the main window.
- Axis toolbar for control of each axis**: Located below the system toolbar, showing controls for X, Y, Z, and U axes.
- Standard toolbar for program control**: Located at the top right of the main window.
- Issue immediate commands without operator interface open**: Located at the top right, pointing to a specific button.
- Control all axes at once**: Located on the left side, pointing to a button in the axis toolbar.
- Multiple tabs for organized programming**: Located on the left side, pointing to the task tabs.
- View task status as needed**: Located on the left side, pointing to the task list table.
- Watch any variables as the program runs**: Located on the left side, pointing to the diagnostic display.
- Pop-up error reporting**: Located on the left side, pointing to a message box.
- Compiler output screen**: Located on the left side, pointing to a window.
- Dockable windows for custom work environment**: Located on the right side, pointing to the diagnostic display.
- Configurable to see only the information you want**: Located on the right side, pointing to a filter button.
- Real-time readout of system state variables**: Located on the right side, pointing to the diagnostic display.
- Real-time access to system signals**: Located on the right side, pointing to the diagnostic display.
- Real-time reporting of all faults**: Located on the right side, pointing to the diagnostic display.
- Real-time system information**: Located on the right side, pointing to the diagnostic display.

The main interface displays the following data:

Axis	Speed	Position Command	Velocity Command	Status
X	Speed 3600	5716.2600 deg	0.0000 deg/s	Enabled
Y	Speed 3600	-2210.4000 deg	0.0000 deg/s	Enabled
Z	Speed 3600	-1508.4000 deg	0.0000 deg/s	Enabled
U	Speed 3600	-6505.2000 deg	0.0000 deg/s	Enabled

The diagnostic display shows the following data:

Property	Value	Unit
Position Command	-43314.000	mm
Position Feedback	-43312.000	mm
ProgramPosition	-1714.000	deg
ProgramPosition	-6305.200	deg

The task list shows the following data:

Task	Status	Err
Auxiliary Task	Inactive	
Task 1	Inactive	Application/Enabled Axis currently disabled
Task 2	Inactive	
Task 3	Inactive	
Task 4	Ready	

Advanced Diagnostic and Tuning Capabilities Minimize Startup Time and Allow Easy Optimization of Motion



Use Encoder Tuning Tool to Increase System Accuracy

One click tuning

Fully integrated with controller

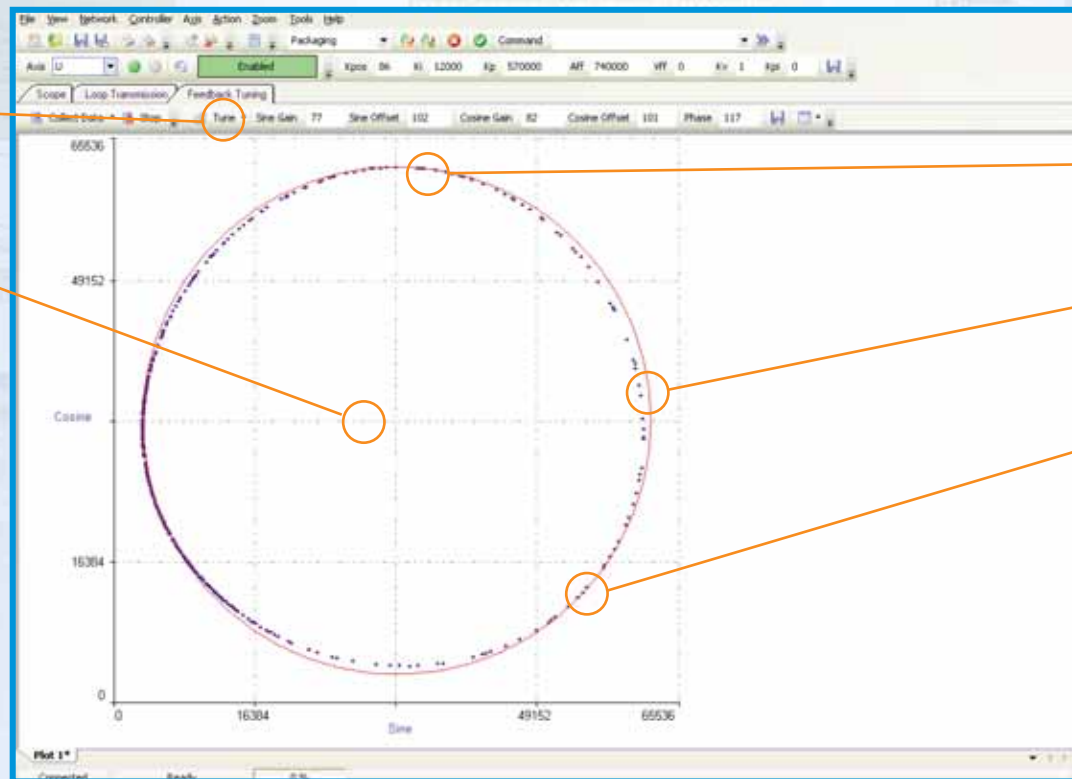

Optimally calculates gain and phase of amplified sine encoder channels in seconds

Actual encoder performance

Graphical display of the Lissajous plot to optimize the encoder signal

Loop Transmission is a Tuning and Diagnostic Utility that Greatly Enhances System Performance

Graphical loop shaping – add filters or change gain by dragging the gain curve, and the filter coefficients and PID gains are calculated automatically

Frequency response between any two system state variables*

Open or closed loop response

Analyze position loop, velocity loop or current loop

Cross-axis loop transmission to optimize multi-axis performance*

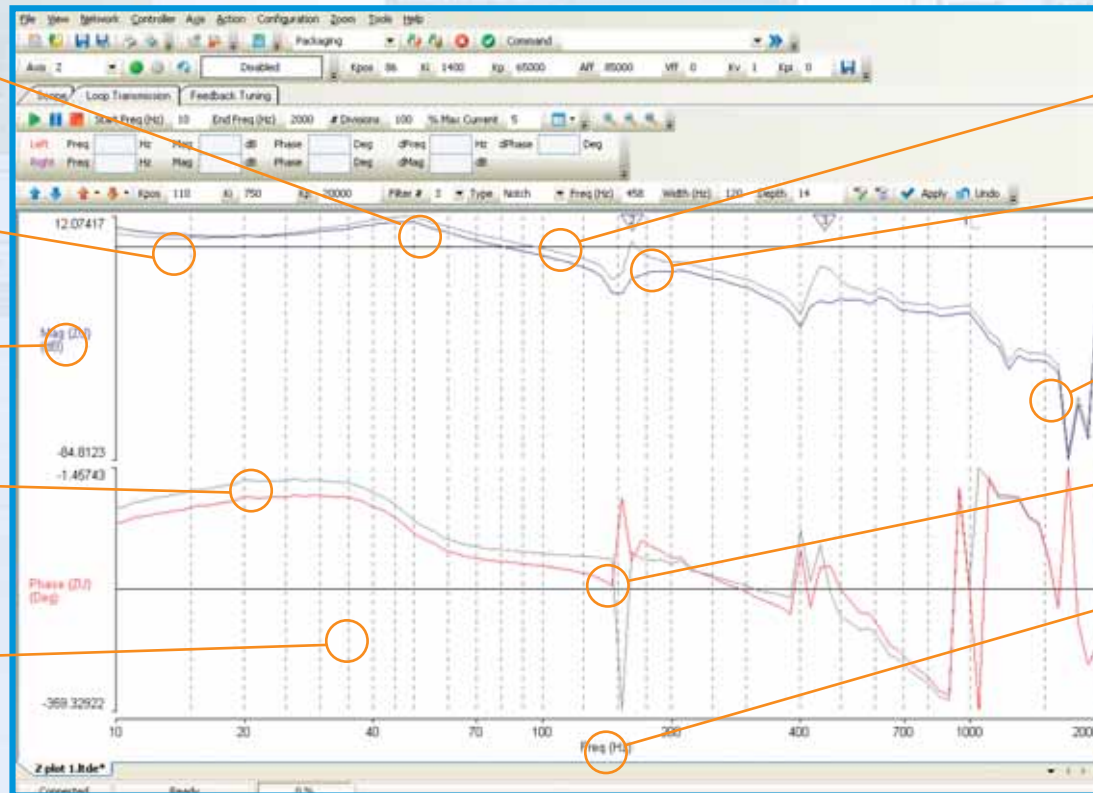

Automatic calculation of gain margin

Identify resonances and use filters

Calculator and loop shaping to increase performance

Automatic calculation of phase margin

System frequency response or Bode plot

*Coming Soon

Fully Integrated Digital Filter Calculator Makes Performance Enhancements Easy

Axis selection

Select your filter type: low pass, high pass, notch, resonant, lead/lag

Add up to eight filters per axis

Discrete time gains are automatically calculated and stored in the parameter file

Configure filters for your application by specifying frequency, depth and width

Cursor control to read out gain and phase

Composite frequency response of all filters

Store all parameters in the parameter file

Digital Filter Calculator

Axis: X

Filter 1 Type: LowPass
Filter 2 Type: Notch
Filter 3 Type: Resonant
Filter 4 Type: None

Filter 1 Parameters: Cutoff Freq (Hz): 1000
Filter 2 Parameters: Center Freq (Hz): 1000, Width (Hz): 50, Depth (dB): 40
Filter 3 Parameters: Center Freq (Hz): 100, Width (Hz): 50, Gain (dB): 20
Filter 4 Parameters:

Filter	N0	N1	N2	D1	D2
Filter 1 Coefficients	0.226153999567032	0.452306989585103	0.226153999567032	-0.280945986509323	0.185561001300812
Filter 2 Coefficients	0.980937453794024	-2.17769114479404E-16	0.980552351850469	-2.17769114479404E-16	0.961488805644493
Filter 3 Coefficients	1.03435124810707	-1.96783705291467	0.958015141302473	-1.96783705291467	0.992366389309541
Filter 4 Coefficients	1	0	0	0	0

Left: Freq 146.17 Hz, Mag 1.41 dB, Phase -40.67 Deg
Right: Freq 1079.7 Hz, Mag -7.38 dB, Phase -110.93 Deg
dFreq -933.51 Hz, dPhase -70.26 Deg
dMag 8.79 dB

Magnitude (dB) vs Frequency (Hz) graph showing a notch at 1000 Hz and a resonance at 100 Hz.

Buttons: Remove, Accept, Cancel, Apply

Integrated I/O Panel for Debug, Commissioning or Operations

View I/O axis information and program at the same time

Monitor digital I/O control

Monitor analog I/O

Set digital I/O during test and commissioning

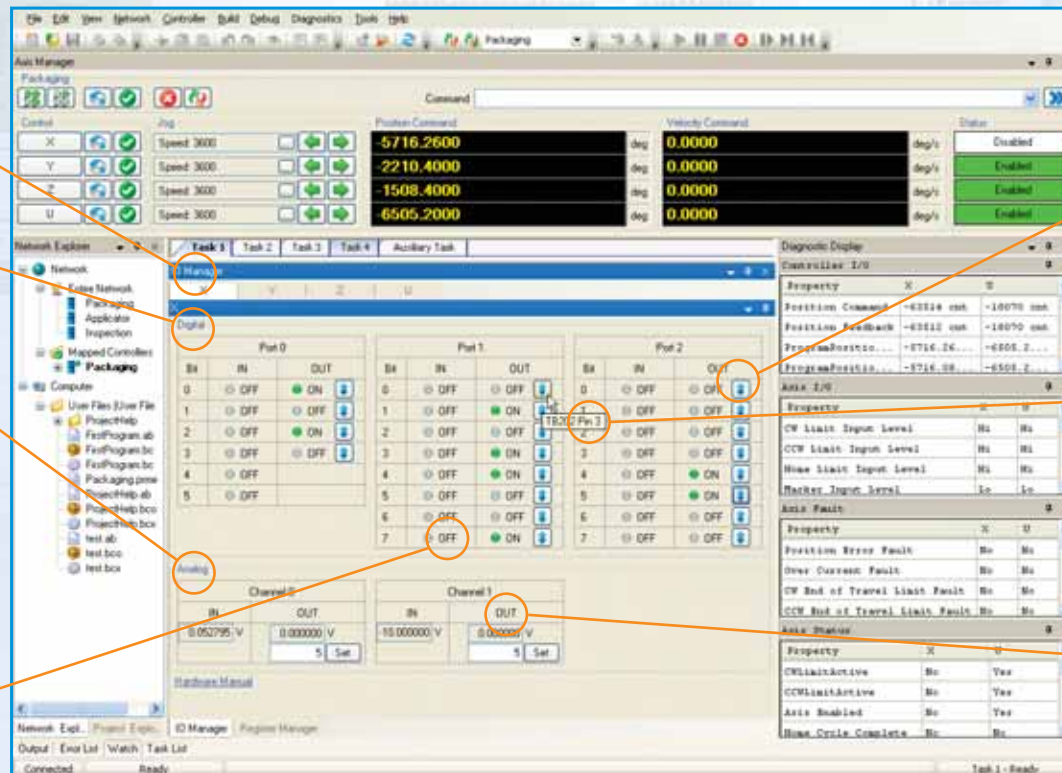

Use the I/O panel during programming to test as you go

Tool tip provides physical connector and pin on the drive to easily associate electrical wiring with software variables

Set analog I/O during commissioning for easy testing

Integrated Development Environment Shortens Development Time

Hide the axis manager while programming to see more code

Visual Studio®-like project management for advanced programming

Powerful IntelliSense® capability

Insert breakpoints to debug program

Low learning curve with strict implementation of .NET naming conventions

Detailed error explanation in error list

Minimize development time with debug features, break point, step in and step over

Full diagnostic instrumentation while debugging

Watch window shows variable values for easy debugging

Link to help file for description of error

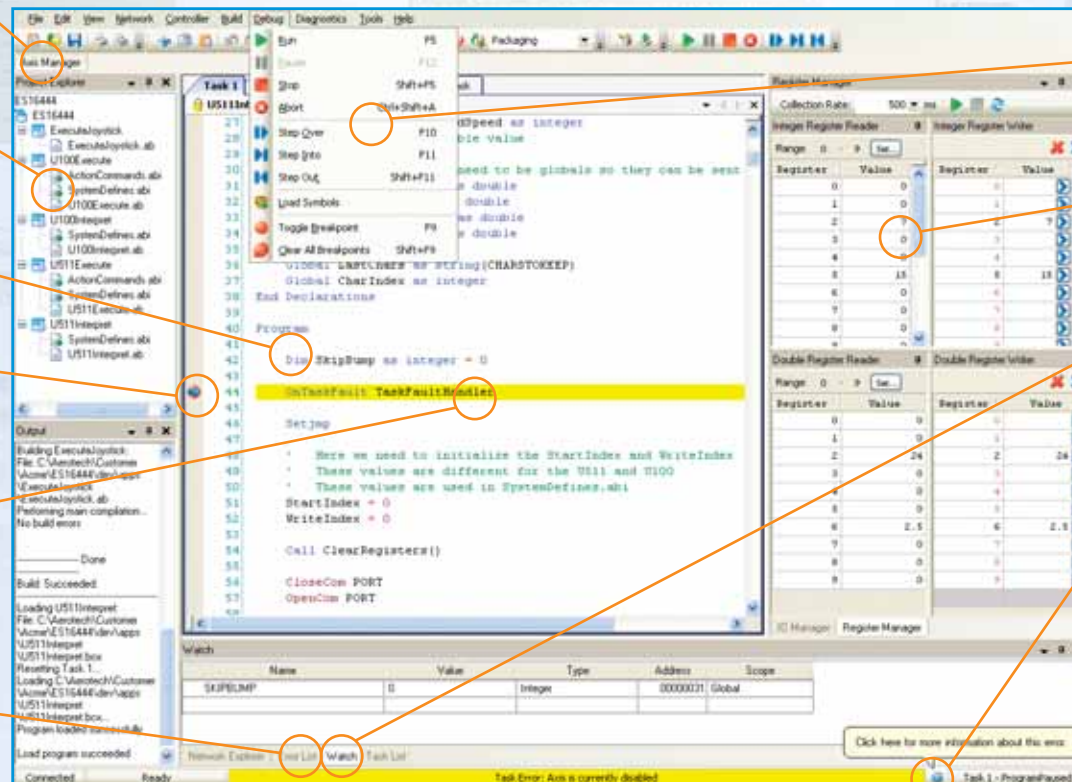

Create Reusable Modules with AeroBasic™

Create reusable code with libraries and #include files

Write easy-to-read and maintainable code by using #define (rather than numeric constants)

```
1 Header
2 #include "DisplayLibrary.h"
3 #include "PartLibrary.h"
4
5 #define QUIT_PARTS_PROGRAM -1
6 #define ADD_NEW_PART 0
7 #define MAKE_PART 1
8
9
10 #end Header
11
12 Program
13
14 Dim PartID as Integer
15 Dim PartCount as Integer
16 Dim UserAction as Integer
17 Dim PartsMade as Integer
18
19 "If the user selects to quit (from the display then negative one is returned"
20 while UserAction <> QUIT_PARTS_PROGRAM
21   UserAction = GetDisplayAction()
22
23   if UserAction = ADD_NEW_PART then
24
25     "User has selected to enter new part information
26     Call AddUserDefinedPart()
27
28   elseif UserAction = MAKE_PART then
29
30     "First get the ID of the part they would like to make
31     PartID = GetPartID()
32     "Get the number of parts they would like to make
33     PartCount = GetPartCount()
34     "Call the function to actually make the parts
35     PartsMade = MakeParts(PartCount, PartID)
36     "Show the parts count on the display
37     Call DisplayPartCount(PartsMade)
38
39   end if
40 end while
```

Real-time code environment

Advanced programming techniques result in code that is easy to read, simple to maintain and reusable for other projects

Protect intellectual property by using a library; permit or deny end users access to source code

Built-in software security key for OEMs

Create Easy to Maintain Code with AeroBasic™

User defined variable types allow an object-oriented approach to system design

Use structures to define your own data types

Advanced variable types such as arrays and strings allow for more advanced program design

```
1 Declarations
2   Structure to define a rectangular part with round corners
3   Type Part
4     ID          as Integer
5     CornerRadius as Double
6     Width       as Double
7     Length      as Double
8     End Type
9   Global: PartList(100) as Part
10  End Declarations
11
12 Function CutPart(hypval PartToCut as Part)
13   Move X Y
14   If PartToCut.CornerRadius = 0 then
15     Linear X PartToCut.Length F 100
16     Linear Y PartToCut.Width F 100
17     Linear X (-1)*PartToCut.Length F 100
18     Linear Y (-1)*PartToCut.Width F 100
19   else
20     Velocity On
21     Linear X PartToCut.Length F 100
22     CW X PartToCut.CornerRadius Y PartToCut.CornerRadius R PartToCut.CornerRadius
23     Linear Y PartToCut.Width F 100
24     CW X PartToCut.CornerRadius Y (-1)*PartToCut.CornerRadius R PartToCut.CornerRadius
25     Linear X (-1)*PartToCut.Length F 100
26     CW X (-1)*PartToCut.CornerRadius Y (-1)*PartToCut.CornerRadius R PartToCut.CornerRadius
27     Linear Y (-1)*PartToCut.Width F 100
28     Velocity Off
29     CW X (-1)*PartToCut.CornerRadius Y PartToCut.CornerRadius R PartToCut.CornerRadius
30   end if
31 End Function
32
33 Function MakeParts(hypval TotalParts as Integer, hypval PartID as Integer) as Integer
34   dim PartIndexToMake as Integer = 0
35   dim PartCount as Integer = 0
36
37   while PartID <> PartList(PartIndexToMake)
38     MakeToMake = ...
39   end while
40 End Function
```

Memory management is done by the operating system

Keeping all motion code in one function creates modularity, which brings products to market faster and reduces maintenance cost

Variable initialization reduces code size and increases readability for multiple developers

Standard program flow:
while/wend
for/next
repeat
if/then/else

Integrated Automation: MotionPAC

- 30% to 50% reduction in development time
- High-performance motion fully integrated with standard PLC environment
- Easy-to-use diagnostics and tools
- Standards & Flexibility: IEC 61131-3, .NET, PLCopen, PC-based

Program in IEC 61131-3: LD, FBD, ST

The screenshot displays the MotionPAC software interface with several key components highlighted by callouts:

- Define hardware**: Points to the hardware configuration section at the top.
- Online mode displays all Tag values**: Points to the data table at the top right showing numerical values.
- Create libraries**: Points to the Project View tree on the left.
- Axis manager**: Points to the 'Axis' tab in the top right.
- Standard LD**: Points to the Ladder Logic (LD) diagram in the main workspace.
- Combine LD and FBD in the same program**: Points to a specific logic element in the diagram.
- Tag database**: Points to the 'Common Elements' list on the right.
- LD, FBD or ST programs**: Points to the main workspace area.
- Completely integrated motion blocks**: Points to a motion control block within the diagram.

Tag Name	Value
Speed 1	0.0000
Speed 2	0.0000
Position	0.0000
Velocity	0.0000

Integrated Automation: MotionPAC – PLC and Motion



HMI

- Program selection and run
- Jog panel
- Machine control
- Customizable buttons
- Axis manager



MotionPAC

- IEC 61131-3
- PLCopen
- Aerotech motion blocks
- Axis manager
- Extensive development & debug environment
- Simulate program



Central Machine Tag Database

- Tags available in all applications by name
- Define both local or global machine Tags
- Define Tags in I/O definition, ST, LD, FBD or motion program



Motion Composer

- Axis manager
- Low-level motion diagnostics
- Motion programming
- Advanced control algorithms



I/O & Data Acquisition

- High-speed data acquisition synchronized with motion & PLC
- High-speed registration
- Position Synchronized Output
- Machine interlocks
- Fieldbus I/O

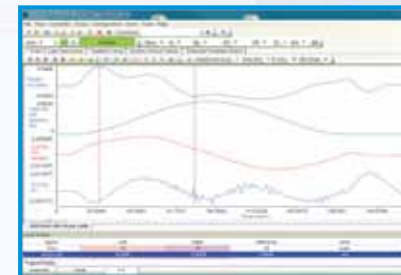

Scope

- Signal capture & analysis
- Autotuning
- Loop transmission
- Encoder tuning
- Advanced controls

Use Tags in Operator Interface by Name

The screenshot displays the A3200 CNC Operator Interface with the following sections:

- Control:** X, Y, Z, U, A axes with directional buttons.
- Status:** Homed status for X, Y, Z, U, A and V (Disabled).
- Program Position Feedback:** X: 69.355, Y: -69.355, Z: 0.694, U: -69.355, V: 0.000.
- Velocity Feedback:** X: 24.441, Y: -24.441, Z: 0.244, U: -24.441, V: 0.000.
- Executes Task Command:** Command field and Run Mode (Auto, Change, Off).
- Configuration:** Jog Pad, Velocity (Low, High), Jog Type (Freerun, Distance, Distance Hold), and Axis (X, Y, Z, A) settings for Distance and Velocity.
- Program Editor:** Shows G-code including G70, G75, F100, and G90 G1 X10 Y-10 Z.1 U-10.0.
- Axis Control:** Buttons for Enable/Disable X, Y, Z, U with associated keyboard shortcuts.

View CNC code running at same time as PLC code

Use shared Tags defined in MotionPAC by name in a button action

Use shared Tags by name in program called by a button click

Standard PLC Functions: IEC 61131-3

Ladder Diagram

- VALUE
- TRUE
- FALSE
- COMMENT
- CONNECTOR
- JUMP
- LABEL
- RETURN
- CONTACT (NO, NC)
- COIL
- LEFT POWERRAIL
- RIGHT POWERRAIL

Function Blocks

- CTD
- CTU
- CTUD
- F_TRIG
- R_TRIG
- RS
- SR
- TOF
- TOF_R
- TON
- TON_R
- TP
- TP_R

Motion Blocks (Partial List)

- MoveAbsolute
- MoveRelative
- MoveSuperimposed
- MoveVelocity
- Home
- Stop
- PositionProfile
- MoveContinuous
- Halt
- CamIn/CamOut
- CamTableSelect
- GearInPos
- GearIn/GearOut
- Phasing

Administrative Motion Blocks (Partial List)

- ReadStatus
- ReadAxisError
- ReadParameter
- WriteParameter
- ReadActualPosition
- AbortTrigger
- ReadDigitalInput
- ReadDigitalOutput
- WriteDigitalOutput
- SetPosition

Functions (Partial List)

- ABS
- ACOS
- B_BCD_TO_DINT
- B_BCD_TO_INT
- DELETE
- DINT_TO_BOOL
- EXP
- EXPT
- FIND
- GE
- GE_STRING
- INT_TO_BOOL
- INT_TO_BYTE
- INT_TO_DINT
- INT_TO_DWORD
- LE
- LE_TRING
- LEFT
- LEN
- MULTIME
- NE
- OR
- REAL_TO_BOOL
- SEL_TO_BOOL
- SEL_TO_BYTE
- TRUNC_SINT
- UDINT_TO_BOOL

One I/O and Data Dictionary for the Machine

I/O defined in one place

Drive I/O connected to system

Fieldbus I/O connected to the system

Easily map I/O to program Tags

Memory management automatically done by the MotionPAC

I/O available in all applications: scope, configurator, MotionPAC (PLC) and Motion Composer

From	Signal	I/O	I/O	To	Signal	Type
PLC	eCLR.LDSample1.mfo	←	→	Drive IO	HWIO\NServo\Signal5	WO...
PLC	eCLR.digOut	→	←	Drive IO	HWIO\NServo\Signal3	BOOL

Name	Type	I/O
mfo	WORD	→

I/O	Name	Type
→	Signal3	BOOL
←	Signal4	INT
←	Signal5	WORD

Use Scope to Plot any Motion, PLC, I/O, Variable or Tag

Motion variables

PLC Tags

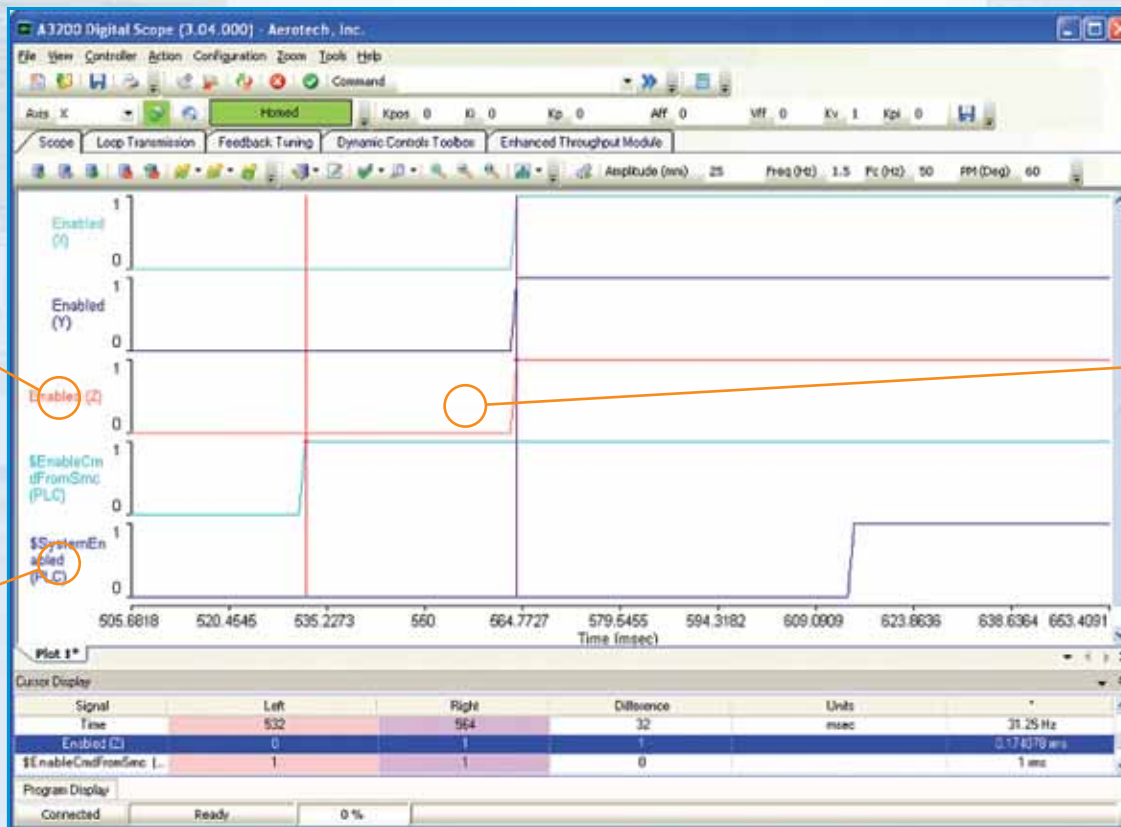

All information in Global Tag database available for real time plotting and analysis with all motion variables

SDK: Software Development Kit

- Easy to use
- Faster development
- Lower maintenance cost

Use the Aerotech standard GUI...
...or build a custom interface
for your application

- C#
- VB.NET®
- Managed C++
- LabVIEW® (VIs provided)
- C Library
- EPICS

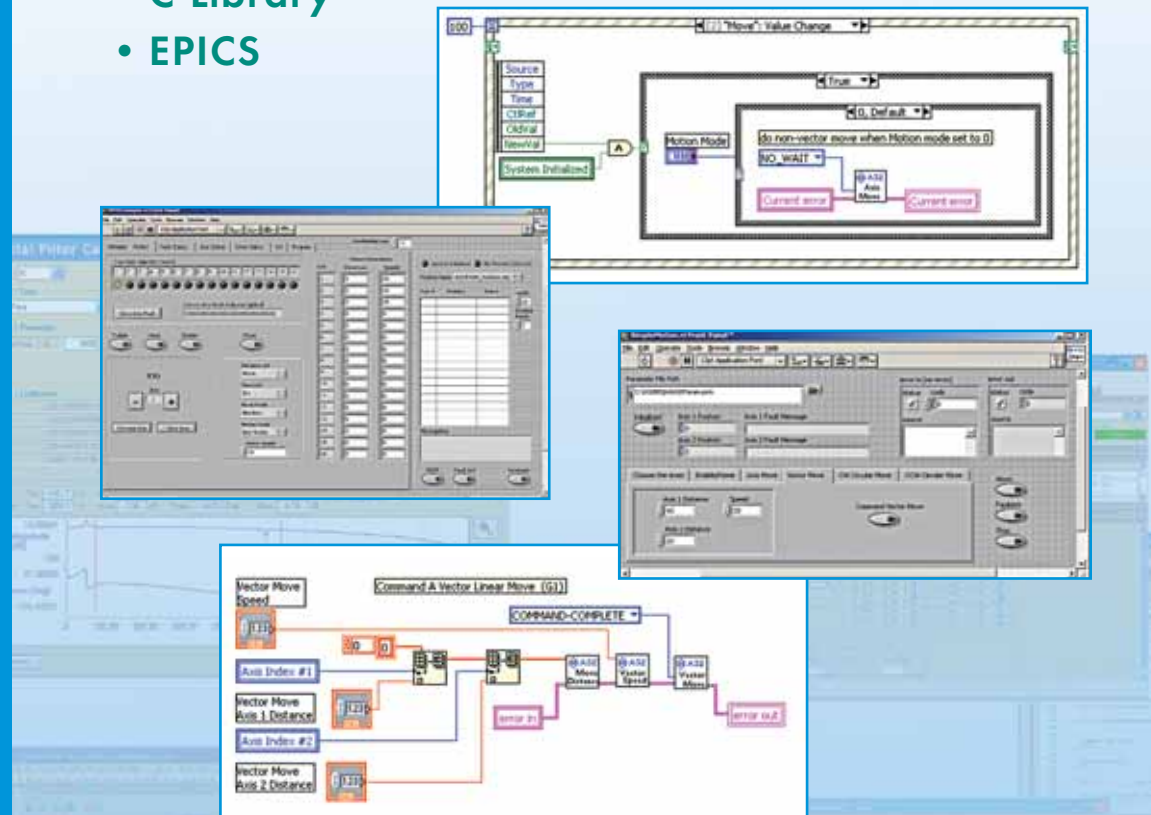

.NET Library

- High-end motion with a custom GUI
- Use the best language for the application
- Fully functional libraries for each language

All Aerotech applications are written using the .NET library. Aerotech provides customers with the same tools used at Aerotech.

Take Advantage of:

- **.NET Framework 2.0**

- Generics
- Enumerations
- Indexers
- Events
- Exceptions

- **Object Model**

- Well-organized structure with two main classes: network and controllers
- Common features are higher in the hierarchy
- Minimal code required to accomplish the task at hand

- **Libraries Include:**

- Initialization functions
- Global data functions
- Motion functions
- Error handling
- Status and position functions
- Analog and digital I/O functions
- Parameter functions
- Run CNC program functions
- Utility functions
- Get and set variable functions

Object Model

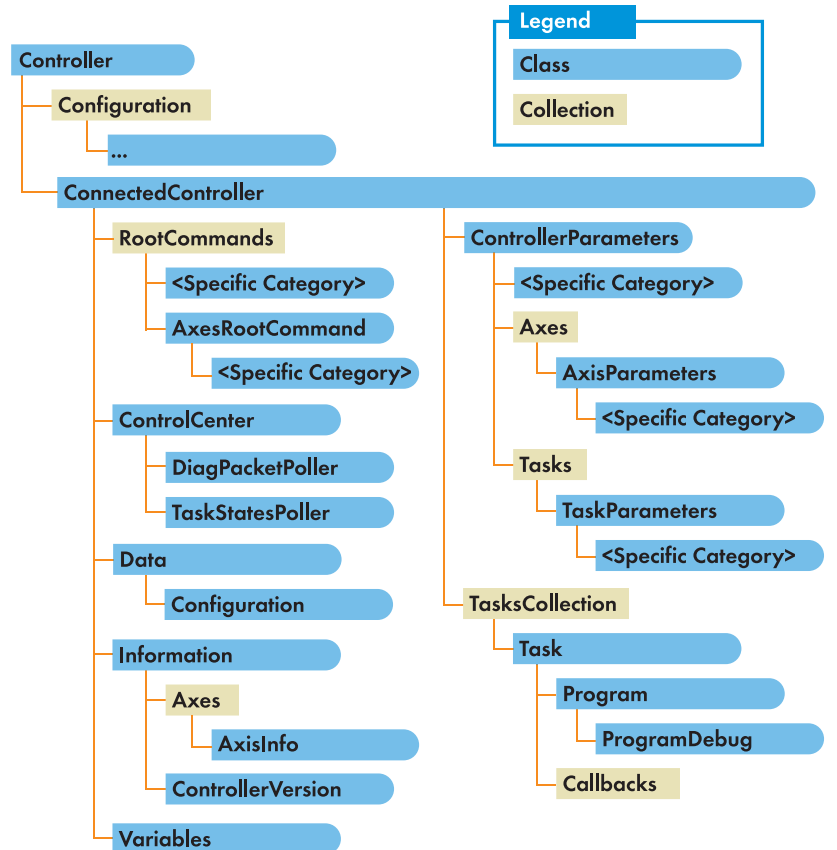

Motion Designer:

Graphical Trajectory Generation and Data Analysis

Create and modify multi-axis trajectories using predefined building blocks to provide rapid motion prototyping

Perform data analysis such as FFT, max, min, average, rms and standard deviation from an existing trajectory for diagnosing system performance

Add standard filter types: notch, resonant, low pass and high pass

Enter standard filter frequency parameters

Digital filter coefficients are automatically calculated

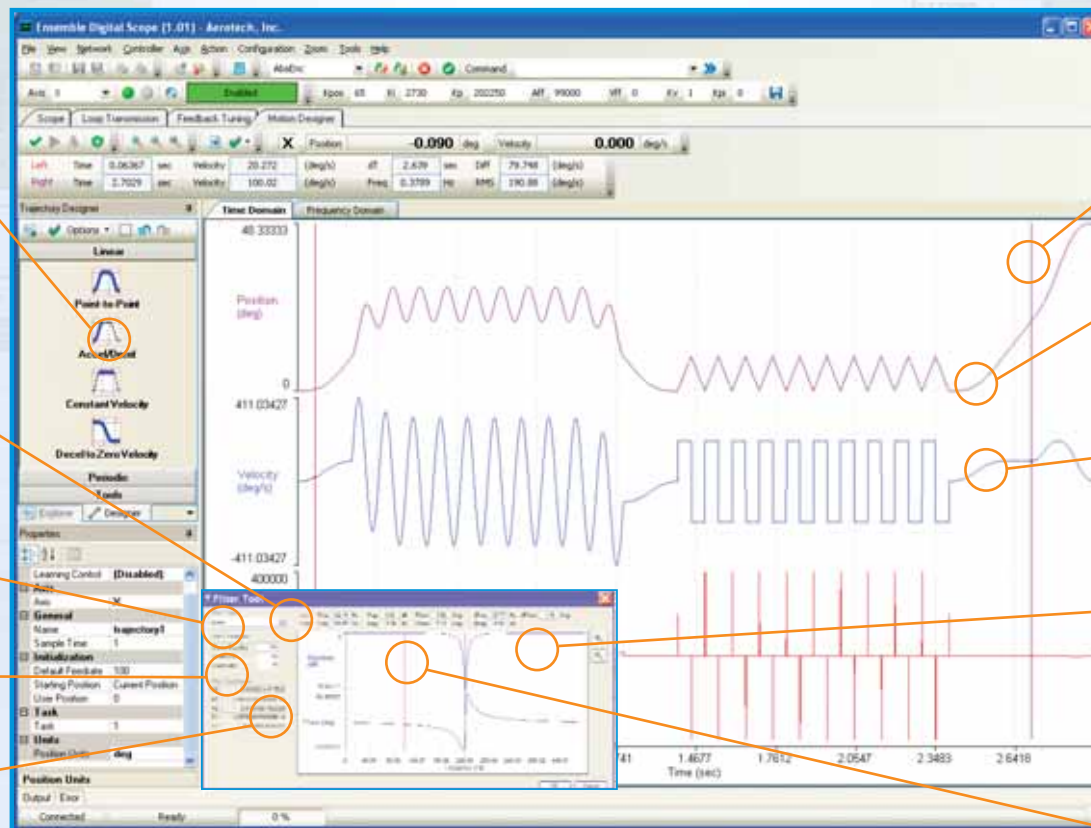

Cursor control

Apply filters to shape the trajectory frequency content

Import existing position, velocity or acceleration data

View the composite filter before applying to the trajectory

Cursor control

- Minimize programming time
- Import actual data
- Import from Excel or MATLAB®

Applications

- Dynamic environment simulation
- Sensor or component testing
- Gyros or accelerometers; tracking or beam-steering gimbals
- Crash sensors and roll-over sensors

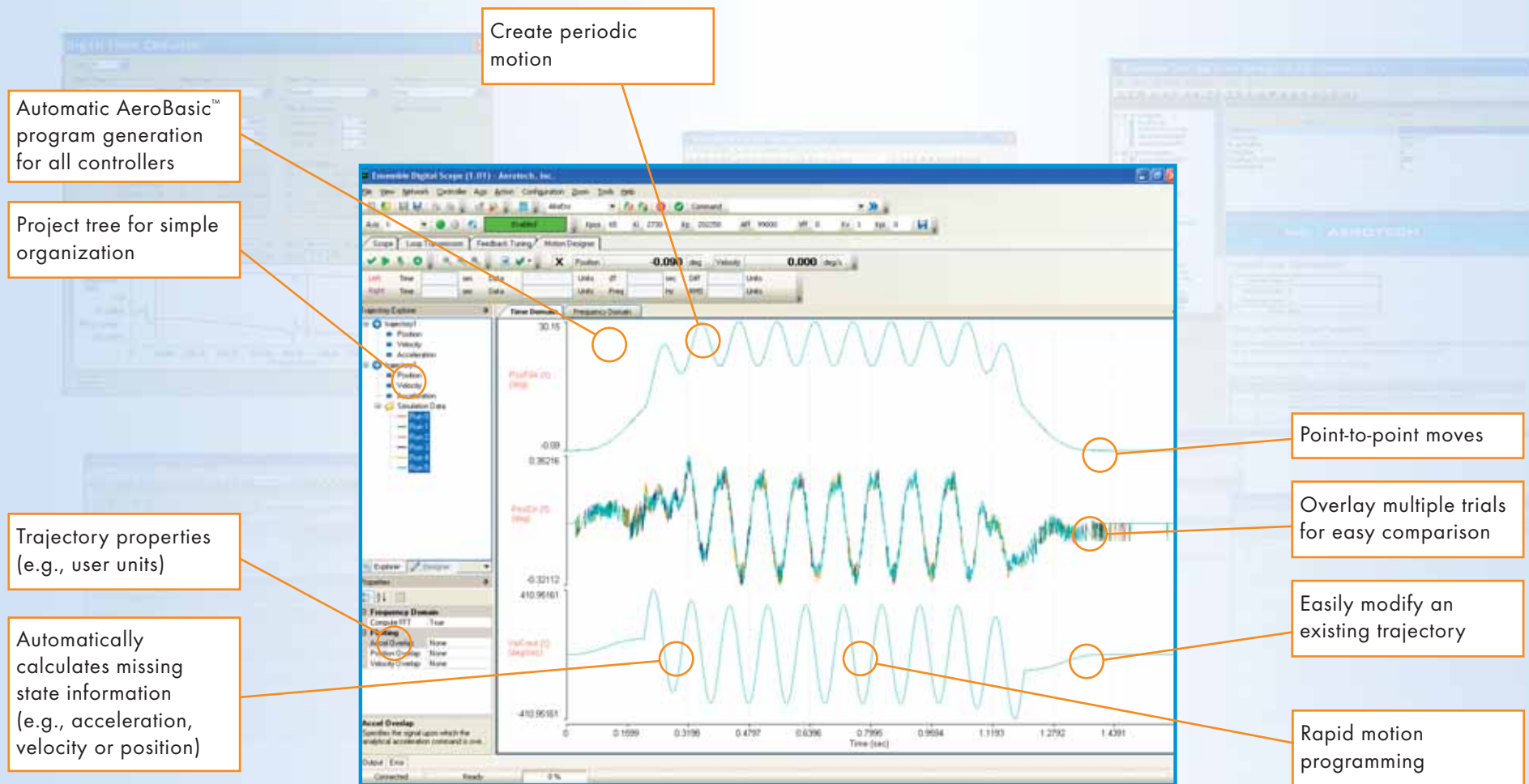

Motion Simulator – GUI

- Operate 1,2,3 axis motion simulators
- Frequency response mode allows input sine sweep and UUT performance tests on customer device
- Harmonic Cancellation optimizes motion position errors generated by sinusoidal motion

Aerotech Motion Simulator – The Integrated, Easy to Use, Graphical Trajectory Generation, Data Analysis and Enhanced Machine Performance Toolkit.

Aerotech's Motion Simulator software is an easy-to-use Windows®-based program for creating simple and advanced motion stimuli for testing and calibrating inertial sensors and systems. The Aerotech Motion Simulator software includes all controls for manually or automatically running 1-3 axis motion simulations. The GUI provides a user interface and programming environment that requires no third-party development software.

Key Features:

- User-friendly Windows®-based graphical user interface
- Trajectory tracking from Ethernet, analog or Windows® program inputs
- Iterative Learning minimizes position error
- Overlap multiple runs of a trajectory to easily see how program changes modify the motion
- Perform data analysis such as FFT, max, min, average, rms and standard deviation from an existing trajectory for diagnosing system performance
- Data input file formats include Excel, CSV or MATLAB®; Motion Simulator can calculate the missing state variables



Main Screen

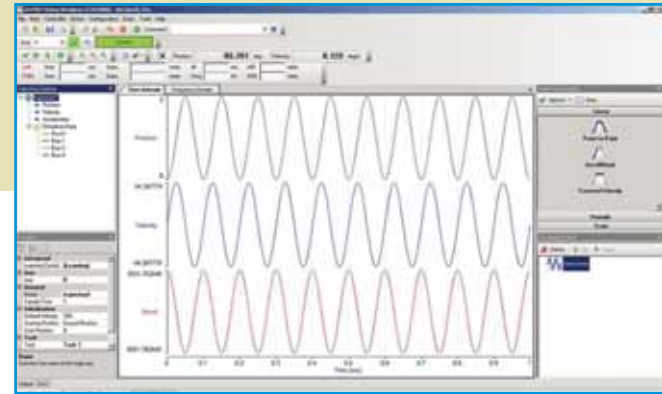

Motion Designer

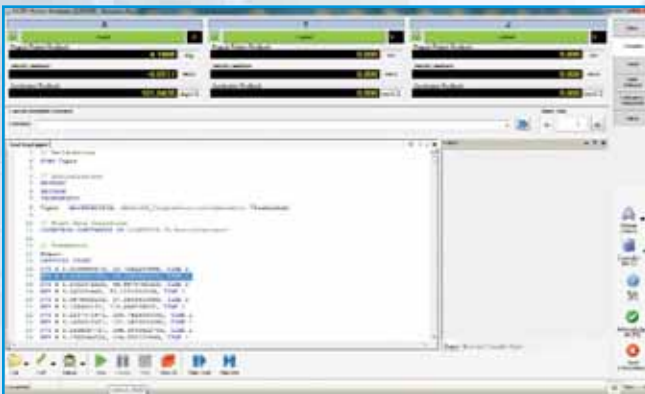

Program

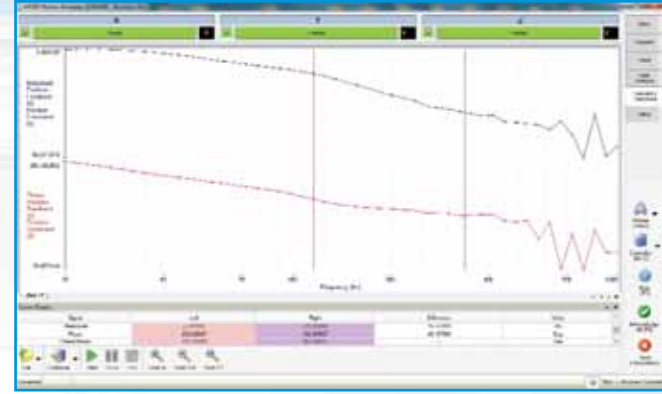

Frequency Response

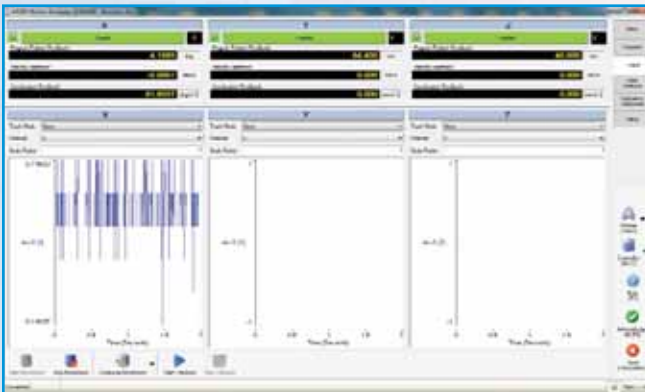

Track screen allows external signal selection for tracking

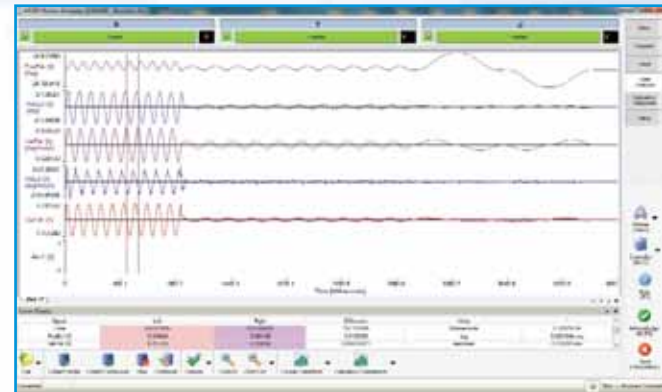

Data Analysis

Operator Interface

- Use the Aerotech Operator Interface (OI) for fast deployment
- Customize the OI to suit the application
- User customizable buttons that can execute standard G-code and AeroBasic™
- Quickly build a new interface in the OI builder*
- Import and export to Visual Studio® for flexibility*

Configurable Operator Interface

The screenshot displays the Aerotech CNC Operator Interface (OI) software. It features several key components:

- Issue immediate commands:** A panel at the top left with buttons for X, Y, Z, U, and A axes.
- Configurable axis manager:** A central panel showing axis status (Homed, Disabled) and velocity feedback (VH, V).
- Configurable jog pad:** A panel on the right with directional buttons for jogging and velocity settings (Low, High, Distance, Hold).
- User customizable buttons:** A panel on the far right with buttons for Home X, Home Y, Home Z, and Home U, each with a custom G-code program assigned.
- Active program:** A text area at the bottom left showing the current G-code program being executed.
- Standard machine controls:** A panel at the bottom with buttons for Open, Run, Stop, Feedhold, and Abort.
- Designed for touch screen:** The interface is designed for touch screen operation, with large, clear buttons.
- Set up simple or complex action – user can attach a standard G-code program to a button:** The Home buttons on the right allow users to attach custom G-code programs to specific machine actions.

Advanced Software Architecture

- Layered for flexibility
- Customizable at many layers
- Most cost-effective solution

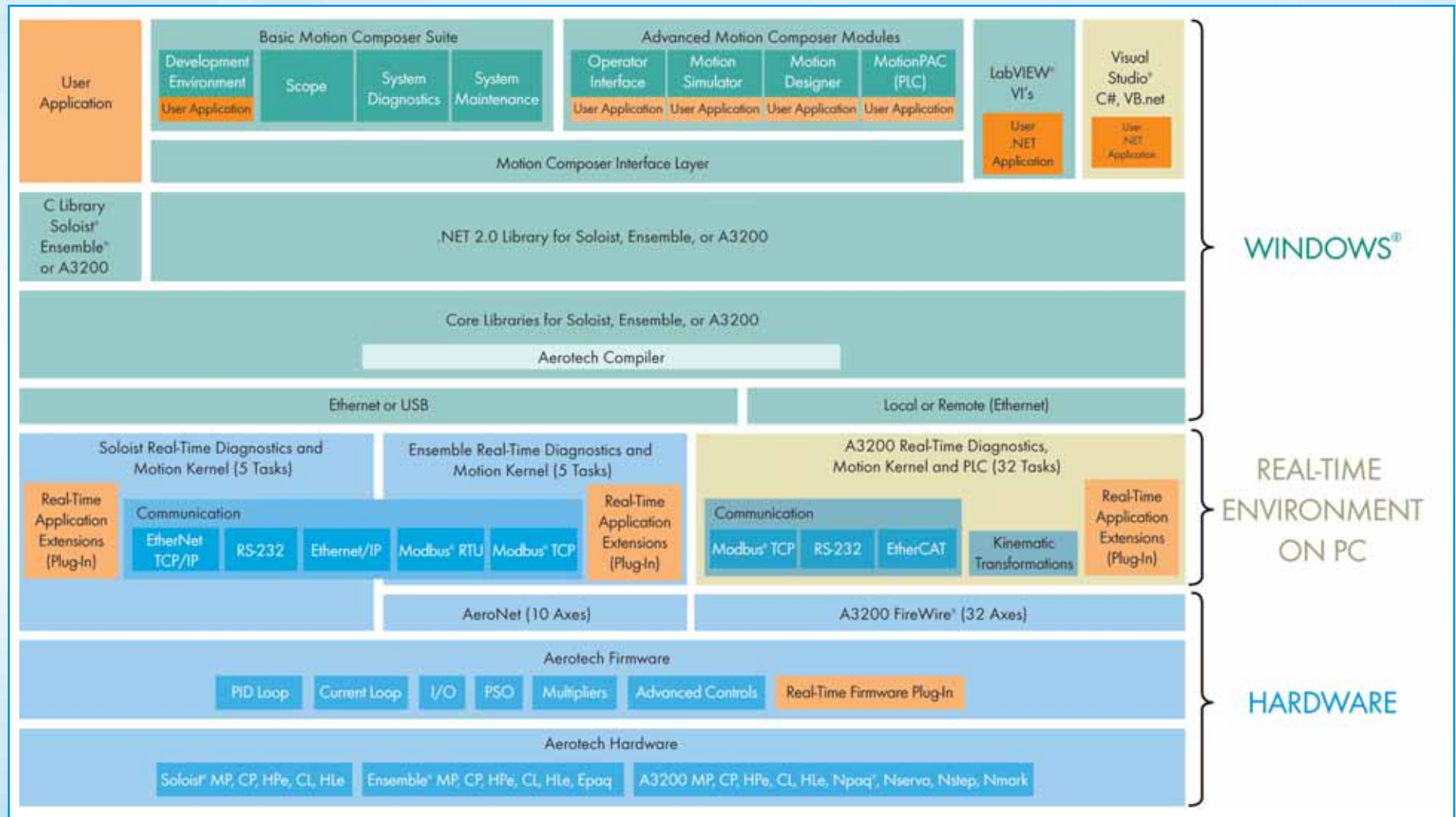



Digital Automation Platform

- Higher throughput due to high performance control, network and high-power drives
- Higher accuracy and repeatability due to all digital drives and advanced servo algorithms
- Faster startup and changeover results from fully integrated motion platform, easy-to-use setup tools and extensive diagnostics
- Lower startup and life-cycle cost due to less components and reduced engineering
- Higher reliability due to fewer components
- Simplified integration

Distributed Motion Control

- Motion trajectory generation and synchronization are centralized at the PC
- Motion execution is decentralized at the drives
- A3200 operates on any standard desktop or industrial PC
- Servo loops are closed on the drive

Use Nservo to Retrofit Existing Motors & Drives or Drive Large Motors

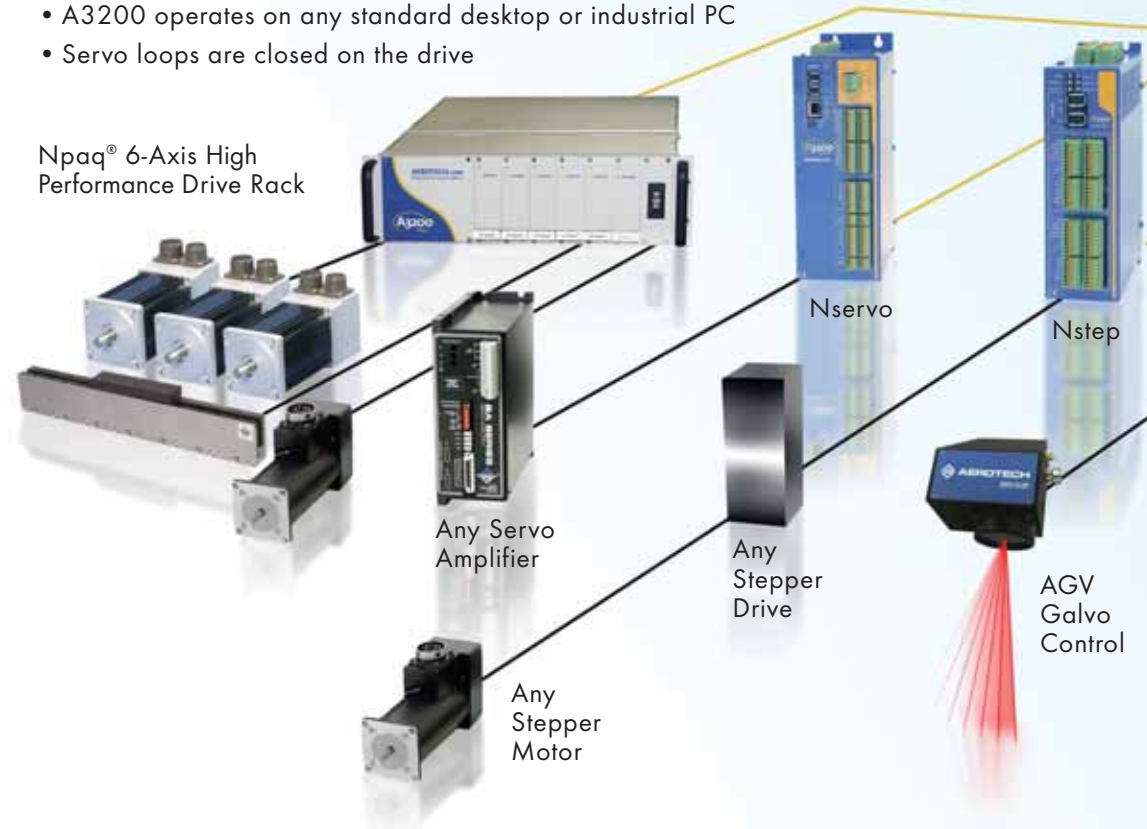

Remote Server Option

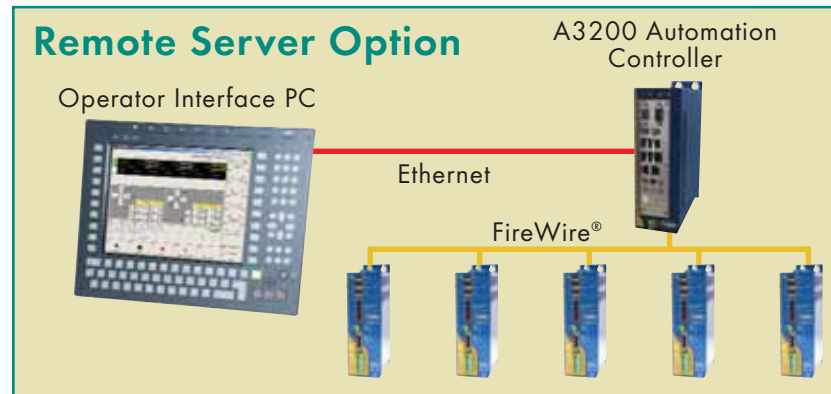

The Intelligent 32-Axis Motion, Vision, PLC, Robotics and I/O Platform

- Easily installed digital drives
- FireWire® (IEEE-1394) industry standard, high-performance motion bus



FireWire®

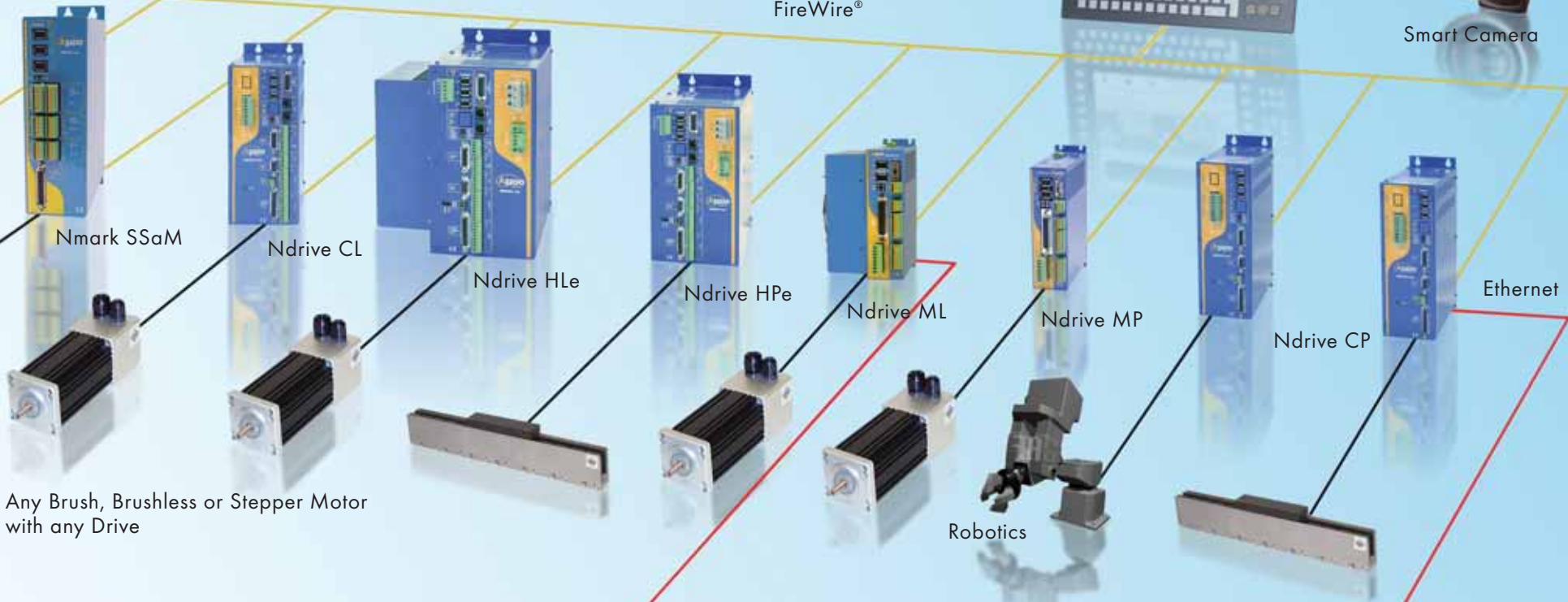

Any Brush, Brushless or Stepper Motor with any Drive

Digital Drive Features

- PWM or linear (10 A to 150 A peak)
- Integrated 10/100 Base-T Ethernet
- Encoder, resolver or inductosyn feedback
- Onboard x65536 encoder multiplication
- 20 kHz position, velocity and current-loop sample rate
- Integral power supply
- Sinusoidal commutation
- Local I/O ports



Easily integrates with Keyence LK-G Series Laser Displacement Sensors



Ethernet I/O Expansion
Analog and Discrete I/O

Ensemble[®]

Stand-Alone Multi-Axis Automation Controller

- Easy to use
- Powerful architecture
- Distributed control
- Network ready

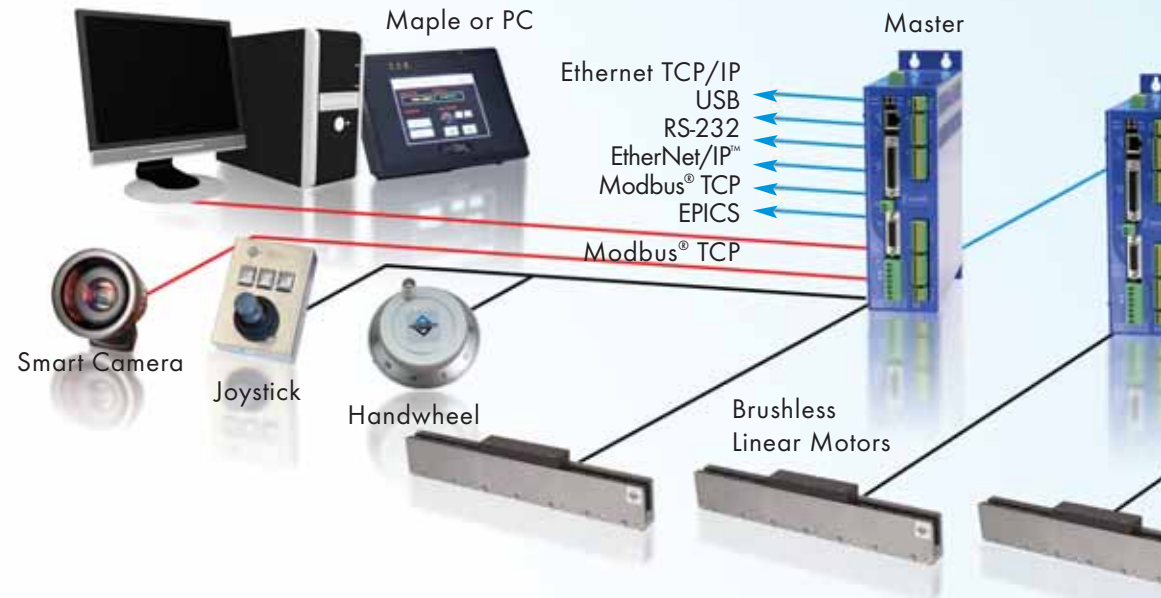

6-Axis Stand-Alone, Rack Mount or Desktop Plus Three Axes



Software, Controls, Drives and I/O... All in One Package

10-Axis, Stand-Alone, All Digital, Panel-Mount Controllers

AeroNet

from 10 to 150 A peak



Applications

- Semiconductor
- Medical
- Test and Inspection
- Packaging

Capability

- Point-to-Point
- Linear and Circular Interpolation
- Electronic Gearing
- Velocity Profiling
- Gantry

Soloist[®]

Stand-Alone Single-Axis Automation Controller

- Easy to use
- Scalable
- Ethernet/USB connectivity

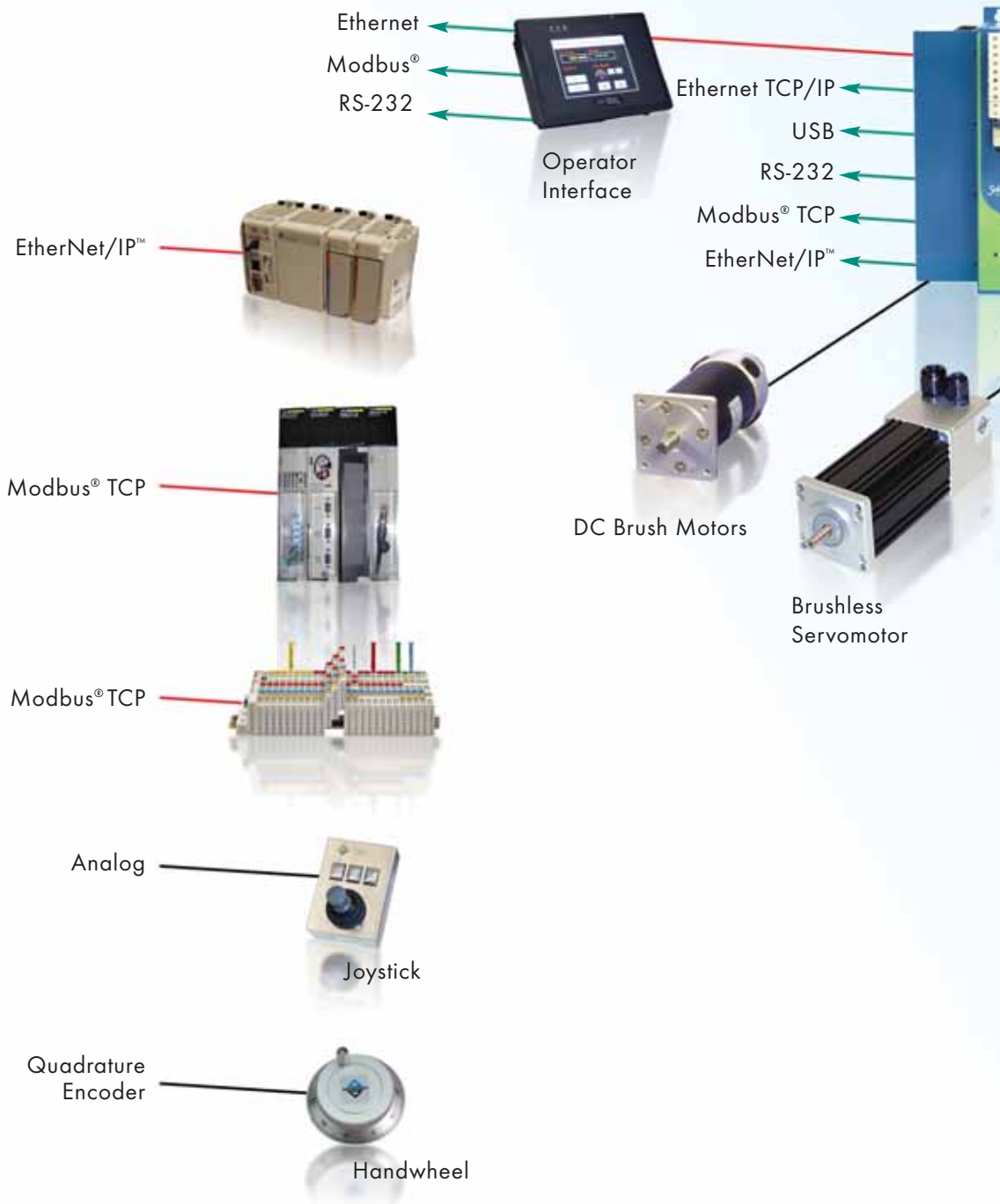

Software, Controls, Drives and I/O in One Compact Package

from 10 to 150 A peak

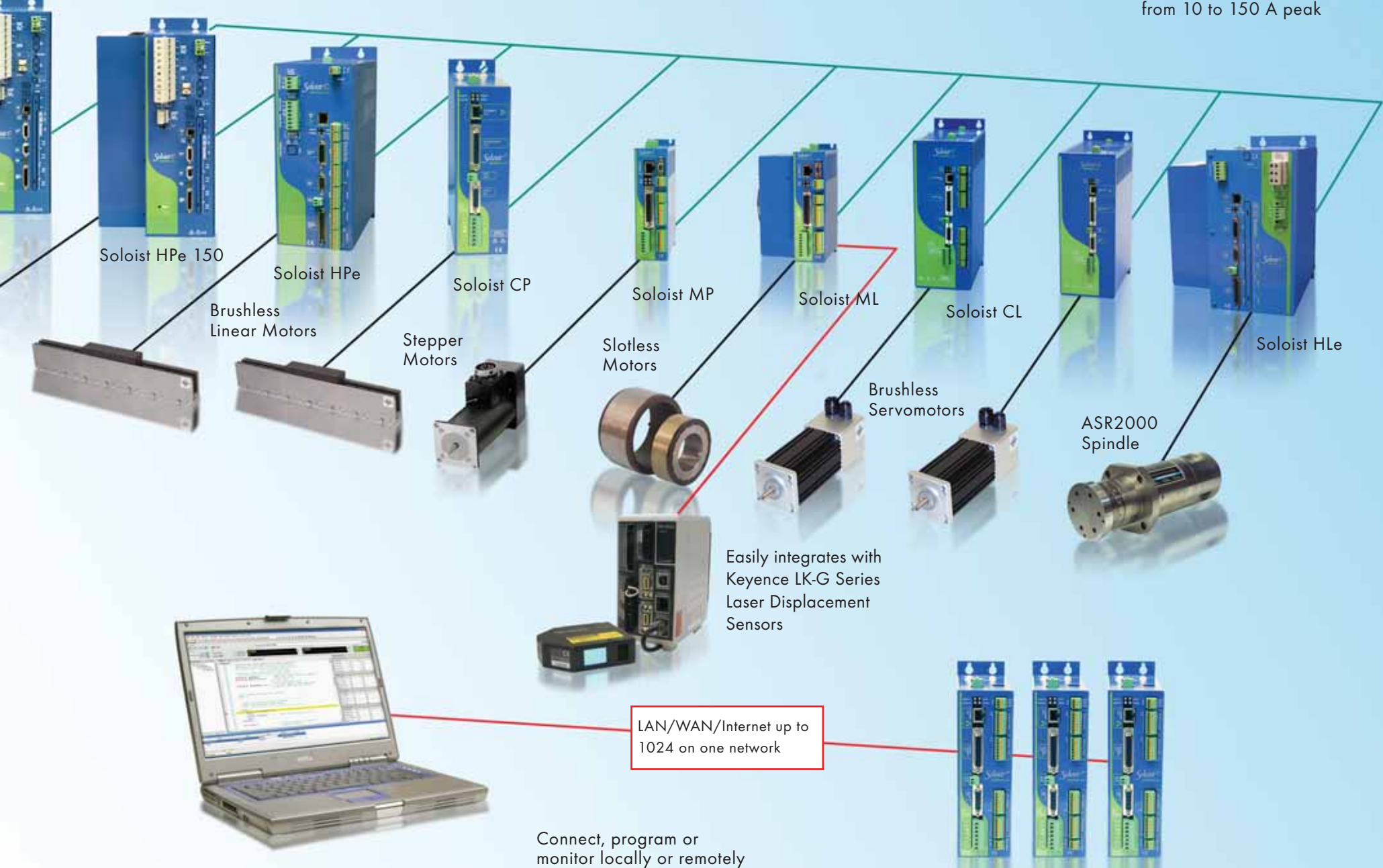

Controller and Drive Technology

Ndrive® MP Ensemble® MP Soloist® MP

Width: 41.1 mm
Height: 141.2 mm

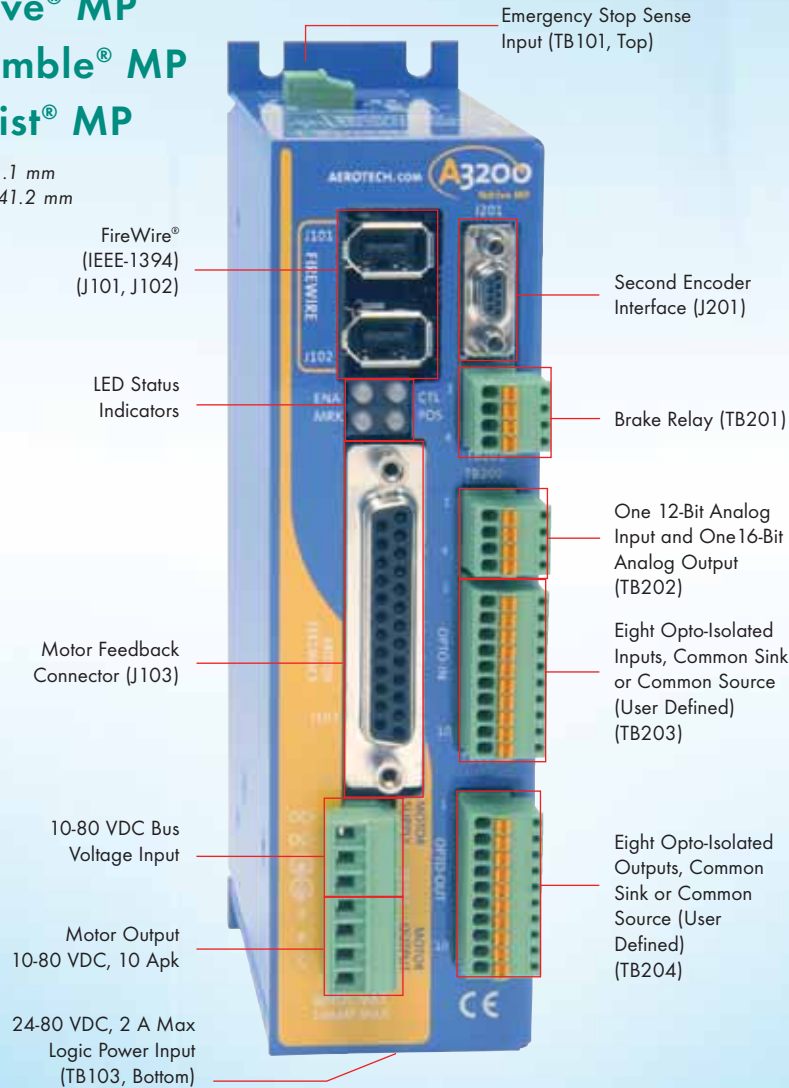

Ndrive® CP Ensemble® CP Soloist® CP

Width: 63.5 mm
Height: 198.2 mm

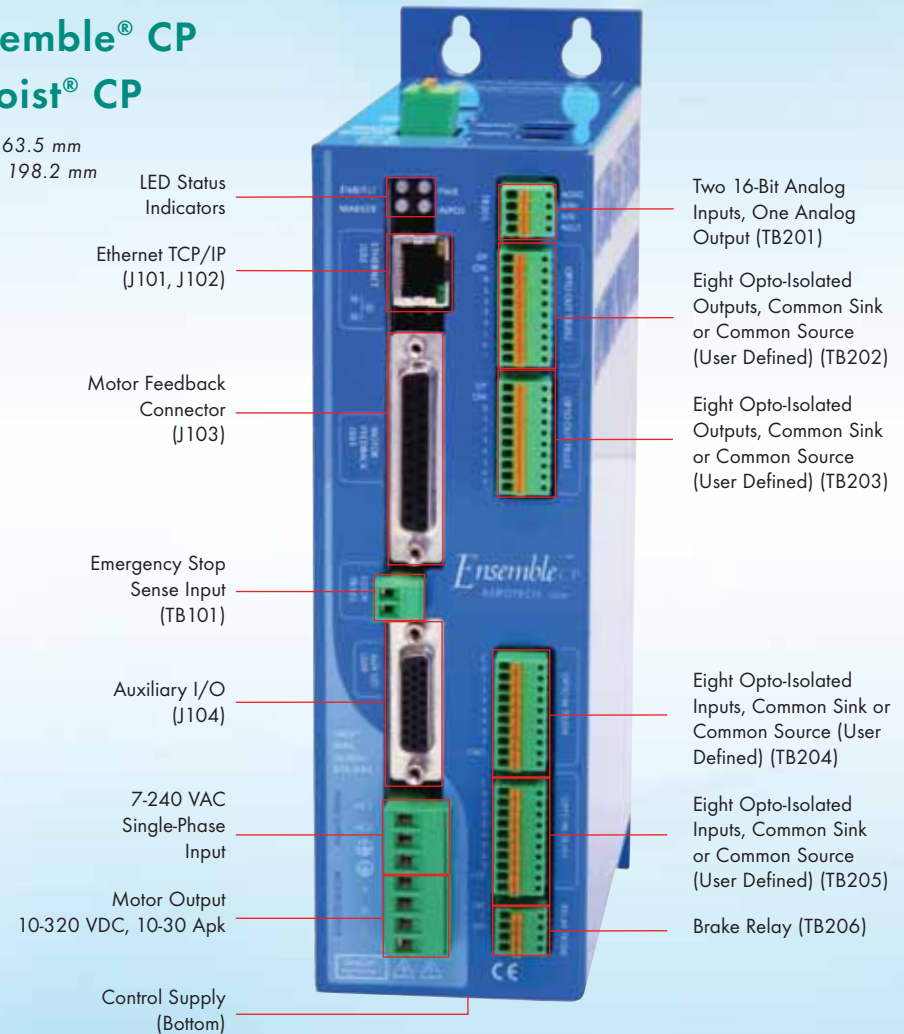

• MP for OEMs lowers costs

• CP solutions for less integration work

• HPe for the highest performance solution

Ndrive® HPe
Ensemble® HPe
Soloist® HPe

Width: 99.1 mm
Height: 232.5 mm

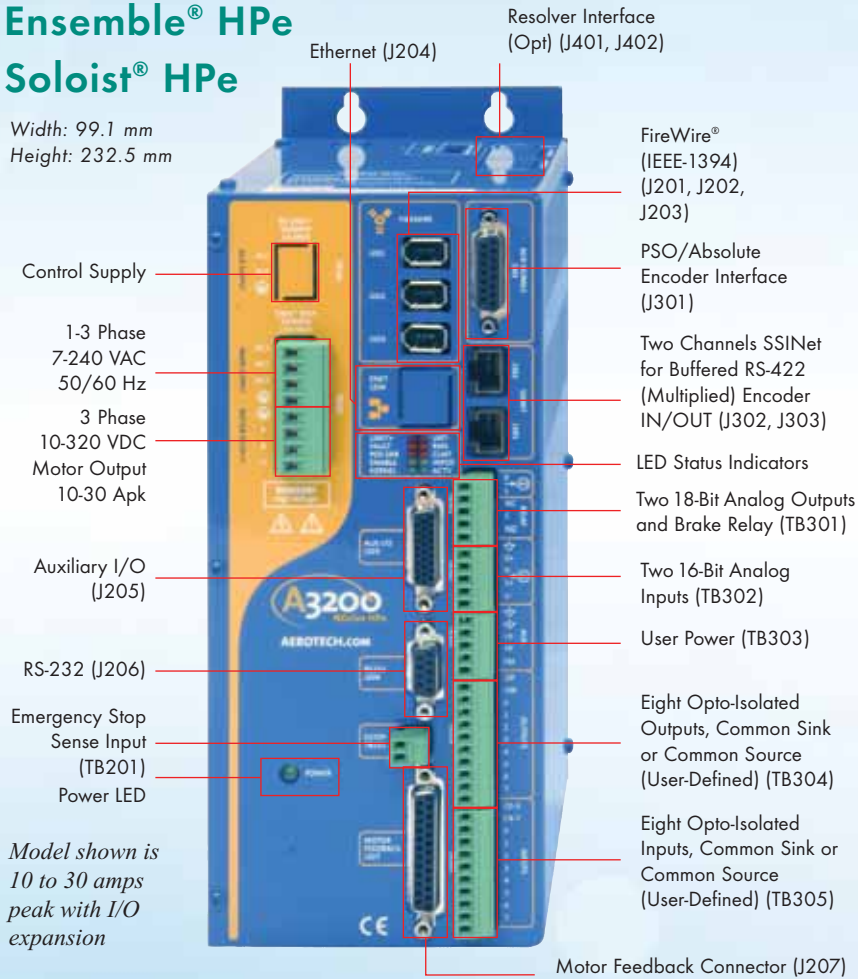

Model shown is 10 to 30 amps peak with I/O expansion

Ndrive® HPe
Ensemble® HPe
Soloist® HPe

Width: 212.6 mm
Height: 234.8 mm

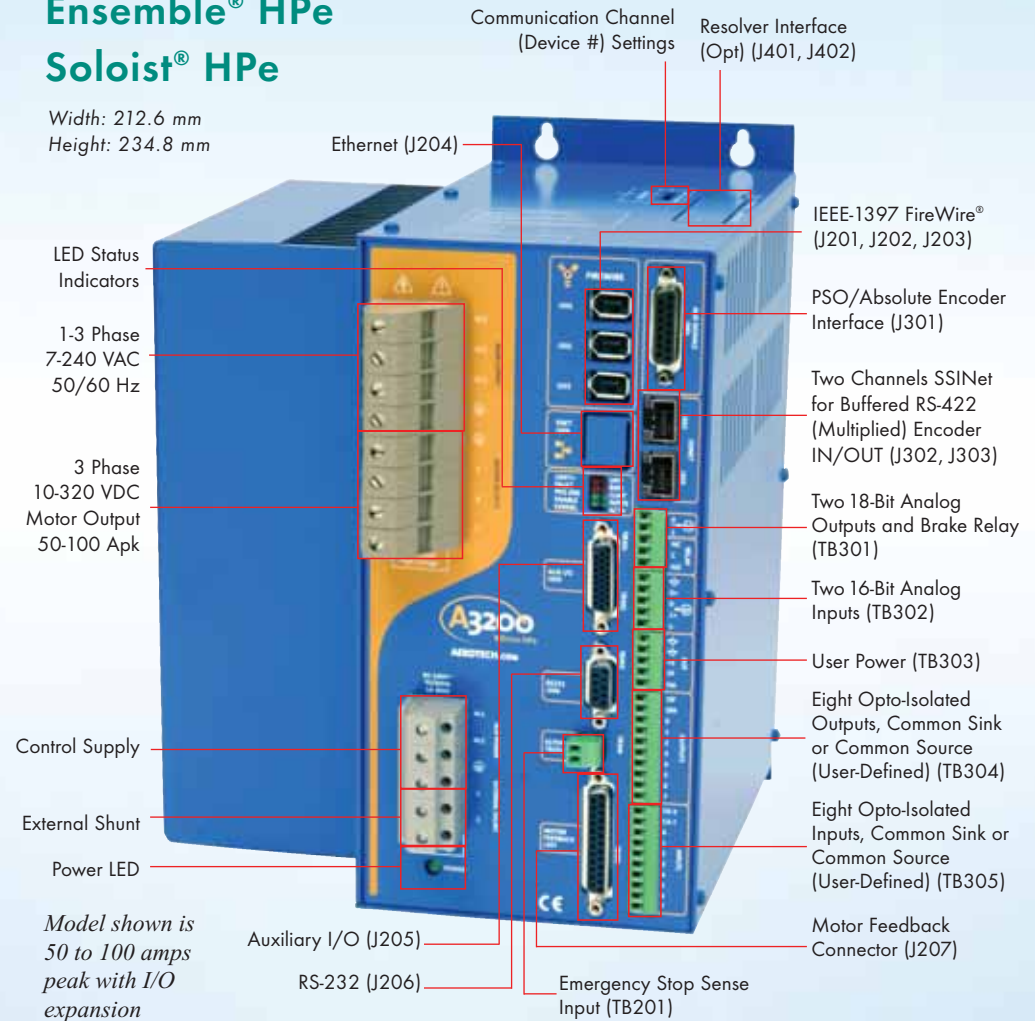

Model shown is 50 to 100 amps peak with I/O expansion

Controller and Drive Technology

Ndrive® HPe150 Ensemble® HPe150 Soloist® HPe150

Width: 229.7 mm
Height: 406.1 mm

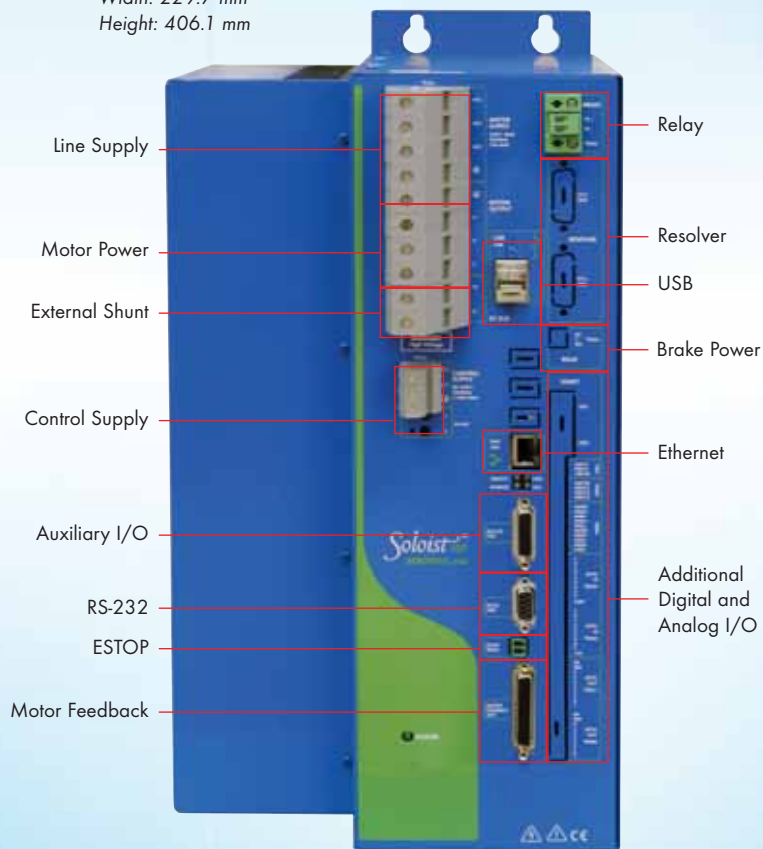

Ndrive® ML Ensemble® ML Soloist® ML

Width: 41.1 mm
Height: 141.2 mm

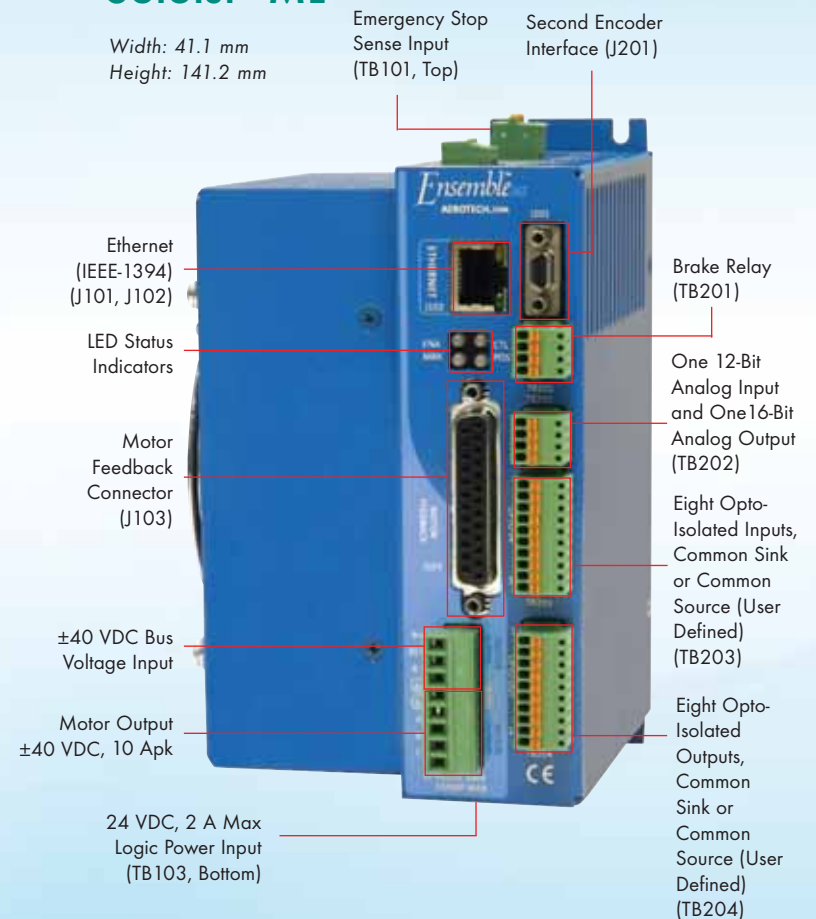

Linear Drive Advantages

- Ultra-smooth motion during reversals
- Superior in-position stability
- Integrated with controls
- No switching noise
- No dead band
- Low EMI

Applications

- Nondestructive testing
- Stencil cutting
- Any small move, or sinusoidal movements
- Very slow velocity applications
- Stent manufacturing
- Target tracking
- Piezo stages

Ndrive® CL Ensemble® CL Soloist® CL

Width: 103.7 mm
Height: 265.2 mm

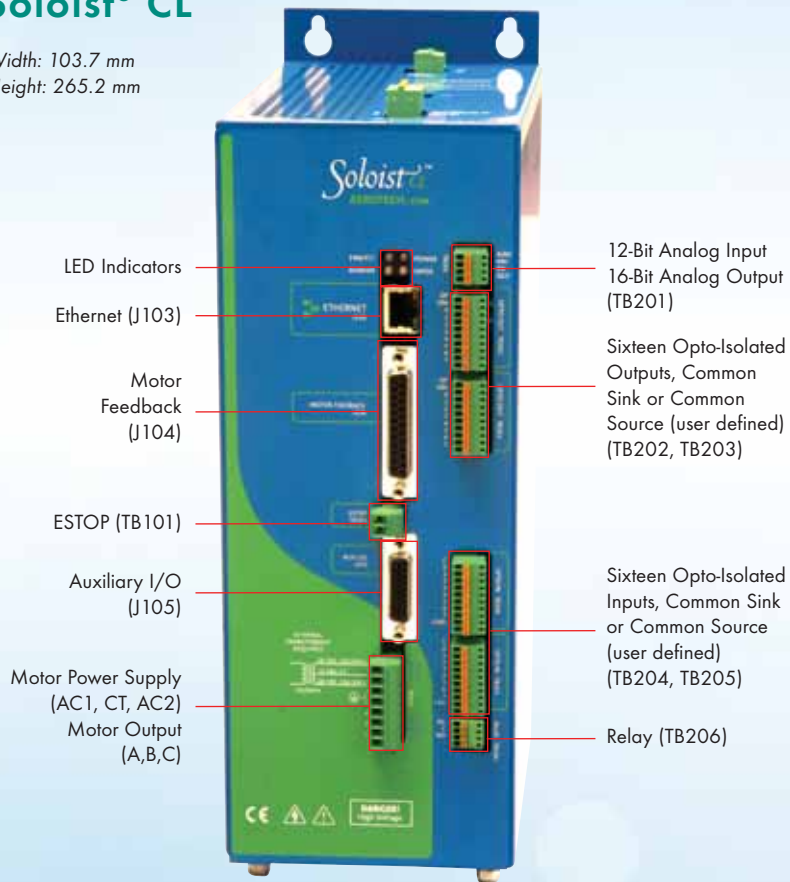

Ndrive® HLe Ensemble® HLe Soloist® HLe

Width: 206.9 mm
Height: 234.3 mm

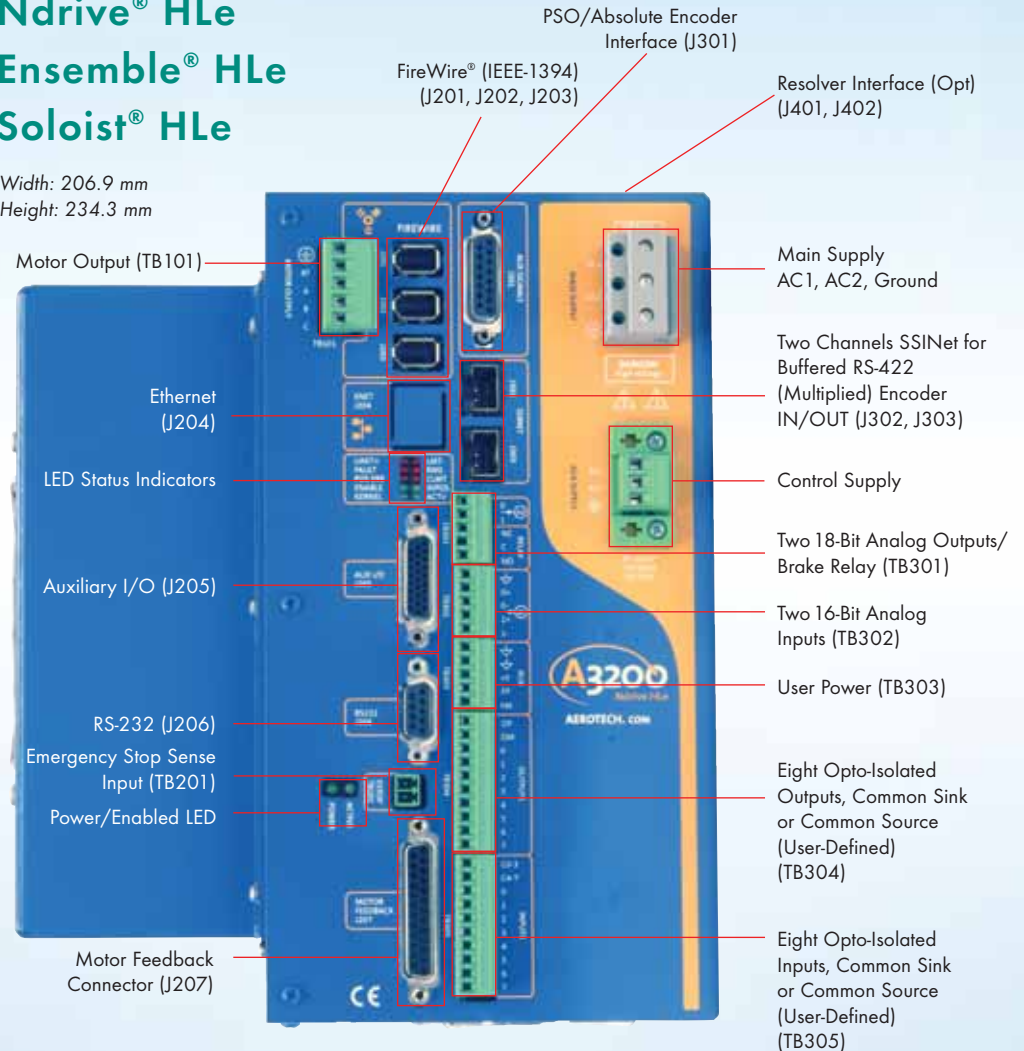

Controller and Drive Technology

Nmark™ CLS

Width: 90.5 mm
Height: 210.8 mm



Nstep

Width: 49.2 mm
Height: 161.8 mm

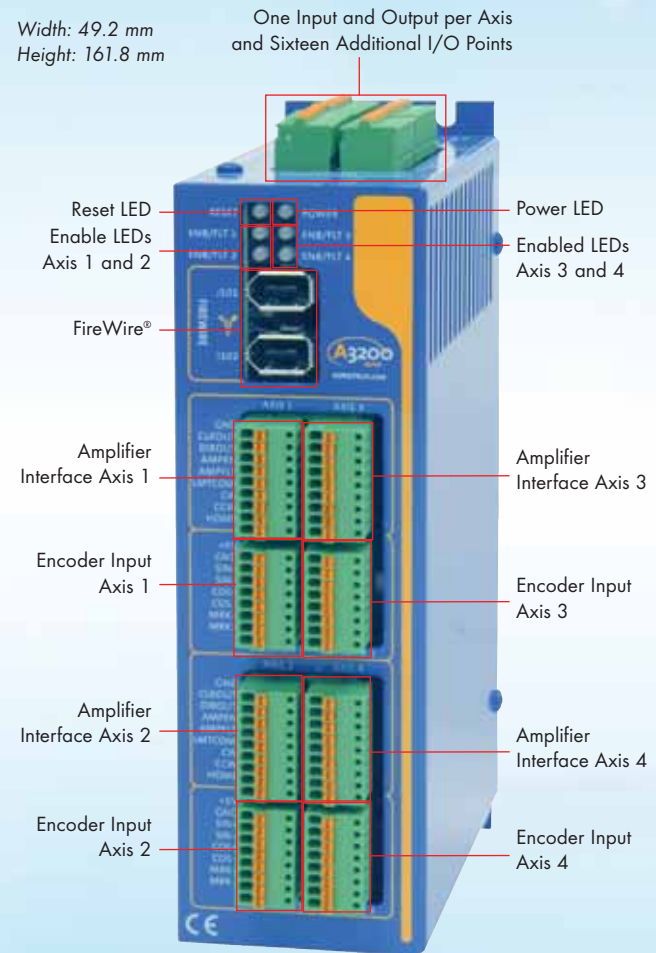

Nservo

Width: 87.6 mm
Height: 230.4 mm

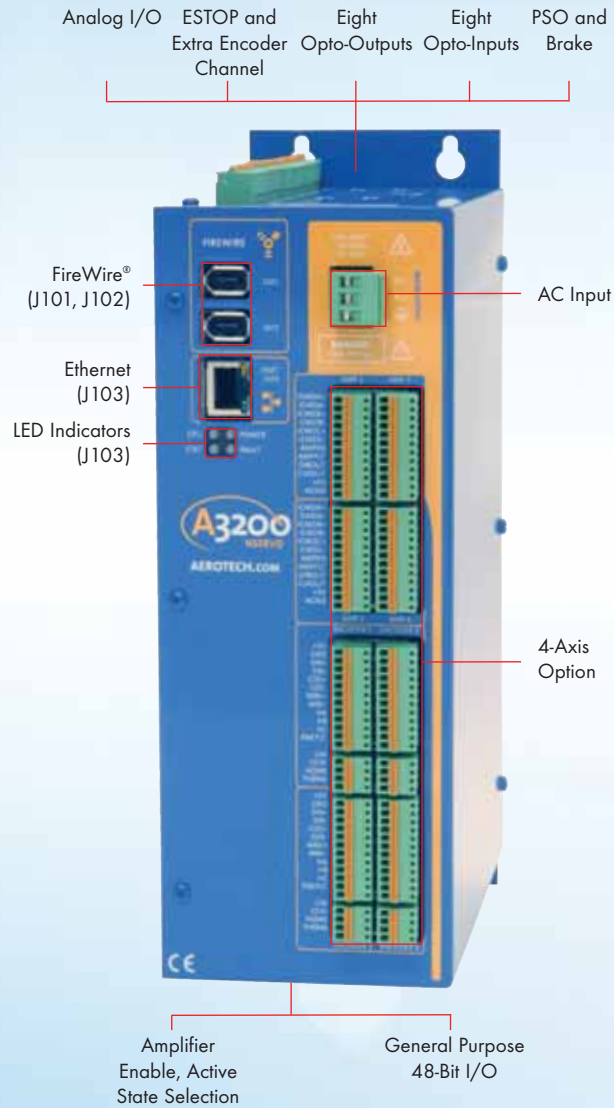

Nservo - OEM

4 Axis or Less
Width: 284.5 mm
Height: 276.9 mm

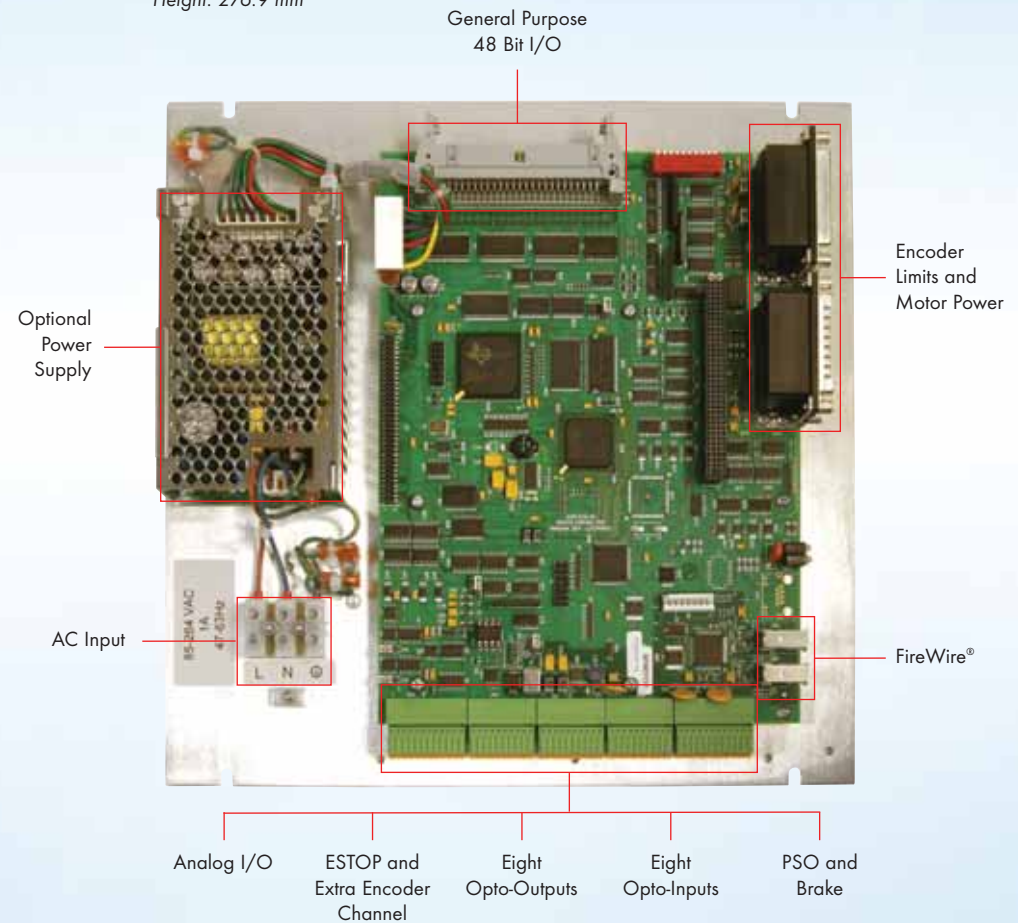

Controller and Drive Technology

Console



Npaq®

6 Axis or Less
Width: 436.7 mm
Height: 132.0 mm



Laser Feedback (Optional)
Power Switch/Circuit Breaker

Npaq® MR/Epaq MR

8 Axis or Less
Width: 436.7 mm
Height: 132.0 mm

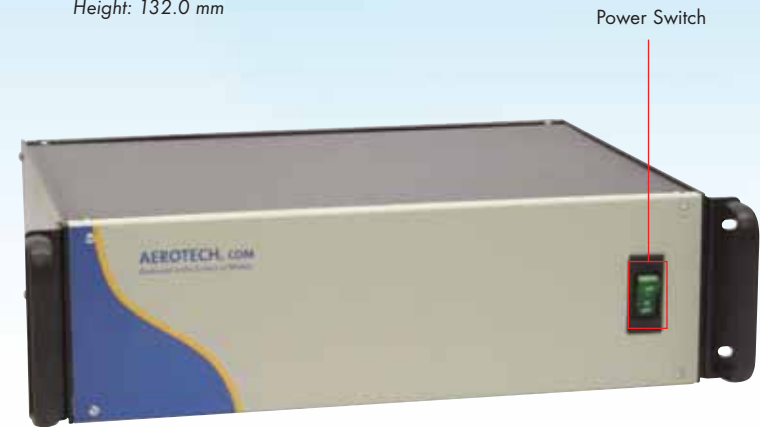

Power Switch

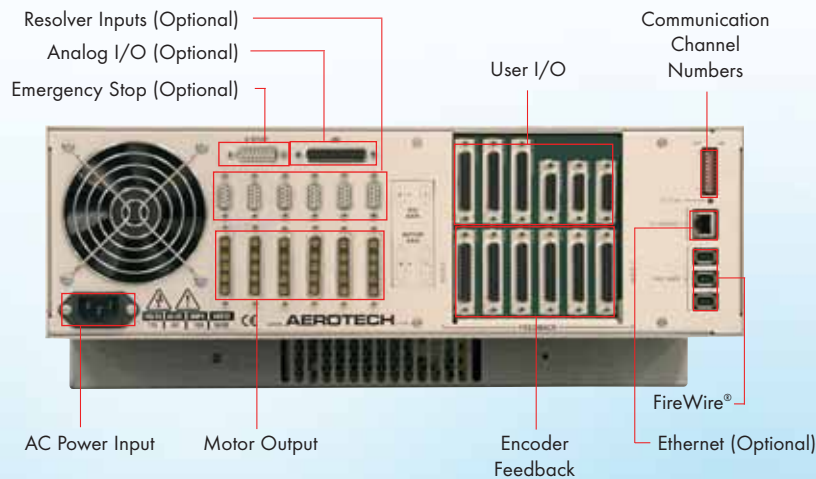

Resolver Inputs (Optional)
Analog I/O (Optional)
Emergency Stop (Optional)
AC Power Input
Motor Output
Encoder Feedback
User I/O
Communication Channel Numbers
FireWire®
Ethernet (Optional)

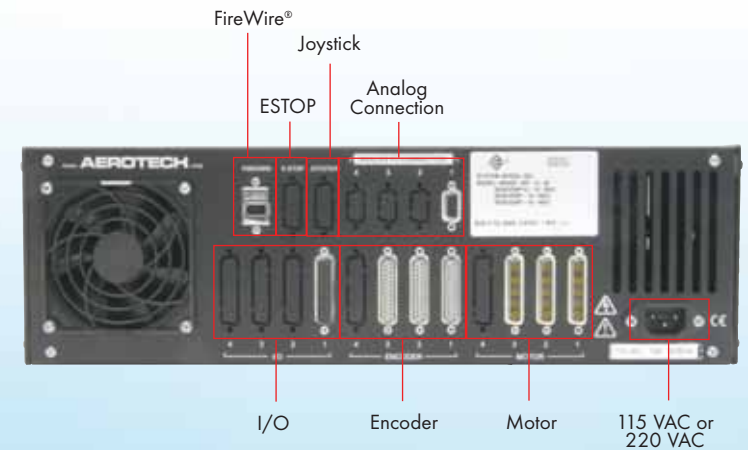

FireWire®
Joystick
ESTOP
Analog Connection
I/O
Encoder
Motor
115 VAC or 220 VAC

Npaq[®] and Epaq Rack Mount or Desktop Solutions in One Box Minimize Wiring

Ensemble[®] Epaq

5 Axis or Less
Width: 431.8 mm
Height: 177.8 mm

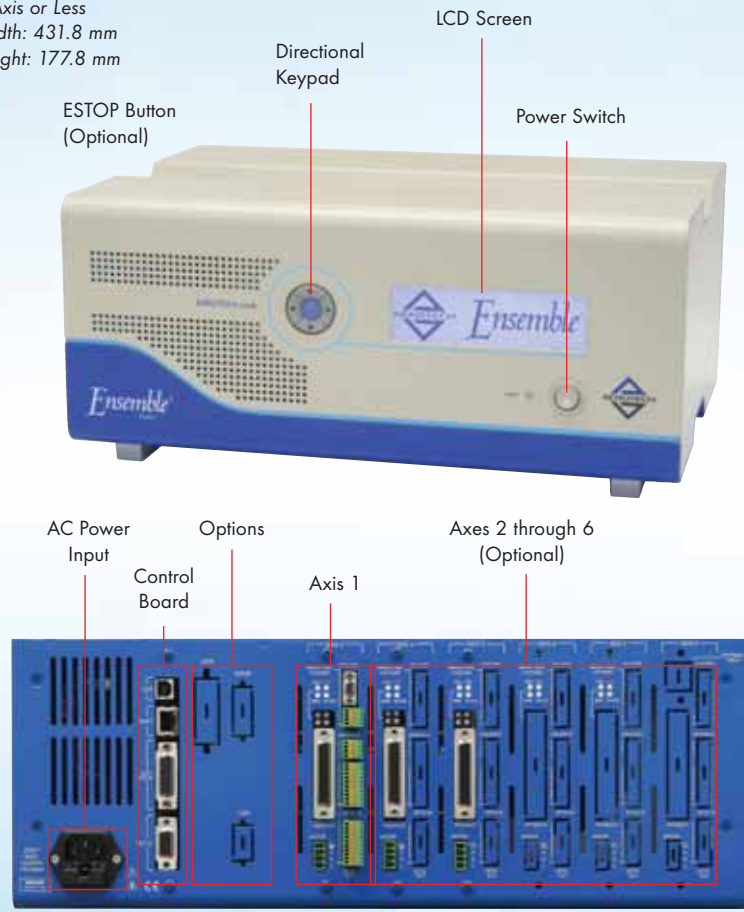

Ensemble[®] LAB

4 Axis or Less
Width: 370.2 mm
Height: 98.4 mm

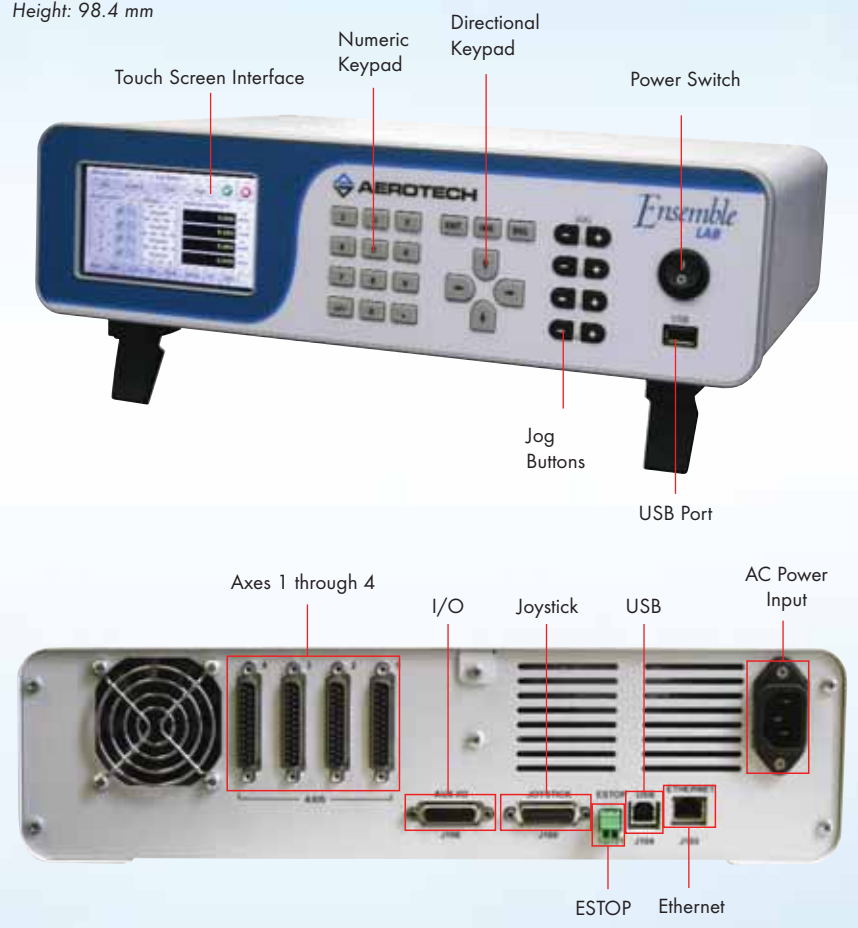

Standard Control Capabilities

Point-to-Point Motion

Basic independent axis positioning with programmable accel/decel and feedrate.

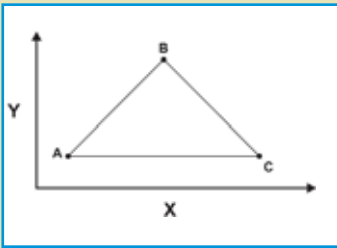

Acceleration Limiting

Anticipate sharp corners and small radius arcs and automatically decelerate as needed.

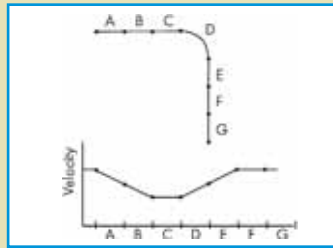

Coordinated Motion

Linear and circular motions are supported in all languages.

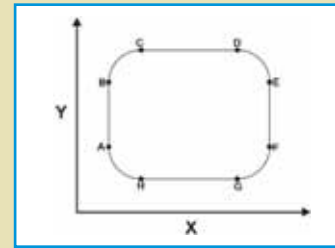

Arbitrary Path Generation (PVT)

Specify discrete position, velocity and time and the controller will interpolate to create a smooth, contiguous path.

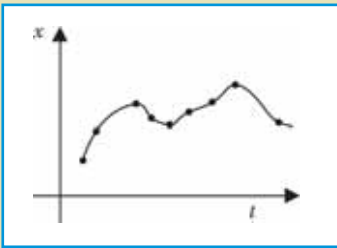

Electronic Gearing

Electronically control one axis as a simple ratio or as a complex function of another axis; fire I/O in real time during a move.

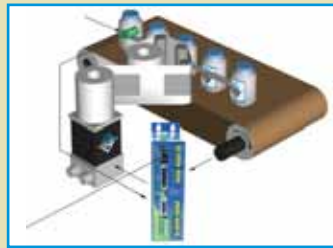

On the Fly End-Point Modification

Modify the endpoint during execution of the motion profile.

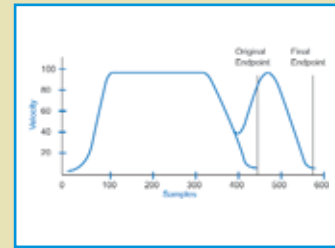

Cutter Compensation

Also known as tool radius compensation, this feature automatically adjusts the path to allow for the radius of a cutting tool.

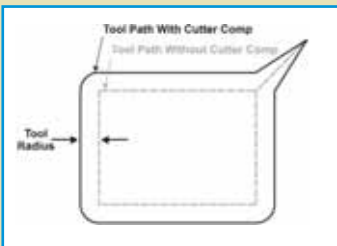

Parts Rotation

Use when a two-dimensional part must be repeated in different orientations without translating the part program many times over.



Velocity Profiling

Maintains a constant vector velocity along the programmed path.

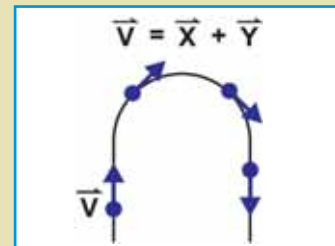

Aerotech controllers offer the broadest array of programming interfaces and core motion capabilities of any automation system available today. Aerotech controllers have the programming flexibility and capability to meet the requirements of the most demanding motion applications of OEMs and end-users alike.

Seven Segment Acceleration

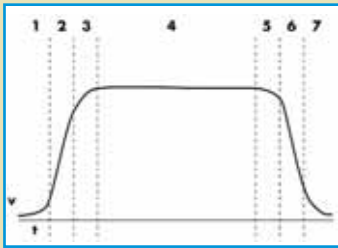

Specify the acceleration profile in seven segments, providing precise control over system motion.

Velocity Blending

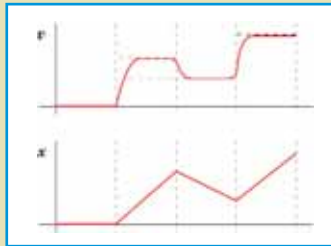

The velocity changes to the next velocity command, acceleration limited, without stopping.

Fast Position Capture

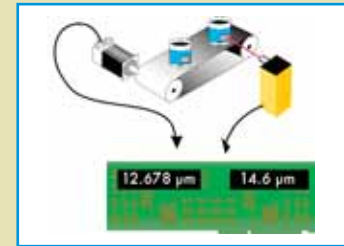

Store positions based on the transition of a digital input, allowing close correlation of axis positions to external events.

Retrace

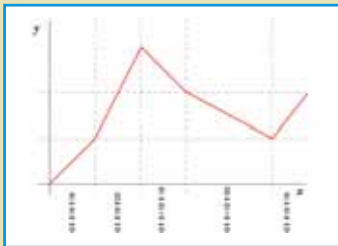

Retrace a path block by block.

Intra-Block Retrace

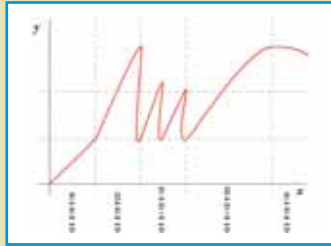

Retrace a path inside a block.

High-Speed Registration

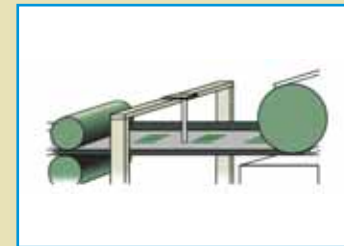

High-speed registration to trigger motion is useful in packaging and labeling.

Gantry Mode



Complex gantry control is reduced to a few simple commands to handle dual motor and/or dual feedback configurations.

Kinematics

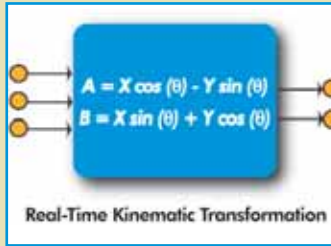

Execute complex inverse kinematic equations within the flow of the trajectory generation.

Analog Power Control



Adjust the setting of an analog output in relationship to the vector speed of two axes to permit the automatic regulation of laser power or material dispensing processes.

Standard Control Capabilities

Motor Control

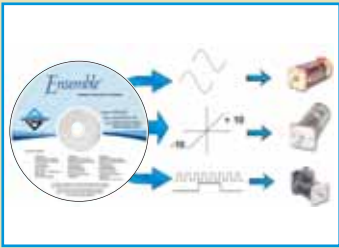

All controllers operate brush, brushless or stepper motors in any combination.

Orthogonality Correction

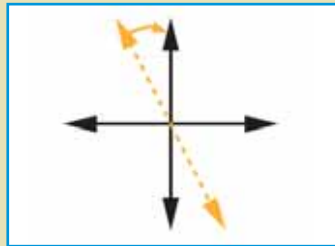

Improve X-Y planar accuracy by simply entering the known orthogonality error and the controller will compensate.

Axis Calibration

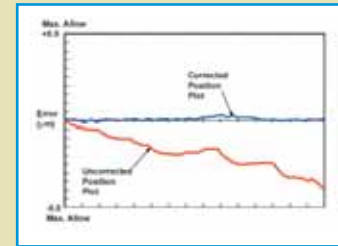

Compensate for repeatable mechanical errors in a positioning system.

Sinusoidal Commutation

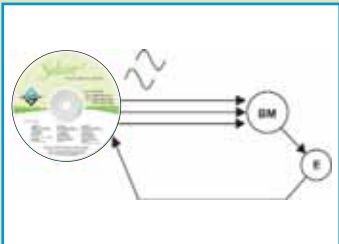

Brushless motors produce smoothest motion when sinusoidally commutated, eliminating the need for multiple transducers and reducing cabling.

3D Error Correction

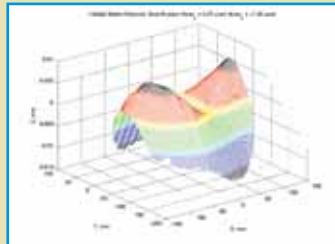

Measure XYZ errors and the controller can correct the commanded position to accurately move to all locations in the 3D space.

Dual-Loop Control

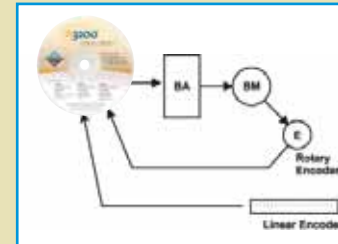

Dual-loop control is used to eliminate the effects of backlash and other sources of error.

Quadrature Encoder



Use a standard A,B quadrature encoder, incremental or absolute.

Analog Feedback



For high resolution, short travel applications, linear drives accept analog inputs from analog sensors.

Resolver/Inductosyn

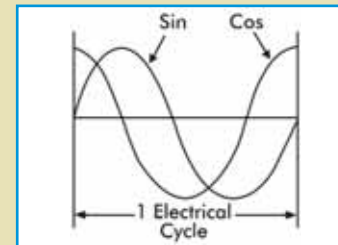

Programmable carrier frequencies make resolvers/inductosyns easy to integrate.

Laser Interferometer



Systems requiring ultra-high resolution and feedback stability use interferometer feedback.

Encoder

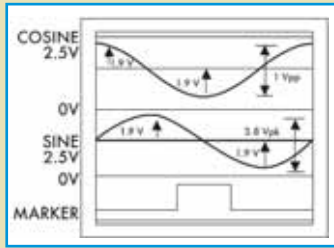

Systems requiring high resolution use a 1 V_{pp} encoder with Aerotech multiplier, up to 65,536 and 2 MHz input frequency.

Tachometer

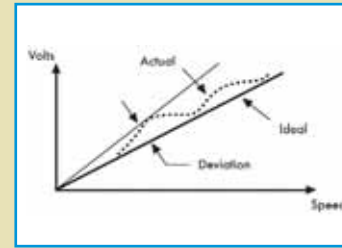

For dual feedback systems use tach for velocity control and encoder for position control.

PIDFF

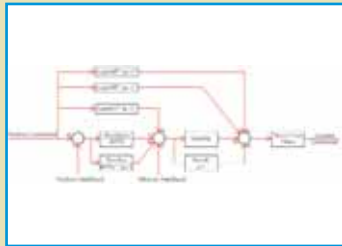

PID digital control loop with feedforward for velocity, acceleration and friction.

Safe Zones

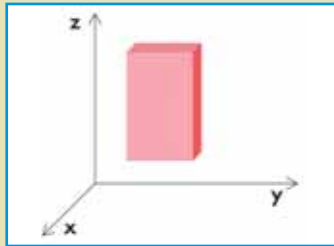

Safe zones can be set up on multi-axis systems to protect against crashes.

Slice Move

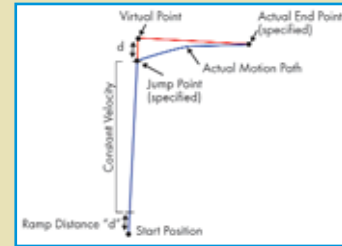

Increase scanning throughput by blending step and scan into a contoured move.

Limits



Set up hard limits and soft limits for maximum safety and flexibility.

Spindle Control



Spindle commands use standard m-codes.

CAM Profiling

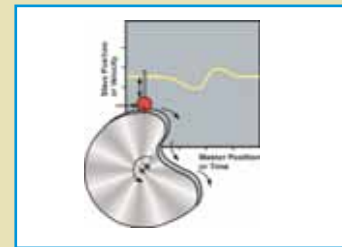

Electronically command one axis position as a function of another axis with a CAM table and fire I/O during the move.

Advanced Control: Harmonic Cancellation

- Reduce position error on periodic trajectories
- Reject periodic disturbances
- Built-in setup wizards
- Adapts to magnitude and frequency of error source

Reduce Position Error

Position error without harmonic cancellation

Continuously adapts and tracks sinusoids

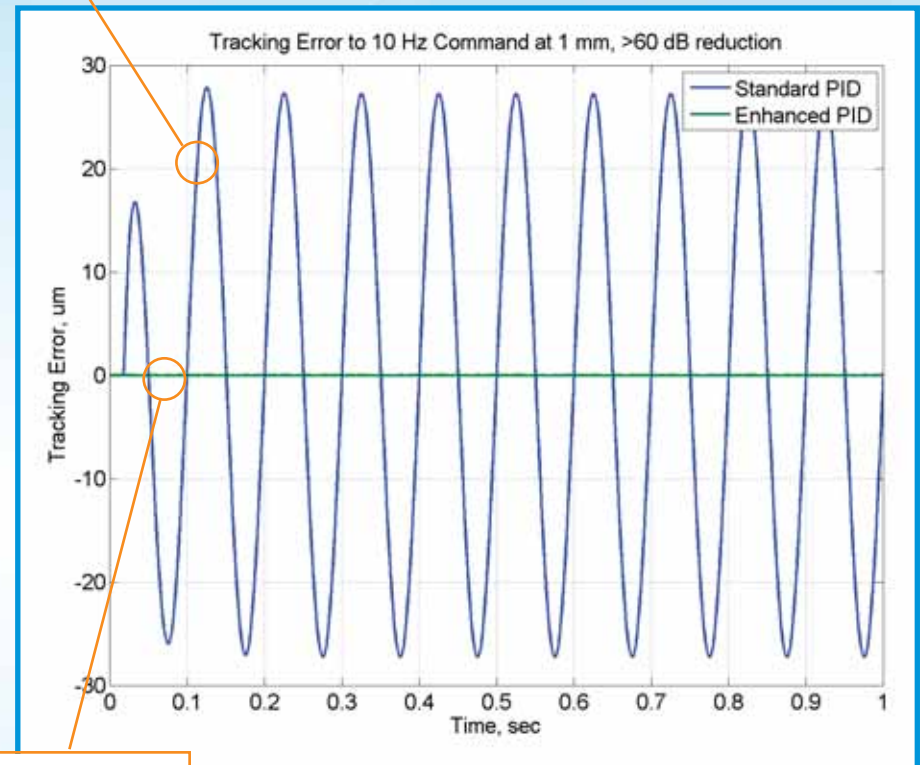

Position error with harmonic cancellation

10 Hz Command; ± 1 mm

Applications

- Machining
- Spindle Control
- Cogging Reduction
- EDM/ECM
- MEMS Sensor Testing
- R θ Wafer Inspection

Advanced Control: Iterative Learning Control

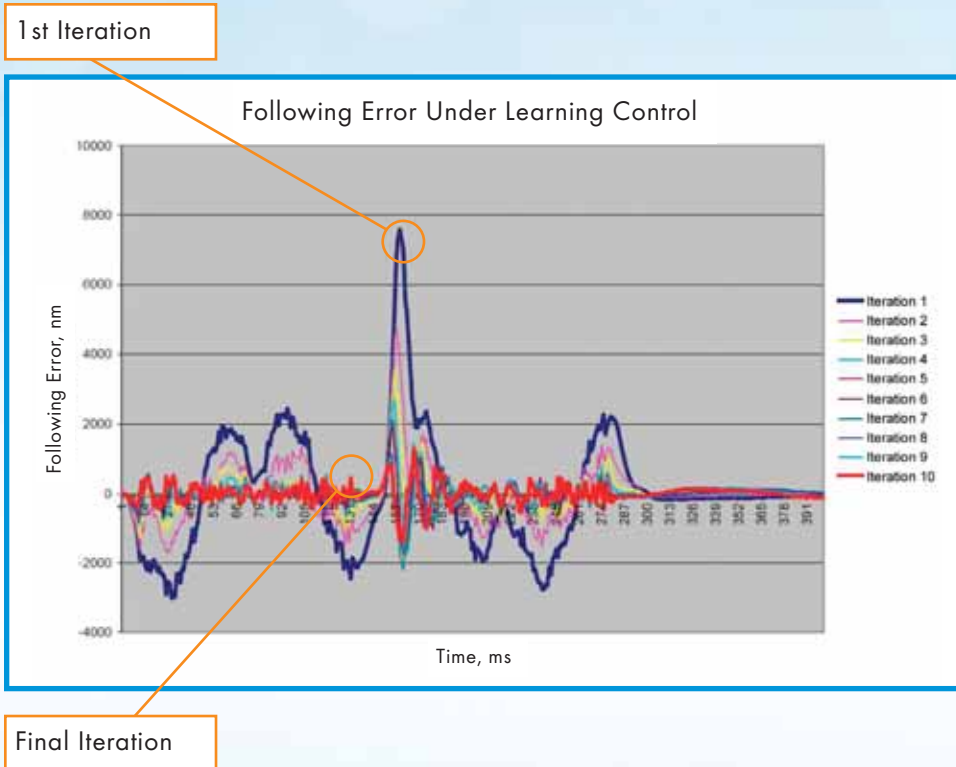

- Repeating move sequences can be learned and optimized
- Reduce following error
- Increase dynamic accuracy
- Increase production rates

Applications

- Stencil Cutting
- Stent Cutting
- Sensor Testing
- Micromachining

Advanced Control: Enhanced Throughput Module (ETM)

- Multi-axis feedforward capability
- Faster settling time
- Increase rate stability

Improved Settling Time

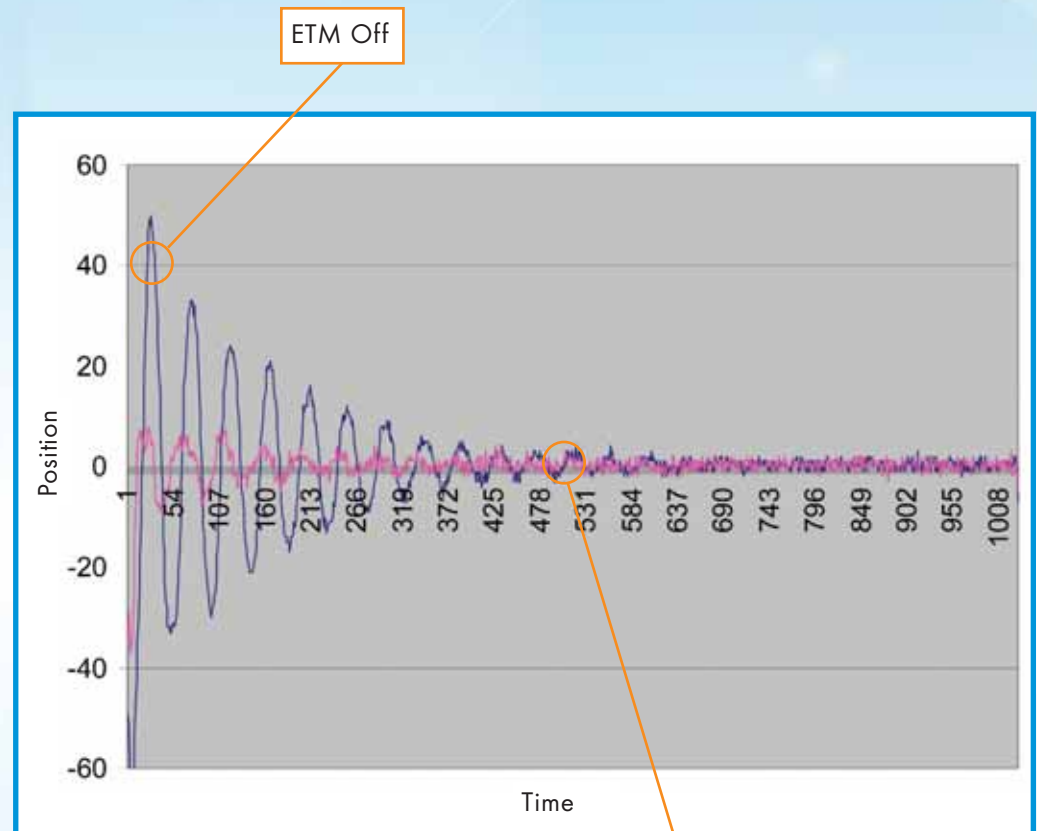

Applications

- Pick and Place Machines
- Semiconductor Inspection
- Genome Sequencing

Advanced Control: Directional Gain Scheduling

- Decrease settle time
- Increase in-position stability

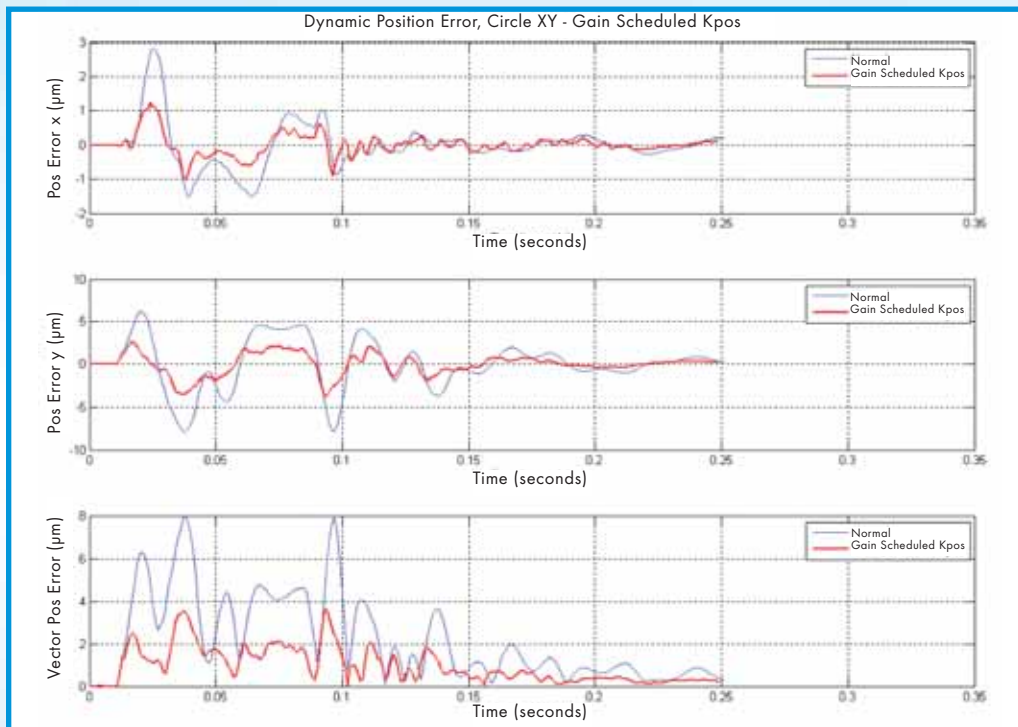

System automatically adjusts gain based on error motion during settling

Advanced Control: Gantry Control

- Both spars are programmed and commanded as a single axis
- Easy homing
- Marker offset for high accuracy
- Orthogonality correction

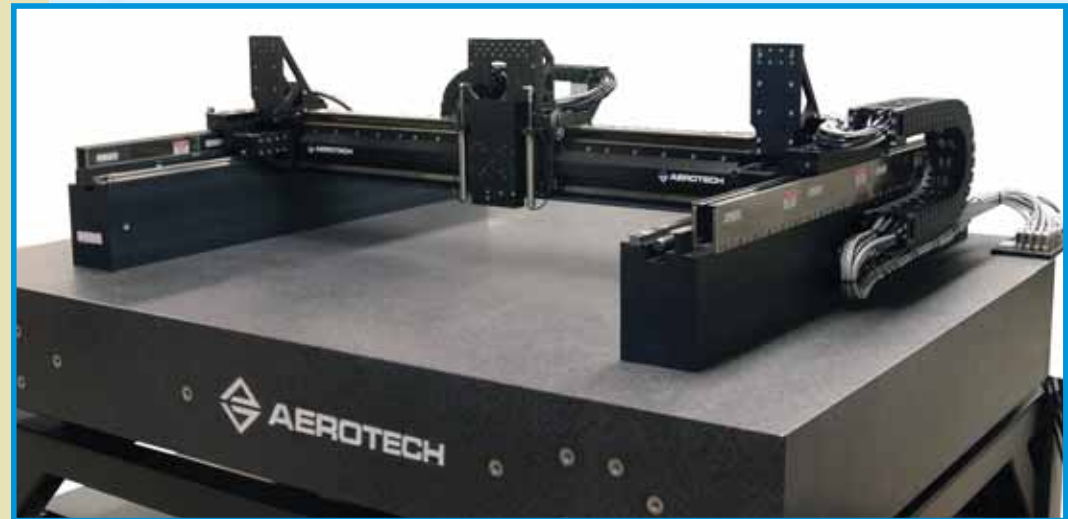

Gantry Modes

- Current Synchronization
- Position Synchronization

Gantry Configuration

- 2 Motors, 2 Encoders
- 2 Motors, 1 Encoder
- 1 Motor, 1 Encoder

Advanced Friction Model

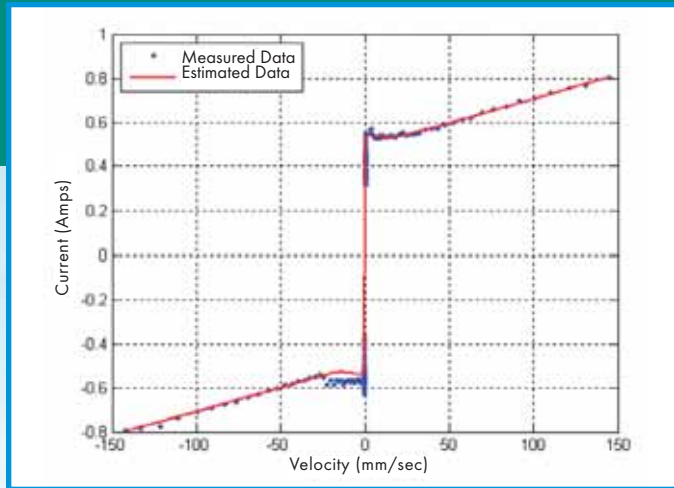

Friction Compensation Results

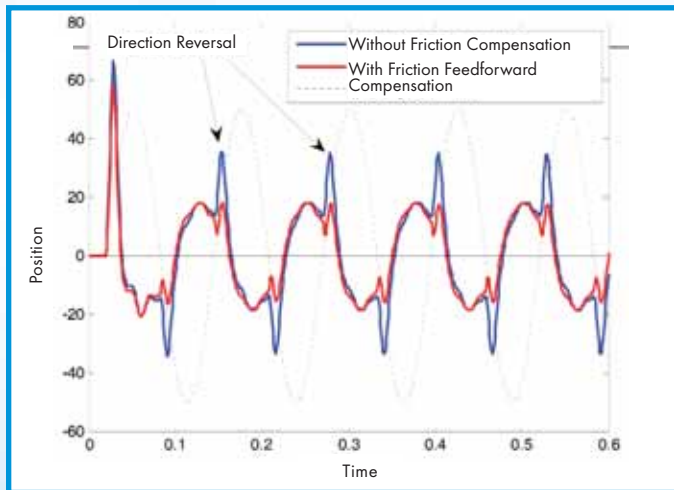

High speed, high accelerations and minimal position error achieved with feedforward additive force

Advanced Control: Friction Compensation

- Reduced settle time
- Reduced error at direction reversals

Advanced Control: Command Shaping

- Increase throughput
- Faster settle time at the work point
- No additional sensors required
- Reduced vibration in point-to-point moves
- Easy tuning

Reduce Vibration at the Work Point

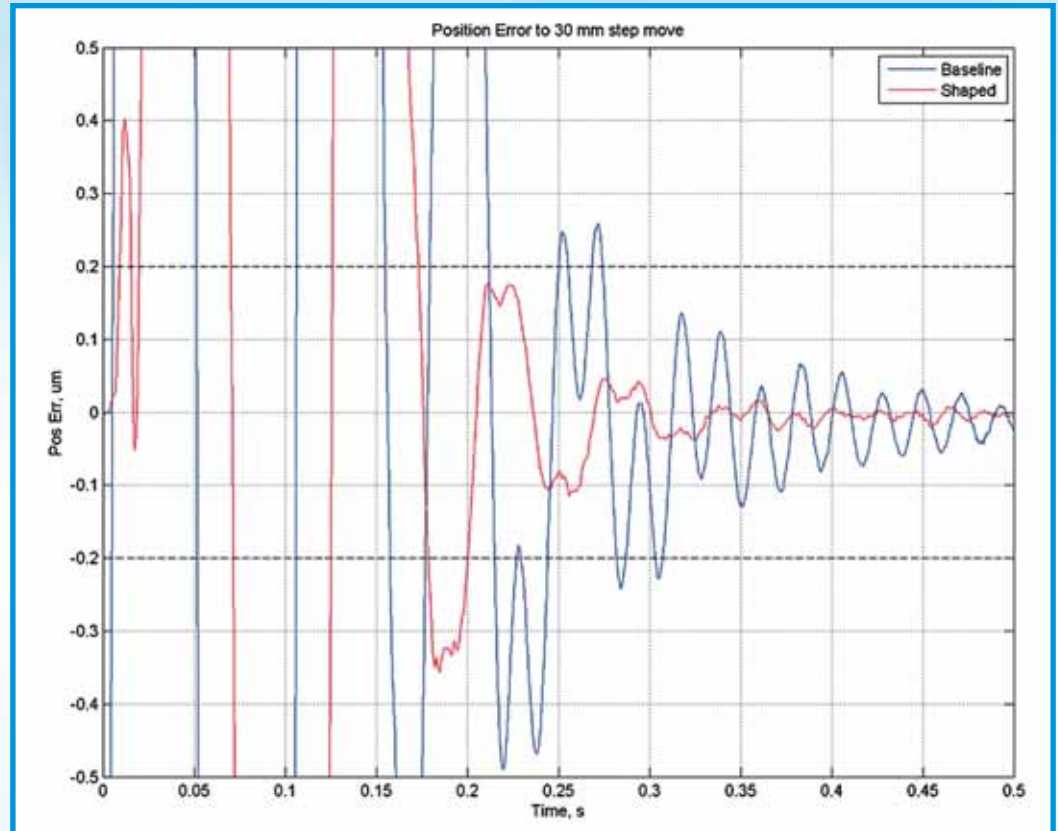

Position error at work point to 30 mm step move

Applications

- Pick and Place Machines
- Semiconductor Inspection
- Genome Sequencing

High Accuracy Firing Based on Actual Calibrated Encoder Counts

Array-Based Firing

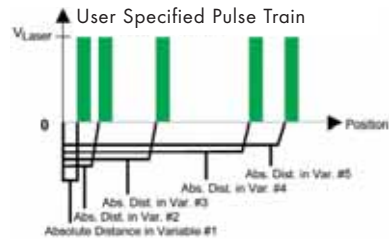

- PSO fire points are defined in an array based on calibrated position
- Pulse train specified with absolute or incremental positions
- Variable pulse width
- Specify pulse lead, pulse and pulse tail for precise energy delivery

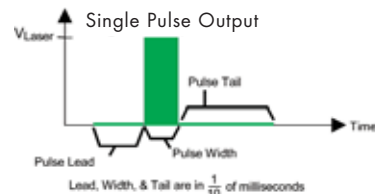
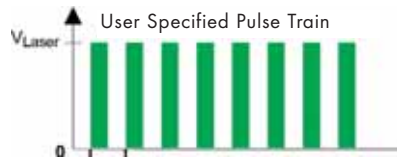

Windowing

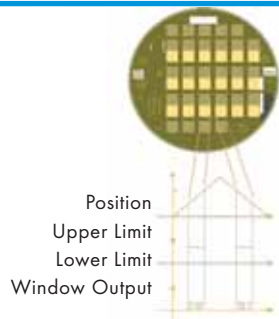

- Output pulses are constrained inside a user-defined window with the first pulse relative to the edge of the window
- Excellent when the processing of a part requires the axes to move beyond the part for settling or direction reversal in applications such as flat-panel manufacturing or fuel-injector drilling

Fixed Distance Firing

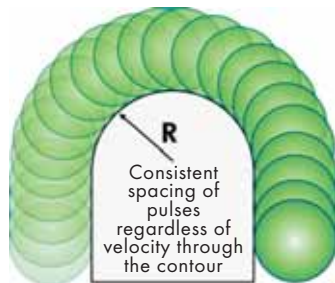

- Single- or multiple-pulse output as a function of up to 3 axes' position feedback
- Minimizes heat-affected zone in welding, cutting and drilling
- Outstanding for stent manufacturing, hermetic welding and drilling holes in turbine blades

Advanced Control: Position Synchronized Output (PSO)

- Increase throughput
- Higher accuracy
- 1-, 2- or 3-axis PSO
- Configurable command pulse train
- Use to Trigger
 - Laser firing
 - Camera capture
 - Data acquisition
 - Nondestructive test triggering

Advanced Control: Laser Marking Nmark[®] CLS

(Closed-Loop Scanner)

- Expand scanner field-of-view without sacrificing effective pixel resolution
- Mark long vectors with one continuous pass
- Draw large-scale graphics without stitching multiple exposures
- Mark on a tube or other irregularly shaped object without manually repositioning

Directly Synchronize Scanhead and Servo Motion for Ultimate Flexibility in Marking Applications

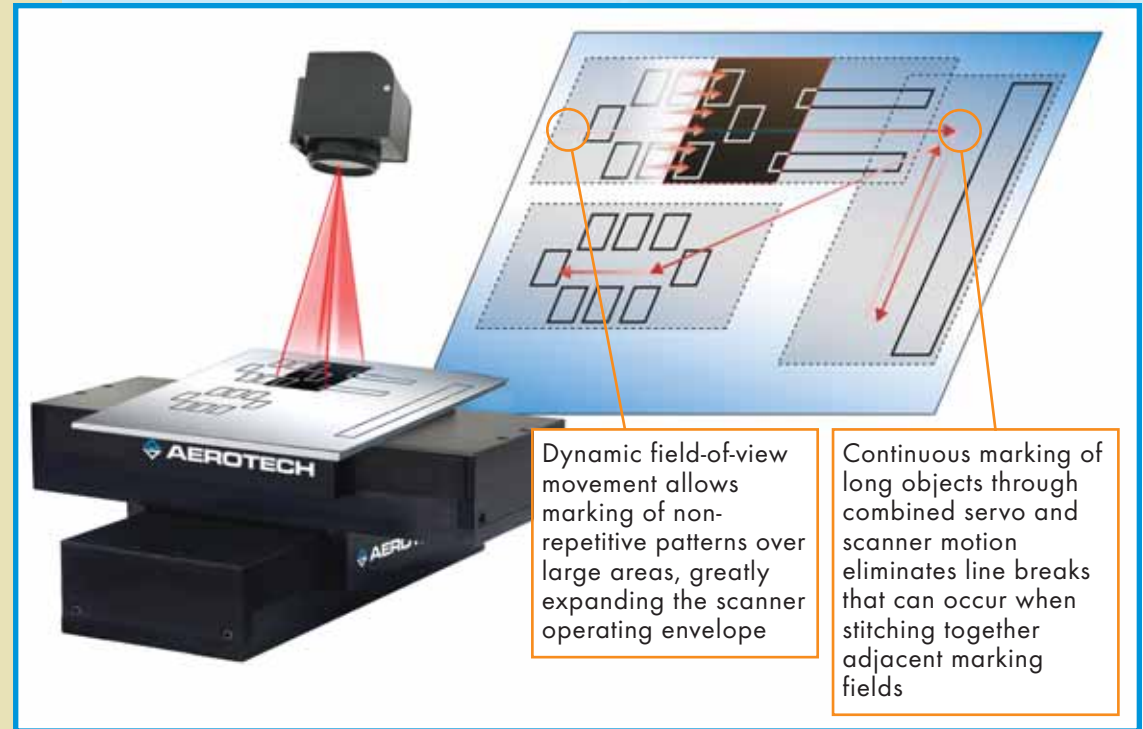

- Single programming environment for both scanner and servo axes minimizes application complexity
- Eliminate angular errors
- Scanner programmed with standard RS-274 G code
- Laser firing based on real-time scanner position

AGV Galvanometer



AGV Specifications

Mechanical Specifications	AGV-10	AGV-14	AGV-20	AGV-14HP	AGV-20HP
Beam Aperture	10 mm	14 mm	20 mm	14 mm	20 mm
Resolution	12 μ rad			0.007 μ rad	
Marking Speed	3 m/s	2.5 m/s	1.5 m/s	2.5 m/s	1.5 m/s
Positioning Speed	12 m/s	9.5 m/s	4.5 m/s	9.5 m/s	4.5 m/s
Writing Speed	900 cps	700 cps	400 cps	700 cps	400 cps
Positioning Resolution	2 μ m			1.1 nm	
Positioning Repeatability	2.4 μ m	2 μ m	2 μ m	0.32 μ m	
Positioning Accuracy	<800 μ m (standard) <50 μ m (-PLUS option)			<30 μ m (standard) <10 μ m (-PLUS option)	

- Optical feedback device offers outstanding thermal stability
- Industry-best resolution of >24 bits when used with Aerotech’s Nmark CLS controller
- Wide range of apertures and focal lengths
- Many choices of mirror surface treatments for a variety of laser wavelengths

Graphic Applications*

- Bar Code
- Serialization
- Engraving
- Character Scribing

Vector Applications

- Cutting
- Welding
- Sealing
- Ablation
- Marking

*Coming Soon

Advanced Control: Cross-Axis Feedforward

- Reduce position error on an axis due to acceleration of another axis

Reduce cross-axis position error during acceleration

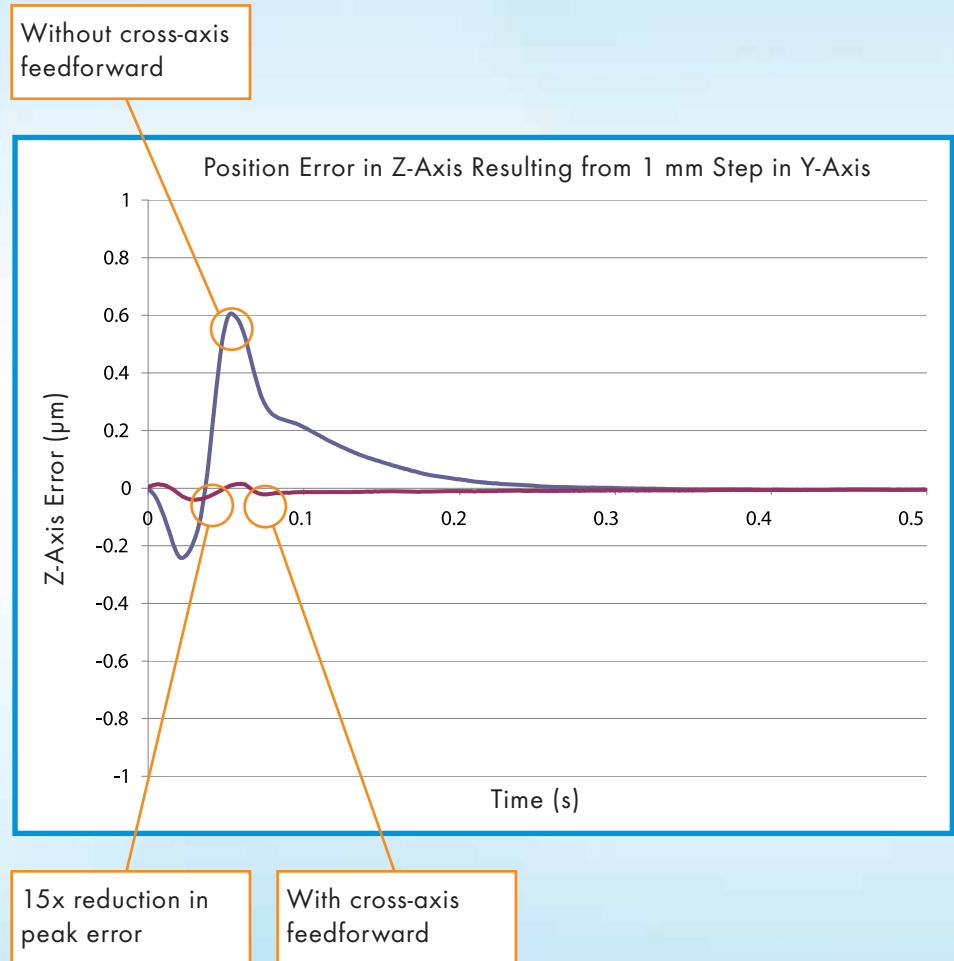

Fieldbus and Networking

Aerotech controllers support a multitude of industry-standard communication protocols to facilitate easy component networking, device connectivity and superior motion system performance.

Networking Type	Plant					Fieldbus						Motion		Drive I/O	
	Ethernet TCP/IP	USB	RS-232	RS-485	OPC*	EtherCAT	EtherNet/IP™	DeviceNet™*	CANopen*	PROFIBUS	Modbus® TCP	FireWire®	Aeronet	Analog	Digital
A3200	✓				✓	✓		✓	✓	✓		✓		✓	✓
Ensemble	✓	✓	✓	✓	✓		✓	✓	✓	✓	✓		✓	✓	✓
Soloist	✓	✓	✓	✓			✓	✓	✓	✓	✓			✓	✓
Summary	Aerotech controllers connect seamlessly to your existing corporate network or PC via these standard protocols.					Aerotech controllers support a variety of fieldbus communication protocols to fit your application.						Aerotech controllers use state-of-the-art communication standards for motion network communication to ensure a robust, high-performance system.		Aerotech drives include a standard complement of on-board analog and digital I/O, with an option for an expanded I/O board.	

*Coming Soon

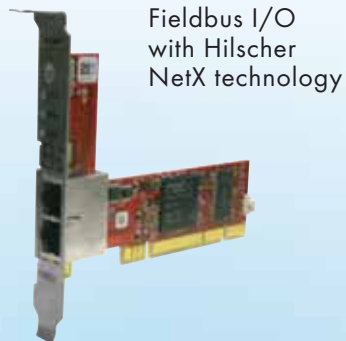

Corporate networking protocols allow remote control and monitoring of your motion system.



Fieldbus communication protocols provide extensive options for communicating with PLCs and other components in your system. Aerotech's motion networking architectures are truly plug-and-play, making setup quick and easy.

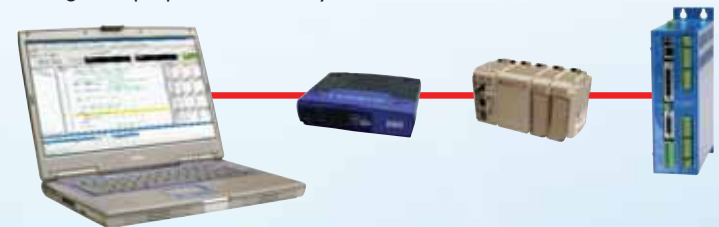

Sensor Fusion

- Data acquisition precisely integrated with motion control
- Sensor I/O easily aligned with encoder position
- Data recording and playback
- Combine sensor inputs in real time
- 5 MHz collection rates
- One easy-to-use software interface
- No additional software required
- Desktop, rack mount and panel-mount options

Sensor Fusion coupled with PSO and the Digital Scope are Aerotech's solution for all of your data acquisition needs. The Sensor Fusion can have up to four of the following card options:

As an integrated member of the A3200 motion controller family, Sensor Fusion allows you to collect position and sensor data at precisely the same time. All results can be retrieved through one easy-to-use software interface exposed through .NET, C, LabVIEW® or AeroBasic™. This tight integration cuts down on development time and eliminates a large amount of overhead in the software required to bring the entire machine to market. Available in desktop, rack mount and panel-mount versions.

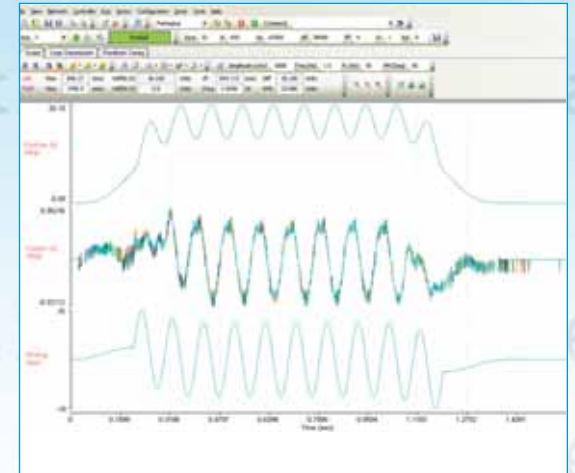

- Analog Input
- Analog Output

- Digital Input
- Digital Output

- Encoder Input
- PSO Output

Analog Input

SF-AI-01 SF-AI-02

- 16 analog inputs
- Up to 400 kHz collection
- 18-bit resolution
- Selectable input range



Analog Output

SF-AO-01 SF-AO-02

- 8 or 16 outputs
- 500 kHz playback
- 16-bit resolution
- 5 V, 10 V or external reference voltage

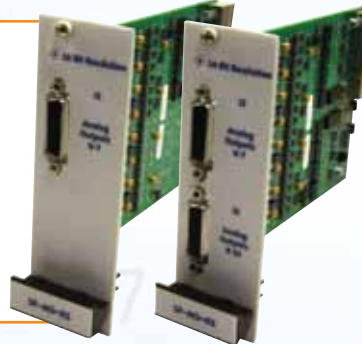

Analog Output

SF-AO-03 SF-AO-04

- 4 or 8 outputs
- 750 kHz playback
- 20-bit resolution
- 5 V, 10 V or external reference voltage



Digital Input

SF-DI-01

- 32 digital inputs
- 5 MHz collection rate
- 5 V or 24 V
- Active high or active low



Digital Output

SF-DO-01 SF-DO-02

- 32 digital outputs
- 5 MHz playback
- 32 mA at 5 V
- High power option: 325 mA at 5-24 V



Encoder Input and PSO Output

SF-ENC-01

- 4 encoder inputs (TTL)
- 1 PSO outputs
- 1.0 MHz collection



Controller Comparison Chart

Unsure about which controller is right for your application? Consult the chart to see which controller fits your needs.

Basic Functions	A3200	Ensemble	Soloist
Multi-Axis	Up to 32 axes coordinated	Up to 10 axes coordinated	Single axis
Architecture	PC-based software controller	Stand-alone	Stand-alone
Number of Tasks	32	4	4
CNC Functionality/RS-274	✓		
Coordinated Motion	✓	✓	
Point-to-Point Motion	✓	✓	✓
Cutter Compensation	✓		
Multi-Block Look-Ahead	✓		
Acceleration Limiting/Look-Ahead	✓		
Gantry Mode	✓	✓	
Velocity Blending	✓	✓	✓
Electronic Gearing	✓	✓	✓
Electronic Cam Profiling	✓	✓	✓
Arbitrary Path Generation	✓	✓	✓
Jog and Offset, Jog and Return	✓		
Velocity Profiling	✓	✓	✓
Retrace (Block by Block)	✓		
Axis Calibration	✓	✓	✓
3D Error Mapping	✓		
Sinusoidal Commutation	✓	✓	✓
Analog Power Control	✓	✓	✓
Servo, Stepper or DC Motor Controller	✓	✓	✓
Expanded IO Available	✓	✓	✓
Encoder Tuning	✓	✓	✓
Dual Loop Control	✓	✓	✓
PLC (IEC 61131-3)	✓		

Use the Best Controller for Your Application

Advanced Functions	A3200	Ensemble	Soloist
IDE	✓	✓	✓
.NET, AeroBasic™	✓	✓	✓
Fast Position Capture	✓	✓	✓
High-Speed Registration	✓	✓	✓
On the Fly End-Point Modification	✓	✓	✓
Orthogonality Correction	✓	✓	✓
Parts Rotation	✓		
Intra-Block Retrace	✓		
Iterative Learning Control	✓	✓	✓
PSO	Yes, up to 3 axes	Yes, up to 3 axes	Yes
Harmonic Cancellation	✓	✓	✓
Direction Gain Scheduling	✓	✓	✓
Inertial Damping	✓	✓	✓
Friction Compensation	✓		
Linear Drive Amplifiers	✓	✓	✓
Machine Retrofit Hardware Available	✓		
Galvo Integration	✓		
Seven Segment Acceleration Profile	✓	✓	✓
Slice Move	✓		
Corner Rounding	✓		
Coordinate Transformations	✓	With Plug-In	
Kinematics	✓	With Plug-In	
Loop Transmission	✓	✓	✓
Advanced Diagnostics and Tuning	✓	✓	✓
Auto Focus	✓	✓	✓
MATLAB®	✓		

Aerotech Electrical Value

- Wired and tested consoles
- Wired panels and 19-inch racks
- Integrated subsystem with PC, controls, drives, cables, power supply or transformer, line filtering, PLC motion, I/O and customer I/O
- CE/UL standards
- Comply with NFPA79 wiring standard

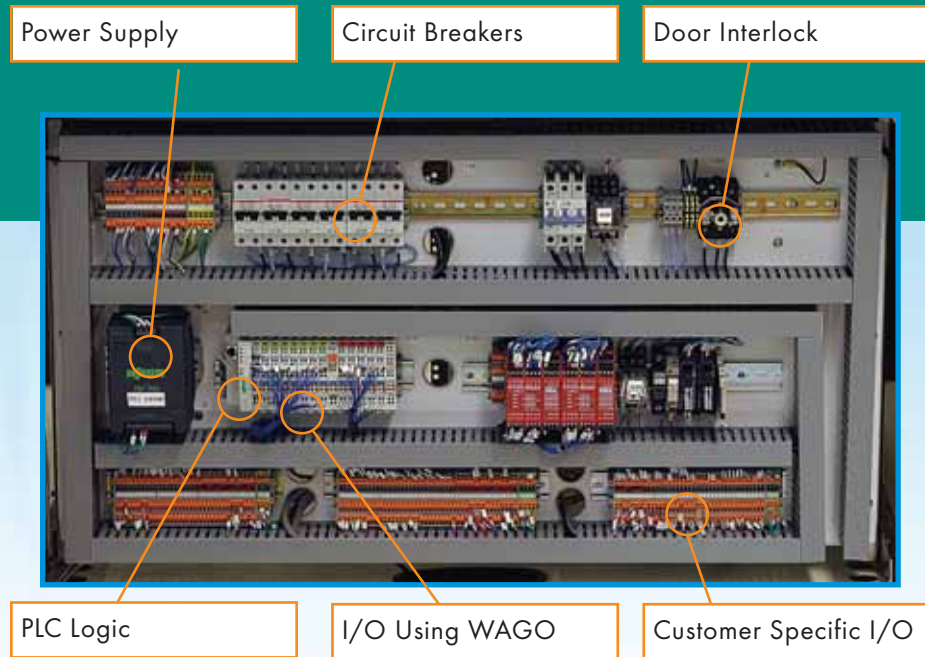

Nsys Complete Consoles

Complete consoles are available that integrate all of the electronics for your system, including the controller, drives and/or drive racks, I/O and monitor.



Aerotech Machine Safety Standards



Safety Level	Fault Detection	Loss of Safety Function Probability	Single Fault Covered	Double Fault Covered	Input ESTOP Signal	Supply Power to Drive
Category B	None	Very High	No	No	No specific design	No specific design
Category 1	None	Very High	No	No	Simple mushroom switch	One relay
Category 2	Low	High	No	No	Simple mushroom switch	One positive guided relay with auxiliary contact for checking
Category 3	Medium	Medium	Yes	No	Dual circuit mushroom with fault detection	Two positive guided relays with cross checking
Category 4	High	Low	Yes	Yes	Dual circuit mushroom with independent fault detection	Two positive guided relays with cross checking

Hardware Options

	MP	CP	HPe	CL	HLe	ML	Integrated Drive Racks		Nservo	Nstep	Nmark™	Console	
A3200 Drives							 Npaq® or Npaq MR drive chassis						
Ensemble Controls							 Epaq, Epaq MR or Ensemble LAB drive chassis and motion controller		N/A	N/A	N/A	N/A	
Soloist Controls							N/A		N/A	N/A	N/A	N/A	
Axes	1	1	1	1	1	1	1 to 8	1 to 8	2 or 4	2 or 4	3	1 to 12	
Output Type	PWM	PWM	PWM	Linear	Linear	Linear	PWM and Linear	PWM and Linear	Three-Phase ±10 V	Clock and Direction	Clock and Direction	N/A	
Peak Output Current	10 A	10-30 A	10-150 A	10 A	10-20 A	10 A	Npaq: 10-30 A Npaq MR: 10 A	Epaq/Epaq MR: 10 A Epaq: 10 A Ensemble LAB: 5 A	N/A	N/A	N/A	N/A	
DC Bus Voltage	10-80 VDC (Output)	10-320 VDC	10-320 VDC	±40 VDC	±40-80 VDC	±40 VDC	Npaq: 10-320 VDC Npaq MR: 10-80 VDC	Epaq: 24-90 VDC; ±10-40 VDC Epaq MR: 10-80 VDC Ensemble LAB: ±24 VDC	N/A	N/A	N/A	N/A	
Standard I/O	1-AI	6-DI/4-DO 1-AI/1-AO	6-DI/4-DO 1-AI/1-AO	6-DI/4-DO 1-AI/1-AO	6-DI/4-DO 1-AI/1-AO	6-DI/4-DO 1-AI/1-AO	Multiple Configurations Available	1-AI per axis	11-DI/8-DO 4-AI/2-AO	16 Assignable IO	N/A	N/A	
Optional I/O	8-DI/8-DO 1-AI/1-AO	16-DI/16-DO 1-AI/1-AO	16-DI/16-DO 4-AI/4-AO	16-DI/16-DO 1-AI/1-AO	16-DI/16-DO 4-AI/4-AO	16-DI/16-DO 1-AI/1-AO	Multiple Configurations Available	Multiple Configurations Available	Via Optional Ethernet Port	N/A	N/A	N/A	
I/O Spec	12-bit differential AI 16-bit single-ended AO	16-bit differential AI 16-bit single-ended AO					Npaq: Four 16-bit differential AI Two 16-bit single-ended AO Npaq MR: Same as ML or MP per axis		Epaq or Epaq MR: Same as ML or MP per axis	Two 16-bit differential AI Two 16-bit single-ended AO	N/A	N/A	N/A
Incremental Encoder	✓	✓	✓	✓	✓	✓	✓	✓	✓			✓	
Absolute Encoder		✓	✓	✓	✓			✓	✓			✓	
Resolver/ Inductosyn			✓		✓		✓		✓			✓	
Capacitive Probes						✓	✓						
Laser Interferometer							✓						

All units capable of sinusoidal commutation, dual-loop control and drive brushless, brush, or stepper motor

Aerotech Drive Solutions

The BA series amplifiers are Aerotech's stand-alone PWM drive for three-phase AC brushless and single-phase DC brush motors.

BL series amplifiers are highly reliable linear brushless servo amplifiers.



BA PWM Amplifiers

- Wide output power range from 10 A peak to 100 A peak at 320 VDC
- No transformer required; direct connection to AC line
- Capable of running brushless or single-phase DC brush motors
- Velocity, torque and dual-phase mode input command
- Accepts both encoder or tachometer feedback for velocity control
- Can be externally commutated
- UL, CE and CSA approval



BL Linear Amplifier

- Non-switching, high-performance linear operation for ultra-smooth control of brushless motors
- Totally modular design accepts 110 VAC or 220 VAC input power
- Ideal for air-bearing systems and noise-sensitive applications

Aerotech Servomotors

- Ironless/cogless design for superior motion
- Iron-core motors for high force output
- Frameless torque motors for custom machines
- Ultra-precision positioning
- Low heat generation
- Vacuum compatible options
- NEMA 17, 23, 34, 42 and IEC 142

Rotary Motors

Torque

Type: Brushless
 Continuous Torque: 0.16 - 31.6 N-m
Peak Torque: 0.48 - 94.9 N-m
 Rated Speed: 2400 - 4000 rpm

Torque

Type: Brushless, Slotless
 Continuous Torque: 0.33 - 2.86 N-m
Peak Torque: 1.31 - 11.43 N-m
 Rated Speed: 2000 - 4000 rpm

Torque

Type: DC Brush
 Continuous Torque: 0.25 - 1.48 N-m
Peak Torque: 1.84 - 7.1 N-m
 Rated Speed: 3000 - 6000 rpm

Torque

Type: Stepper
 Continuous Torque: 0.3 - 7.4 N-m
Peak Torque: --
 Rated Speed: --

Full line of DC brush, brushless, servo and stepper motors to fit almost any situation.

Brushless motors feature neodymium iron boron magnets for maximum torque and acceleration in a small package.



Frameless Rotary Motors

Brushless Linear Servomotors — Flat and U-Channel

Torque

Type: Frameless

Continuous Torque: 0.20 - 29.09 N-m

Peak Torque: 0.82 - 116.37 N-m

Rated Speed: 200 - 8000 rpm

Five frameless designs for easy integration into OEM machines.

Slotless stator and high-pole-count rotor provide zero cogging for exceptional velocity control.



Force

Type: Flat

Continuous Force: 19 - 697 N

Peak Force: 75 - 1507 N

Aerotech's proprietary coil winding technology produces the highest force to volume ratios available.

Direct drive, noncontactingforcer coil eliminates backlash, windup and wear for a maintenance-free system.

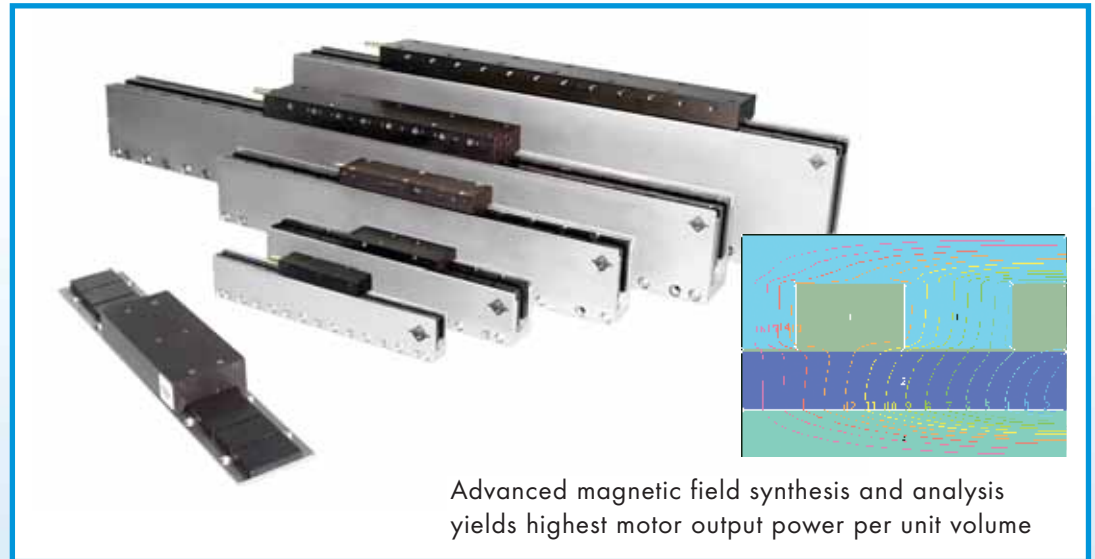

Advanced magnetic field synthesis and analysis yields highest motor output power per unit volume

Force

Type: U Channel

Continuous Force: 18.3 - 1063 N

Peak Force: 125 - 4252 N

Linear servomotors are ideal for:

- Robotics
- Packaging
- Actuators
- Tables/Stages
- Assembly
- Fiber Optics/Photonics Alignment and Positioning
- Machine Tools
- Semiconductor Equipment
- Electronic Manufacturing

Accessories

Available Accessories:

Maple Operator Interface
Joystick
Handwheel/Pendant
Transformers

Power Supplies
Cables
Automation Server
MXH Multiplier Boxes

Line Filters
Panel PC



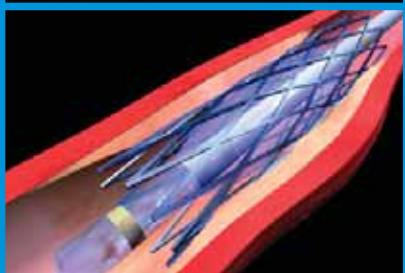

- Laser Processing
- Semiconductor Processing
- Military and Aerospace
- Electronics Manufacturing
- Medical Device Manufacturing
- Test and Inspection
- Machine Tools
- Automotive
- Packaging
- University
- Industrial R&D
- Photovoltaic Manufacturing



Markets and Industries

Aerotech controls and components have become the preferred solution for a variety of applications in a host of industries around the world.

Aerotech Customer Applications

A3200

- Stencil Cutting
- Wire Bonding
- Die Bonding
- Optics Polishing
- Stent Manufacturing
- e-Beam Welding
- EDM
- Drilling and Milling
- Grinding and Polishing
- Waterjet Cutting
- Fuel Injector Drilling
- Fuel Cell Manufacturing
- Crystallography
- Target Tracking
- Beam Steering
- Pipe Thread Measurement

A3200 or Ensemble

- Dispensing (Printed Electronics, Material Dispensing)
- PCB Assembly (Pick and Place of SMT, Through-Hole)
- VIA Drilling
- Wafer Scribing and Singulation (Dicing)
- Die Bonding
- Resistor Trimming
- AOI/X-Ray Inspection
- Chip Testing
- Chip Packaging
- Crystallography
- Flat Panel
- Semiconductor Testing
- Semiconductor Manufacturing
- Photovoltaic Cell Manufacturing
- DNA Analysis
- Image Duplication
- Holographic Writing
- Sensor Testing
- Sensor Manufacturing

Ensemble

- Packaging Machines (Multi-Axis Applications)
- Web Applications
- Printing Applications
- Rollover Unit Testing
- IMU Testing
- ECM
- Marking
- Vertical Form, Fill, and Seal

Soloist

- EDM & ECM
- Packaging Machines (Case Erectors, Labeling Machines, Augers)
- Printing
- Gyro Testing
- Accelerometer Testing
- Optical Polishing (Spindle Axis)
- Beam Steering

Stent and Medical Device Manufacturing

Aerotech's experience in market-specific solutions provides an edge in processes involving photonics, semiconductor processing, medical device manufacturing and laser processing. With a number of specially developed motion platforms for these industries, Aerotech provides a one-stop-shop for your motion requirements.

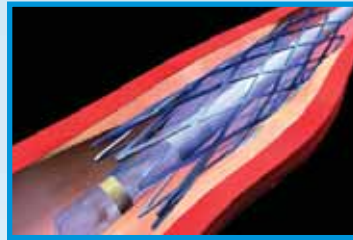

Aerotech's highly successful VascuLathe® and LaserTurn® platforms deliver maximum productivity in a compact, easy to maintain package with the lowest cost of ownership in the industry. With the A3200's PSO functionality, the throughput possible with the LaserTurn® and VascuLathe® series is unmatched.

Controllers to Use:

- A3200



Solar Panel Scribing

Extensive application experience and a broad array of motion products make Aerotech the perfect partner for your photovoltaic (solar cell) manufacturing or testing platform. Our worldwide operation has engineered and manufactured a multitude of motion platforms for solar cell manufacturing and inspection. These platforms range from small format systems for R&D to full-size production panel processing systems.



Controllers to Use:

- A3200
- Ensemble

Packaging

Line following applications including:

- Labeling, cut-to-length, fly cutting, lane diversion, rotary knife and many others.

Basic features for line following:

- Auxiliary encoder input for measuring line speed
- High-speed registration for measuring line position
- The relationship between line speed/position can be an arbitrary function or simply 1-to-1

Controllers to Use:

- Soloist
- Ensemble
- A3200

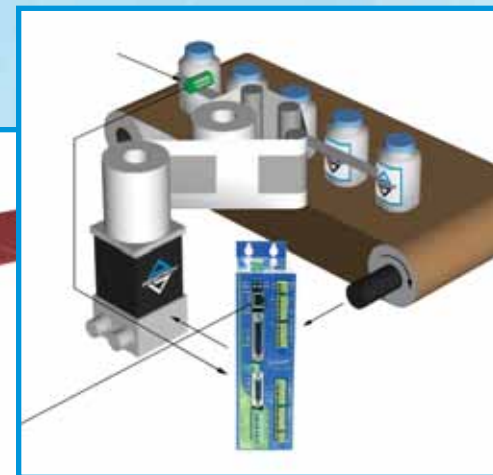
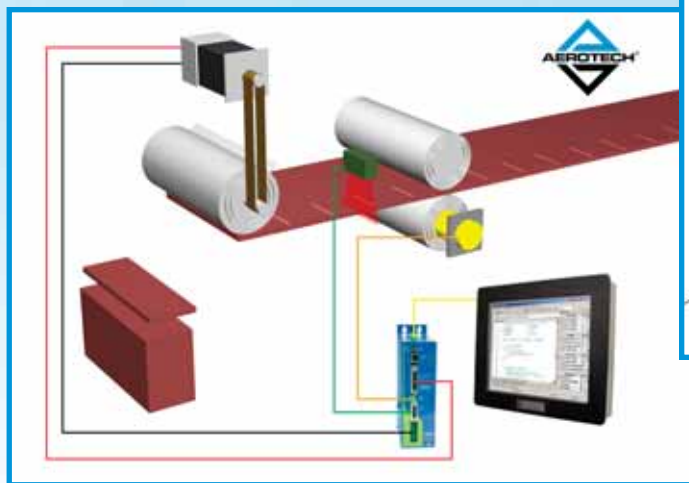

High Accuracy, Multi-Axis Inspection Systems

The A3200 controller is uniquely suited to complex inspection applications like turbine blade inspection that requires 5 axes or more of coordinated motion integrated with a sensor or camera.

Controllers to Use:

- A3200 with linear drives

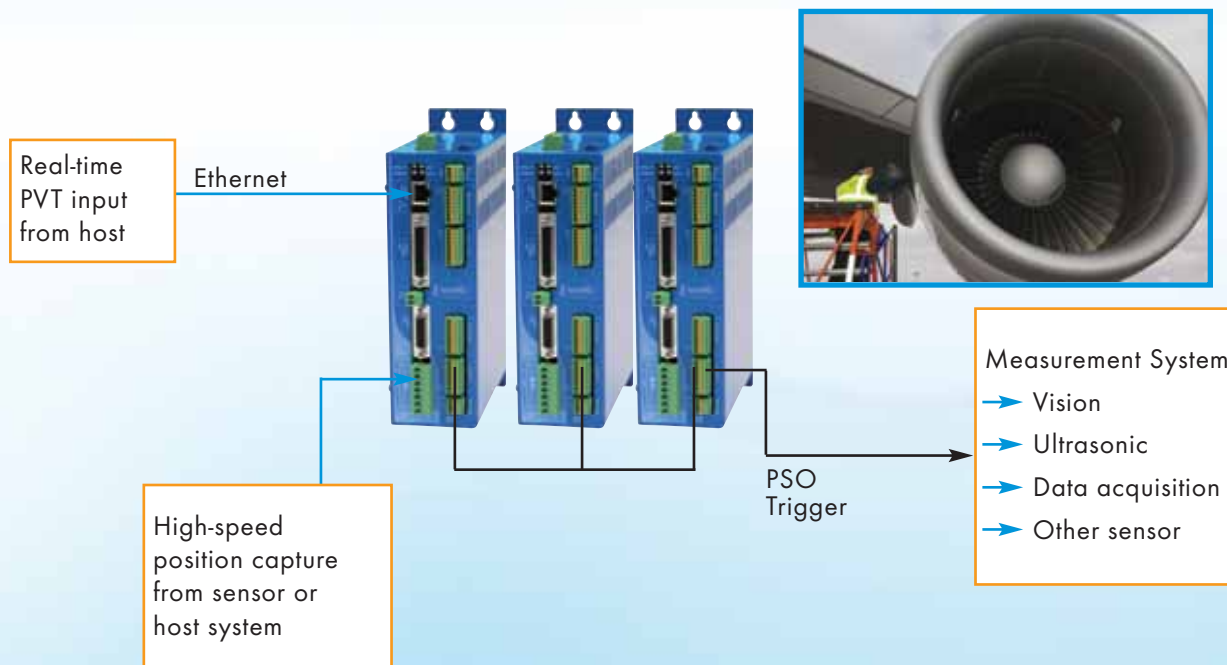

Optical Mounts and Gimbals

- Directing optics, lasers or antennas
- LOS target tracking
- Precision pointing

Controllers to Use:

- A3200
- Ensemble



Fuel Cell Manufacturing Operations

- Laser machining the membranes (also referred to as MEAs)
- Welding the plates/membranes together
- Stacking the membranes into a cell
- Inspection of the MEAs, plates and cells

Controllers to Use:

- A3200

Controls Timeline

With 40 years in the business of designing and building motion systems, Aerotech has the experience and knowledge to understand the challenges and solutions of industrial and laboratory processes.



Aerotech has manufactured advanced motion controllers since 1970. From the industry workhorse PCI cards to state-of-the-art software-based control coupled with intelligent networked drives, the science of motion control has been our business for decades.



Worldwide Training and Support

Aerotech offers comprehensive worldwide training and customer service at customer facilities or at one of our Aerotech training centers.

Training Program:

- Standard and customized courses
- Hands-on training with Aerotech controllers
- Interactive training with experienced instructors
- Comfortable, spacious facilities
- Online training modules
- Online FAQs
- At customer site or at Aerotech

Installation and Startup (Commissioning)

Aerotech offers startup and commissioning services to minimize startup times, reduce costs and accelerate time-to-production. By combining our product knowledge with your process and application expertise, new systems and applications can be completed faster and at a reduced overall cost.

Engineering Support

Aerotech provides complete engineering support for our products, including onsite support and maintenance, and remote support via phone, fax, website and/or WebEx® software. As a manufacturer staffed by engineers, we understand the unacceptability of downtime.

WebEx®

Aerotech can remotely support your startup, commissioning and debugging of systems over the internet.

Aerotech is an ISO 9001 Registered Company



Aerotech Inc (U.S.A.)



Aerotech Ltd (United Kingdom)



Aerotech GmbH (Germany)



Aerotech KK (Japan)

Since 1995, Aerotech's quality system has been certified to the ISO 9001 standard. The ISO 9001 standard encompasses the Aerotech organization through manufacturing.

As part of our commitment to the ISO standard, we formally survey our customers on a monthly basis which provides valuable feedback to continually improve our products and processes.

Aerotech at a Glance

High-Volume Manufacturing

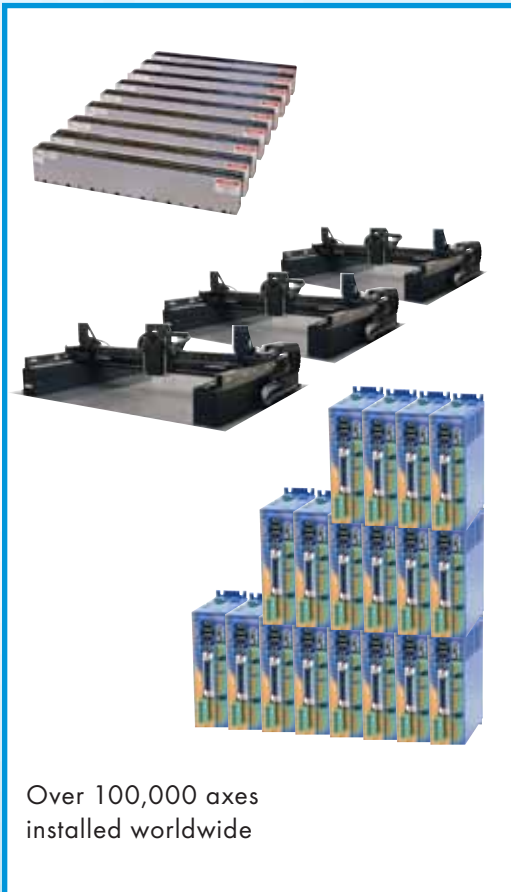

Over 100,000 axes installed worldwide

Worldwide Service and Support



Worldwide startup service and on-site training

Fully equipped on-site training facilities

Technically Superior Components



Highest performance brushless linear and rotary motors

ADRT rotary stages

ALS1000 linear motor stage

A3200

Soloist®

Ensemble®

Award-winning Automation 3200
1-32 axis motion, vision, PLC, robotics
and I/O platform



Corporate Headquarters • Pittsburgh, PA • USA Aerotech UK Aerotech Germany Aerotech Japan Aerotech China

High Performance Sub-Assemblies



XYAB subsystem for high dynamic accuracy positioning in laser drilling and micromachining applications

LaserTurn® 5 high-speed cylindrical laser cutting system



Highest throughput linear motor Cartesian gantry systems

Best-in-Class Subsystems

Highly integrated motion subsystems with machine frame, display and packaged electronics



Custom-engineered, vacuum and cleanroom compatible systems



Production-proven, large format air-bearing systems for flat panel and semiconductor applications



Comprehensive Technical Support Services



Custom software application support

3D models to facilitate faster and more accurate system layout

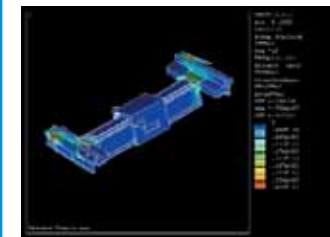
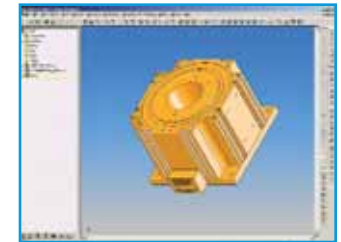

Advanced analytical techniques for optimization of system geometry

Aerotech Worldwide



- ★ - Aerotech Headquarters
- - Direct Field Sales Office
- ▲ - Aerotech Subsidiary
- - Representative

www.aerotech.com