

# Instrumentation Products

## Needle Type Globe Valves and Accessories



# Introduction

## Introduction

The AS-Schneider Group with its headquarters in Germany is one of the World's Leading Manufacturers of Instrumentation Valves and Manifolds. AS-Schneider offers a large variety of Needle Type Globe Valves for General and Severe Service applications for liquids, gases and steam but also Accessories needed for the instrumentation installations globally.

Selection can be made from a comprehensive range of bodies with a variety of connections and material options, optimising installation and access opportunities. Many of the valves shown in this catalogue are available from stock or within a short period of time. The dimensions shown in this catalogue apply to standard types. If you need the dimensions for your individual type please contact the factory.

Continuous product development may from time to time necessitate changes in the details contained in this catalogue. AS-Schneider reserves the right to make such changes at their discretion and without prior notice.

All dimensions shown in this catalogue are approximate and subject to change.

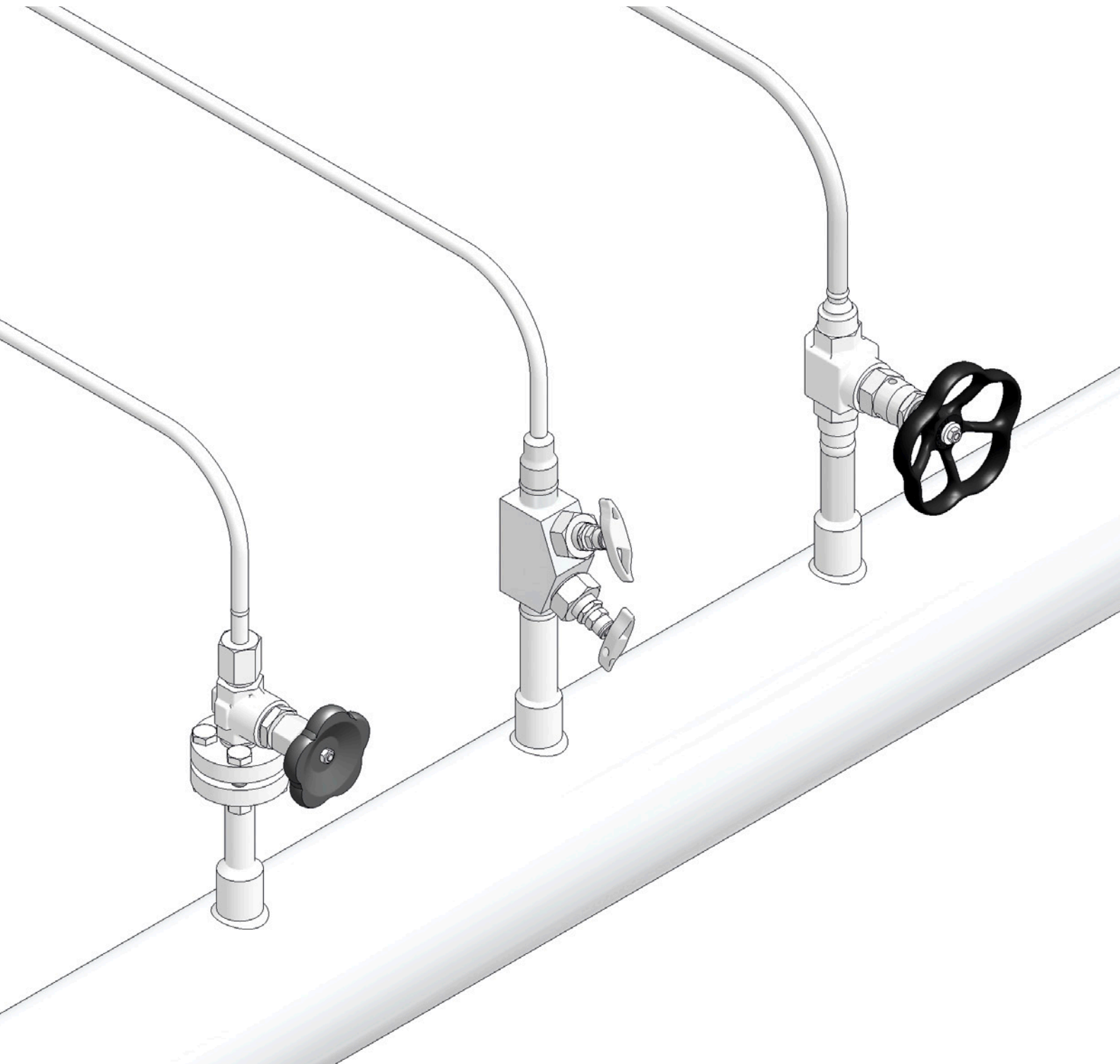

<b>Introduction</b>	page 2
<b>Contents</b>	page 3
<b>Needle Type Globe Valves Overview</b>	page 4-5
<b>General Features and Connections</b>	page 6-8
<b>Integral Bonnet Needle Valves Type S338</b>	page 9-10
<b>Screwed Bonnet Needle Valves Type S350, S351</b>	page 11-14
<b>Angle Needle Valves Type S360</b>	page 15
<b>Y-Pattern Needle Valves Type S371</b>	page 16
<b>Screwed Bonnet Needle Valves Type S340, S381</b>	page 17-18
<b>Union Bonnet Needle Valves Type A1, B1</b>	page 19-20
<b>Bolted Bonnet Needle Valves Type A2</b>	page 21
<b>Welded Bonnet Needle Valves Type A4</b>	page 22
<b>Ordering Information for Needle Valves Type A1, B1, A2, A4</b>	page 23
<b>Condensate Pots, Weld Fittings and Threaded Pipe Ends</b>	page 24-27

# Needle Type Globe Valves Overview

## Type S338

### Integral Bonnet Needle Valves DN 6 / Bore Size 6 mm

- Forged Body
- Integral Bonnet
- Integral Valve Seat
- Internal Stem Thread

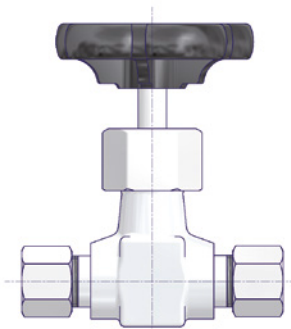

## Type H

### E Series Needle Valves DN 5 / Bore Size 5 mm

- Barstock Body
- Screwed Bonnet
- Integral Valve Seat
- External Stem Thread

Detailed information see Catalogue  
AS-2601 – E Series Valves and  
Manifolds - Hand Valves.

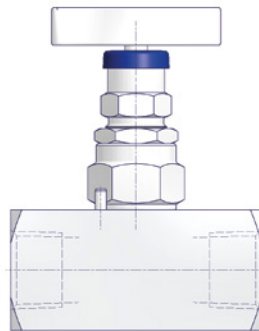

## Type S350 / S351

### Needle Valves DN 8 / Bore Size 8 mm

- Forged Body
- Screwed Bonnet
- Replaceable Valve Seat
- Stem Thread
  - S350 with Internal Stem Thread
  - S351 with External Stem Thread
  - F350 Bellows Sealed Option

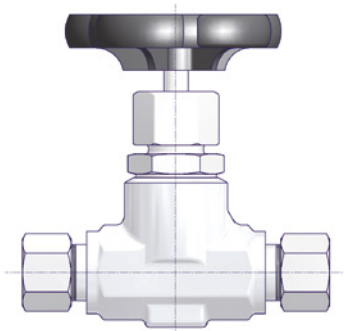

## Type S360

### Angle Needle Valves DN 8 / Bore Size 8 mm

- Forged Body
- Screwed Bonnet
- Integral Valve Seat
- Internal Stem Thread

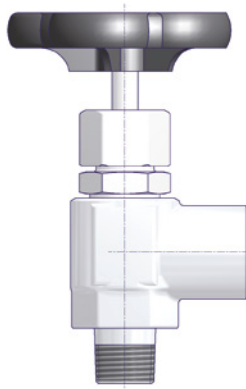

## Type S371

### Y-Pattern Needle Valves DN 8 / Bore Size 8 mm

- Forged Body
- Screwed Bonnet
- Integral Valve Seat
- External Stem Thread

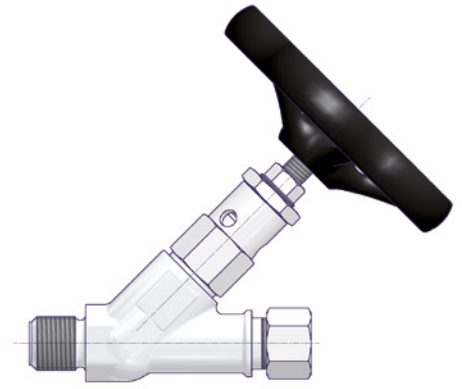

**Straight Pattern**

**Angle Pattern**

**Y-Pattern (Oblique Pattern)**

## Valve Patterns

# Needle Type Globe Valves Overview

## Type S340 / S381

### Primary Isolation Valves DN 8 / Bore Size 8 mm

- Forged Body
- Screwed Bonnet
- Replaceable Valve Seat
- External Stem Thread

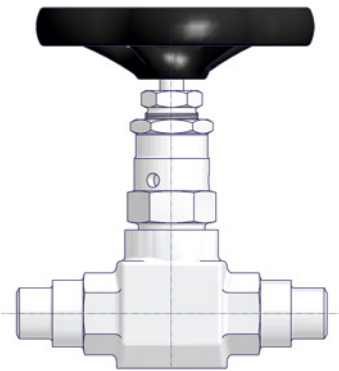

## Type A1 / B1

### Union Bonnet Needle Valves Type A1: DN 11 / Bore Size = 11 mm Type B1: DN 8 / Bore Size = 8 mm

- Barstock Body
- Union Bonnet Design
- Integral Valve Seat
- External Stem Thread

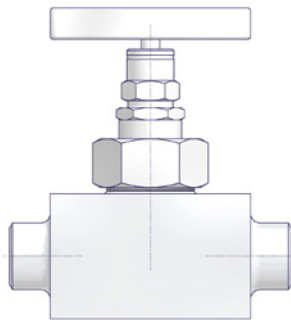

Type A1

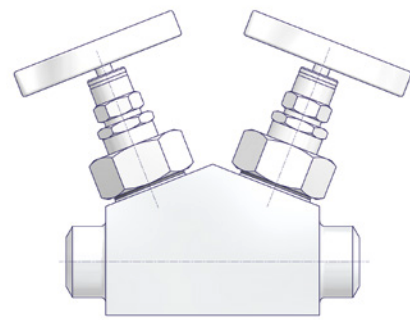

Type B1

## Type A2

### Bolted Bonnet Needle Valves DN 20 / Bore Size 20 mm

- Barstock Body
- Bolted Bonnet Design
- Integral Valve Seat
- External Stem Thread

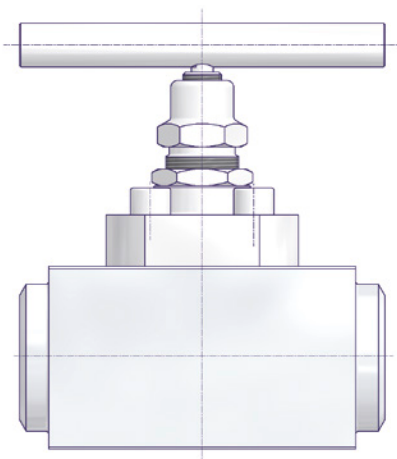

## Type A4

### Primary Isolation Valves DN 10 / Bore Size 10 mm

- Barstock Body
- Welded Bonnet (extended)
- Integral Valve Seat

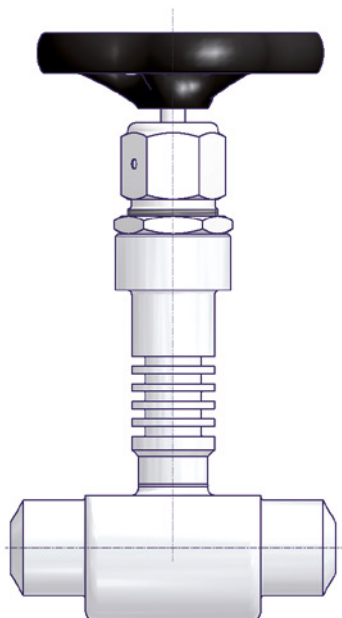

# General Features

## Body Material Options

Material Group	AS Material Designation	Material No.	Short Name	Equivalent UNS-No.	Material Grade acc. to ASTM	S338	N334	H*4	S350 / S351	S340 / S381	A1	B1	A2	A4
Heat Resistant Unalloyed Steel	A105						S	O						
	1.0460 / A105N*1					S			S	S				
Austenitic Stainless Steel		1.4571	X6CrNiMoTi17-12-2	S31635	316Ti	S		O	S	S				
	316 Quadruple Certified*2	1.4401	X5CrNiMo17-12-2	S31600	316								S	S
		1.4404	X2CrNiMo17-12-2	S31603	316L		O	S						
		1.4919	X6CrNiMo17-12-2	S31609	316H						S			
	6 Mo	1.4547	X1CrNiMoCuN20-18-7	S31254				S						
Austenitic-Ferritic Stainless Steel	Duplex	1.4462	X2CrNiMoN22-5-3	S31803	F51			S				O		
	Superduplex	1.4410	X2CrNiMoN25-7-4	S32750	F53			S				O		
		1.4501	X2CrNiMoCuWN25-7-4	S32760	F55			S				O		
Heat Resistant Steel		1.5415	16Mo3							S		S	O	
		1.7335	13CrMo 4-5		F12					S*3		S		
		1.7383	10CrMo 9-10		F22					S*3		S	O	
		1.4901	X10 CrWMoVNb 9-2		F92					O				S
		1.4903	X10 CrMoVNb 9-1		F91					O	S	S	S	O
		1.4981	X8 CrNiMoNb 16 16											
Nickel Based Alloys	Alloy 400	2.4360	NiCu30Fe	N04400				S				O		
	Alloy C-276	2.4819	NiMo 16 Cr 15 W	N10276				S				O		
	Alloy 625	2.4856	NiCr22Mo9Nb	N06625				S				O		
Titanium	Titanium Grade 2	3.7035	Ti-II	R50400				S						

\*1 Dual Certified

\*2 Quadruple Certified means 316 / 316L / 1.4401 / 1.4404

\*3 Dual Certified EN/ASTM

\*4 See Catalogue AS-2601 - E Series Valves and Manifolds - Hand Valves

S = Standard | O = Optional

## Standard Features

### Packing:

PTFE and Graphite Packings are available for all valve types.

### Surface Treatment:

Carbon Steel Valves are phosphatized by default.

### Pressure Test:

A shell test and a seat test are performed at 1.5 times the max. allowable (working) pressure acc. to EN 12266-1 - P10, P11 and P12 respectively MSS-SP61 at every standard AS-Schneider Needle Type Globe Valve.

### Certification:

Inspection certificate 3.1 acc. to EN 10 204 for valve body material and pressure test available on request. The heat resisting materials (see table on Page 6) are available by default with inspection certificate 3.2!



**Packing adjustment may be required during the service life of the valves.**



**Valves that have not been cycled for a period of time may have a higher initial actuation torque.**



**When delivered ex factory, the safety packing of the bellows sealed valve is not fully tightened. In the event of a bellows failure the safety packing must be tightened in order to avoid fluid leakage.**

## Valve Head Unit Options

### Internal Stem Thread

Internal Stem Thread means Threads are in contact with process media.

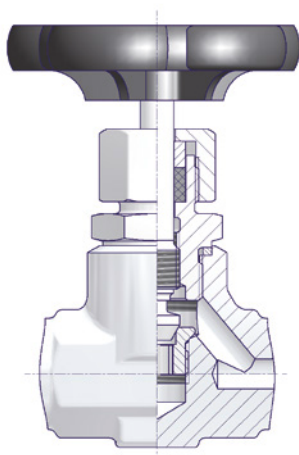

### Stem Features

- Stem with cold rolled threads
- Back seat (except Integral Bonnet Needle Valve)
- Non-rotating needle tip or alternatively non-rotating needle

### Valve Seat (Metal to Metal)

- Integral Valve Seat or Replaceable Valve Seat

## Optional Features

### Fugitive Emission Applications:

For Fugitive Emission Applications AS-Schneider is providing bellows sealed valves with safety packing. Choice of Pressure class PN 100 or PN 250 - Suffix P5 or P6.

The bellows are submitted to a 100% Helium leak test. Leak rate:  $10^{-8}$  mbar l/s.

Optional available are TA-Luft and ISO 15848 solutions. For more details please contact the factory.

### Oxygen Service:

AS-Schneider offers an option with Reinforced PTFE Packing cleaned and lubricated for Oxygen Service – Suffix F5:

Pressure-Temperature Rating:

Max. 420 bar @ 60°C

Max. 200°C @ 90 bar

Not every Valve type is available for Oxygen Service.

**If you don't find your options in this catalogue, please contact the factory.**

### External Stem Thread

External Stem Thread means Packing below Stem Threads. Stem Threads are protected from process media (non-wetted), helps to prevent stems from galling.

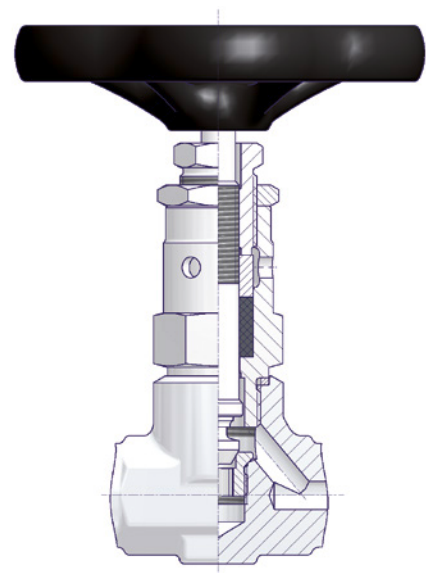

## Connections

AS-Schneider is manufacturing a lot of different connections and connection combinations. In this catalogue we are showing the most popular types. On this page you will find the standard connections in detail.

### Tube Fittings

Single Ferrule Tube Fittings  
acc. to EN ISO 8434-1 Size S

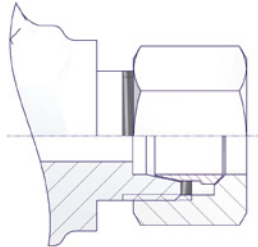

Twin Ferrule Tube Fittings

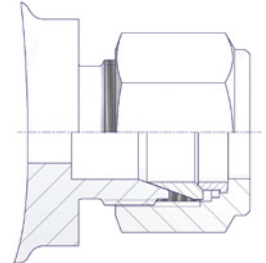

### Tapered Pipe Threads

NPT Male Threads  
acc. to ASME B 1.20.1

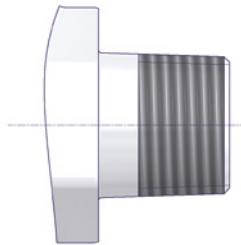

NPT Female Threads  
acc. to ASME B 1.20.1

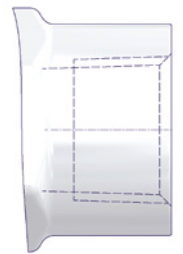

### Parallel Pipe Threads

BSP Parallel Male Threads  
acc. to DIN 19207 (G1/2)  
acc. to DIN 3852

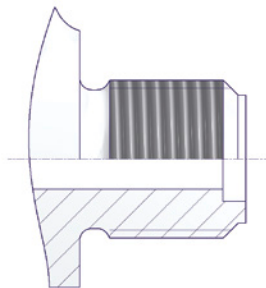

BSP Parallel Female Threads  
acc. to ISO 228 (e.g. G 1/2)  
acc. to DIN 3852-2 Form Z

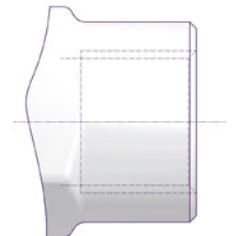

### Weld Ends

Butt Weld Ends  
for Pipes and Tubes  
acc. to ASME B16.9 and  
EN 12627

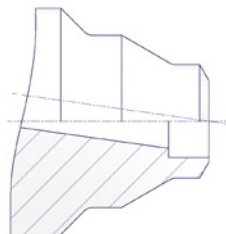

Socket Weld Ends  
for Pipes and Tubes  
acc. to ASME B16.11 and  
EN 12760



Combination of Pipe Butt  
Weld End x Tube Socket  
Weld End

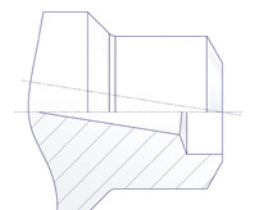

# Integral Bonnet Needle Valves

## Features

- Forged Body - DN 6 / Bore Size 6 mm
- Integral Bonnet
- Integral Valve Seat
- Internal Stem Thread
- Stem with cold rolled surface and non-rotating needle tip
- Standard-Packing PTFE (max. 232°C)
- Optional Graphite Packing (max. 300°C)

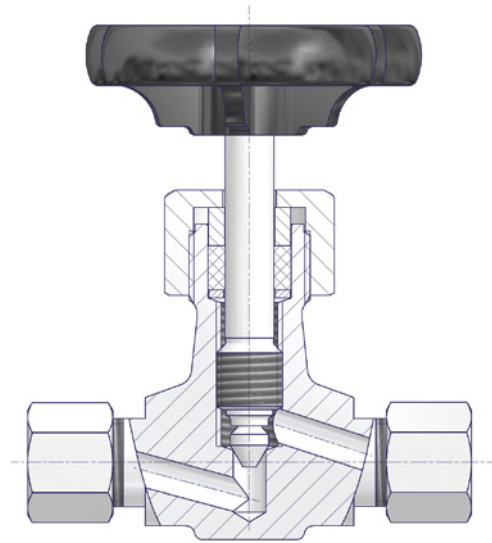

Components	Carbon Steel	Stainless Steel
	Material / Material No.	
Body	1.0460 / A105	1.4571
Valve Stem	1.4104	
Needle Tip	1.4122	
Packing	PTFE (Optional Graphite)	
Union Nut	Unalloyed Steel	1.4571
Tube Fitting		
Handwheel	Plastic	

## Pressure-Temperature Ratings

### Series S

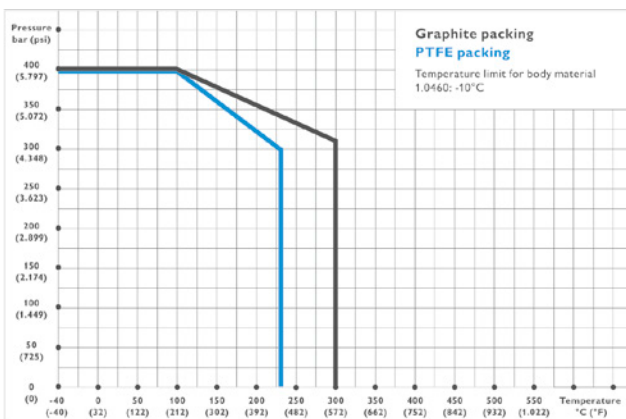

### Series L

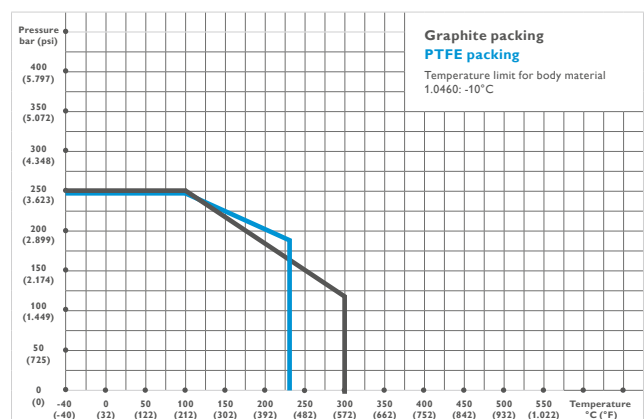

# Needle Valves Type S338

## Tube Fitting Connections Size S/L

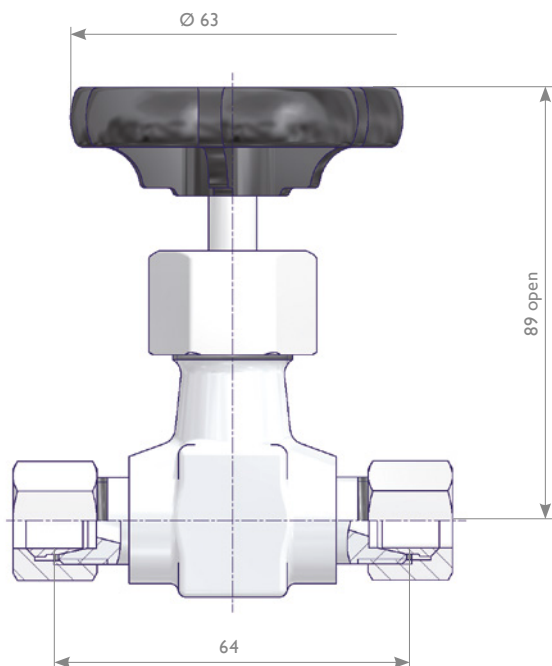

Inlet	Outlet	Part Number	
		Material	
Tube Fitting Sizes		1.0460 / A105	1.4571
6S		S338.03.130	S338.03.230
8S		S338.03.120	S338.03.220
10S		S338.03.110	S338.03.210
12S		S338.03.100	S338.03.200
6L		S338.03.180	S338.03.280
8L		S338.03.170	S338.03.270
10L		S338.03.160	S338.03.260
12L		S338.03.150	S338.03.250

## Female Threads

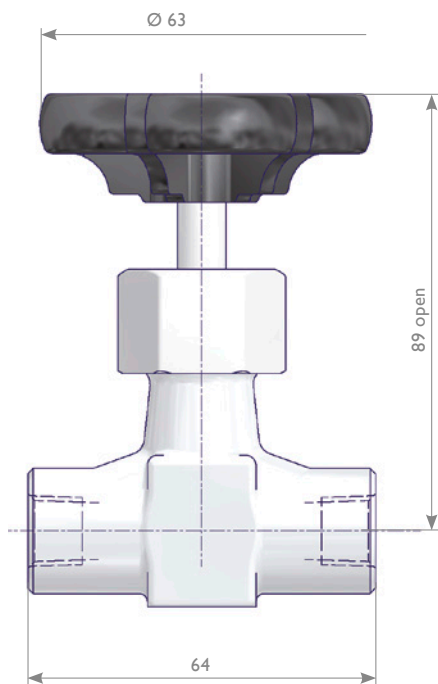

Inlet	Outlet	Part Number	
		Material	
		1.0460 / A105	1.4571
1/4 NPT Female		S338.08.110	S338.08.210
G 1/4 Female		S338.08.115	S338.08.215
G 3/8 Female		S338.08.116	S338.08.216

# Screwed Bonnet Needle Valve Type S350 / S351

## Features

- Forged Body - DN 8 / Bore Size 8 mm
- Screwed Bonnet
- Replaceable Valve Seat
- Stem with cold rolled surface, back seat and non-rotating needle tip

### S350 with Internal Stem Thread

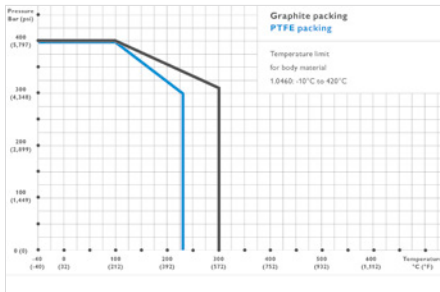
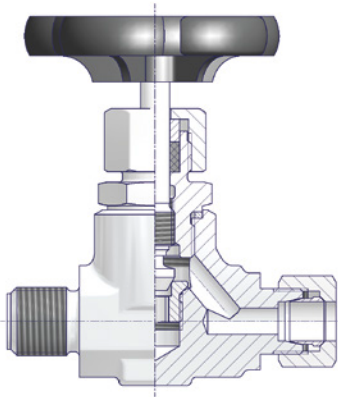

### S351 with External Stem Thread\*

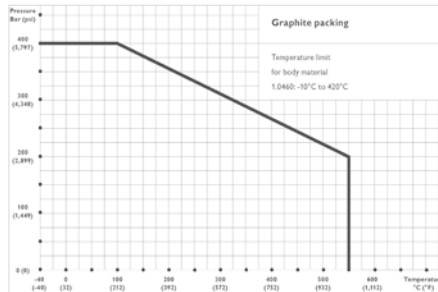
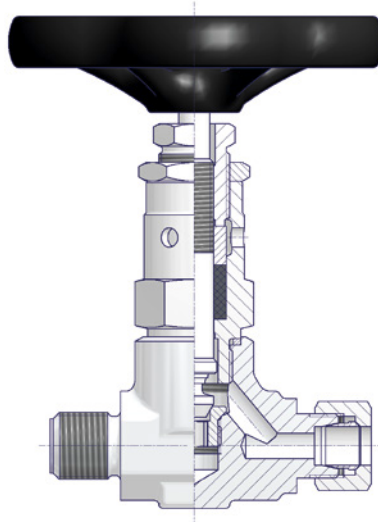

### F350 Bellows sealed option\*

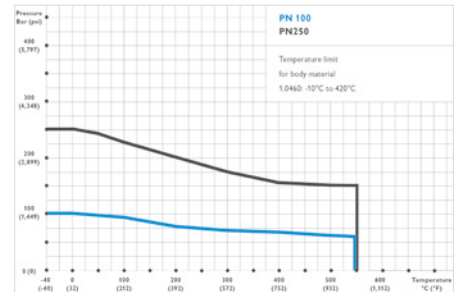
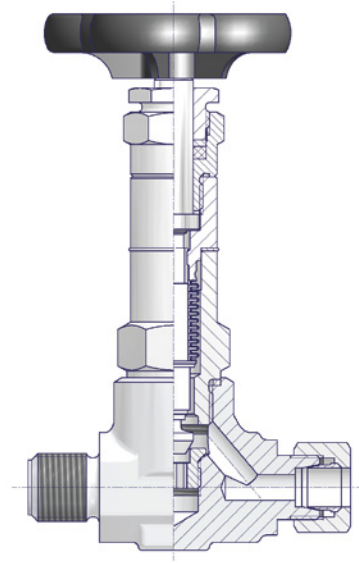

Components	Carbon Steel	Stainless Steel
	Material / Material No.	
Body	1.0460 / A105	
Bonnet	1.0501	
Valve Seat	1.4571	1.4571
Valve Stem	1.4104	
Needle Tip	1.4122	
Packing	PTFE (optional Graphite)	
Union Nut	Unalloyed Steel	1.4571
Tube Fittings		
Handwheel	Plastic	

Components	Carbon Steel	Stainless Steel
	Material / Material No.	
Body	1.0460 / A105	
Bonnet	1.7709	
Valve Seat	1.4571	1.4571
Valve Stem	1.4021	
Needle Tip	1.4122	
Packing	Graphite	
Stem Nut	Brass	1.4301
Union Nut	1.0501	1.4571
Single Ferrule	1.4571	
Handwheel	Unalloyed Steel	

Components	Carbon Steel	Stainless Steel
	Material / Material No.	
Body	1.0460 / A105	
Bonnet	1.0501	
Bellow	1.4571	1.4571
Valve Seat		
Valve Stem	1.4104	
Needle Tip	Stellite	
Packing	Graphite	
Stem Nut	1.4122	
Union Nut	1.0501	1.4571
Single Ferrule	1.4571	
Handwheel	Plastic	

\* Temperature limit for Carbon Steel -10°C to 420°C.  
Temperature limit for Single Ferrule Tube Fitting max. 400°C.

# Needle Valves Type S350

## Tube Fitting Connections Size S

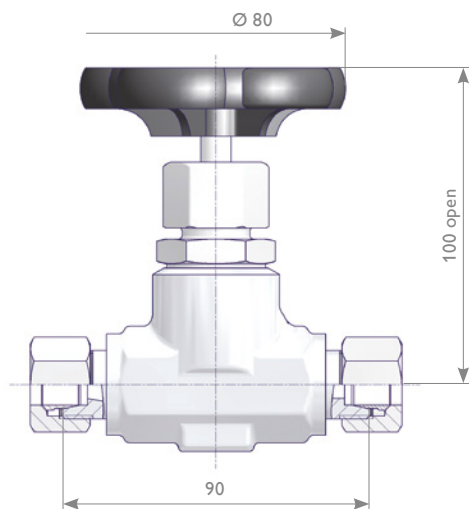

Inlet	Outlet	Material	Part Number
Tube Fitting Sizes			
12S		1.0460 / A105	S350.01.114
		1.4571	S350.01.214
14S		1.0460 / A105	S350.01.115
		1.4571	S350.01.215

## Threaded Connections

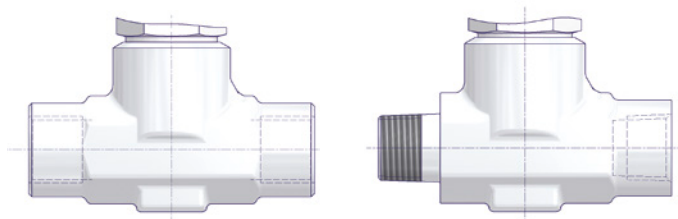

Inlet	Outlet	Material	Part Number
G 1/2 Female		1.0460 / A105	S350.03.104
		1.4571	S350.03.204
1/2 NPT Female		1.0460 / A105	S350.03.124
		1.4571	S350.03.224
1/2 NPT Male	1/2 NPT Female	1.0460 / A105	S350.07.124
		1.4571	S350.07.224

# Needle Valves Type S350

## Male Threads DIN 19207 / Tube Fitting Connection\*

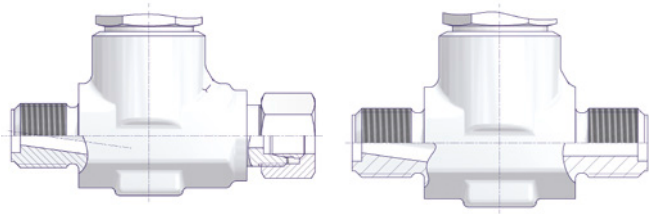

Inlet	Outlet	Material	Part Number
G 1/2 Male DIN 19207 – Type R	Tube Fitting Size 12S	1.0460 / A105	S350.07.114.06
		1.4571	S350.07.214.06
G 1/2 Male DIN 19207 – Type R		1.0460 / A105	S350.09.100.02
		1.4571	S350.09.200.02

\* Max. allowable (Working) Pressure (PS) PN 160.

## Weld Ends / Tube Fitting Connection

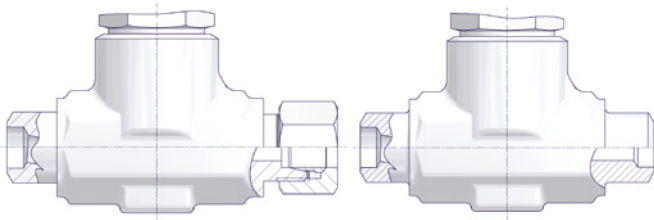

Inlet	Outlet	Material	Part Number
Weld End Ø 21.3 x Ø 12.2	Tube Fitting Size 12S	1.0460 / A105	S350.05.130
		1.4571	S350.05.230
Weld End Ø 21.3 x Ø 12.2		1.0460 / A105	S350.05.100
		1.4571	S350.05.200

# Needle Valves Type S351

## Tube Fitting Connections Size S

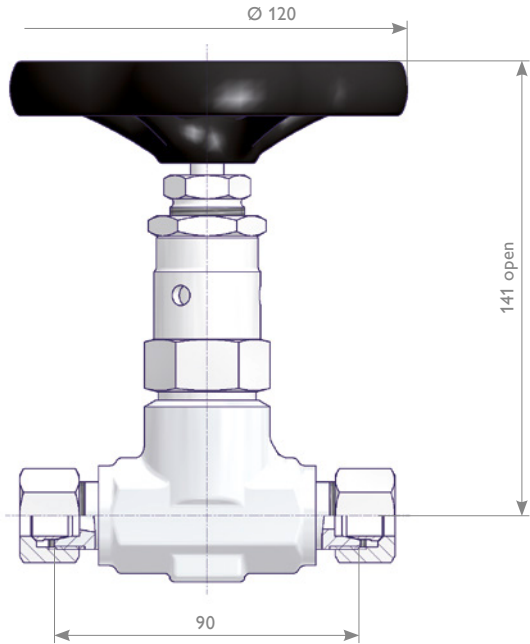

Inlet	Outlet	Material	Part Number
Tube Fitting Size			
12S		1.0460 / A105	S351.01.114
		1.4571	S351.01.214
14S		1.0460 / A105	S351.01.115
		1.4571	S351.01.215

## Threaded Connections

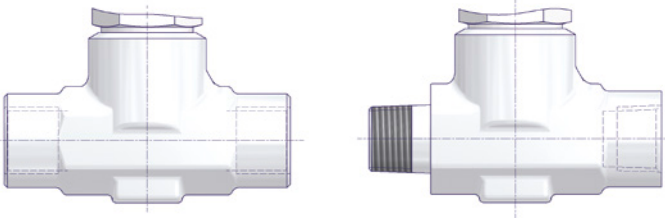

Inlet	Outlet	Material	Part Number
G 1/2 Female		1.0460 / A105	S351.03.104
		1.4571	S351.03.204
1/2 NPT Female		1.0460 / A105	S351.03.124
		1.4571	S351.03.224
1/2 NPT Male	1/2 NPT Female	1.0460 / A105	S351.07.124
		1.4571	S351.07.224

## Weld Ends / Tube Fitting Connection

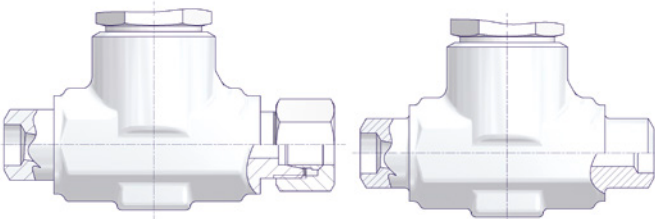

Inlet	Outlet	Material	Part Number
Weld End Ø 21.3 x Ø 12.2	Tube Fitting Size 12S	1.0460 / A105	S351.05.130
		1.4571	S351.05.230
Weld End Ø 21.3 x Ø 12.2		1.0460 / A105	S351.05.100
		1.4571	S351.05.200

# Angle Needle Valves Type S360

## Features

- Forged Body - DN 8 / Bore Size 8 mm
- Screwed Bonnet
- Integral Valve Seat
- Stem with cold rolled surface, back seat and non-rotating needle tip

Please contact the factory for Your Angle Pattern Needle Valve.

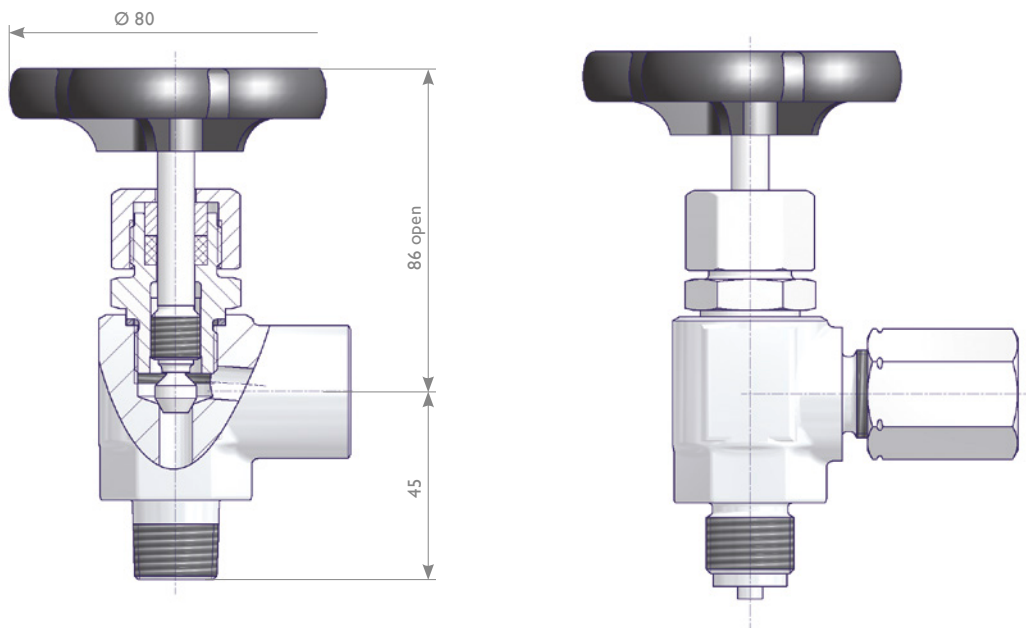

Components	Carbon Steel	Stainless Steel
	Material / Material No.	
Body	1.0460 / A105	1.4571
Bonnet	1.0501	
Valve Stem	1.4104	
Needle Tip	1.4122	
Packing	PTFE (Optional Graphite)	
Union Nut	Unalloyed Steel	1.4571
Tube Fitting		
Handwheel	Plastic	

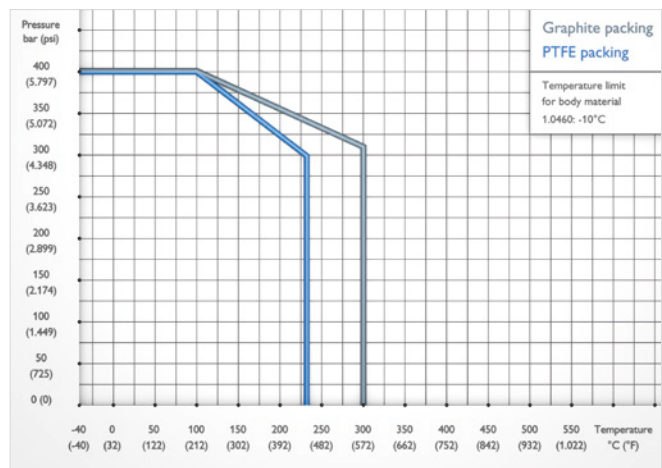

# Y-Pattern Needle Valves Type S371

## Features

- Forged Body - DN 8 / Bore Size 8 mm
- Screwed Bonnet
- Integral Valve Seat
- External Stem Thread
- Stem with cold rolled surface, back seat and non-rotating needle tip

Please contact the factory for Your Y-Pattern Needle Valve.

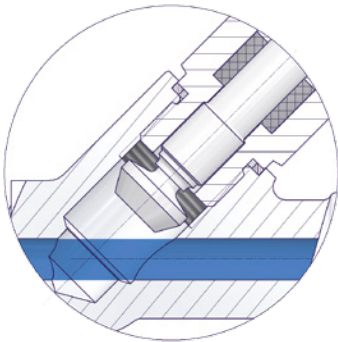

**Straight-Through Design**  
→ Valve is fully roddable

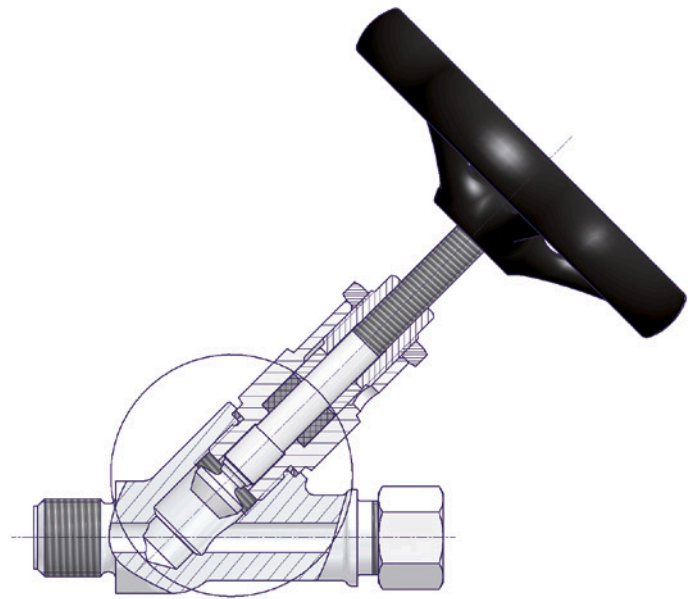

Components	Material / Material No.
Body	1.4571
Bonnet	
Valve Stem	
Needle Tip	
Packing	Graphite
Stem Nut	1.4301
Handwheel	Unalloyed Steel

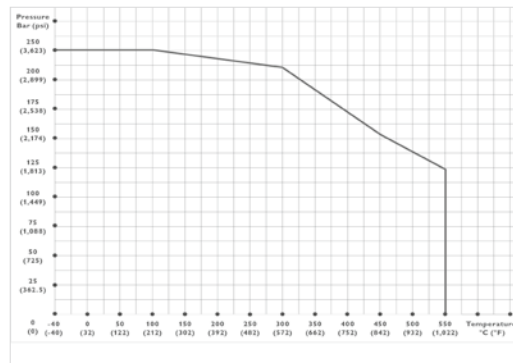

For Pressures exceeding 160 bar please contact the factory.

# Screwed Bonnet Needle Valves Type S340 / S381

## Features

- Forged Body - DN 8 / Bore Size 8 mm
- Screwed Bonnet
- Replaceable Valve Seat
- Stem with cold rolled surface, back seat and non-rotating needle tip

Needle Valve mainly used as Primary Isolation Valve.

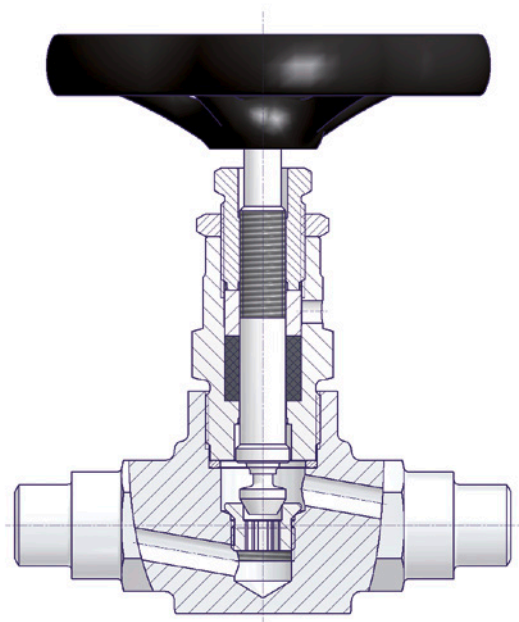

Components	Carbon Steel	Heat Resistant Steel		Stainless Steel
	Material / Material No.			
Body	1.0460 / A105	1.7335 / 1.5415	1.7383	1.4571
Bonnet	1.7709			
Valve Seat	1.4571		1.4981	
Valve Stem	1.4021		1.4571	
Needle Tip	1.4122		Stellite	
Packing	Graphite			
Stem Nut	Brass		1.4301	
Handwheel	Unalloyed Steel			

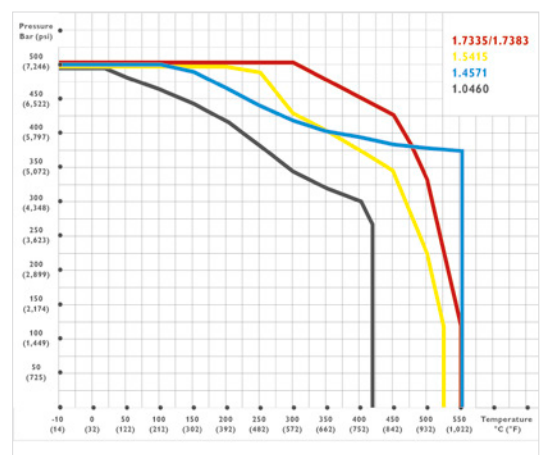

The respective max. allowable (Working) Pressure (PS) depends on the tube / pipe connection used. For further information please contact the factory.

# Screwed Bonnet Needle Valves

## Weld Ends

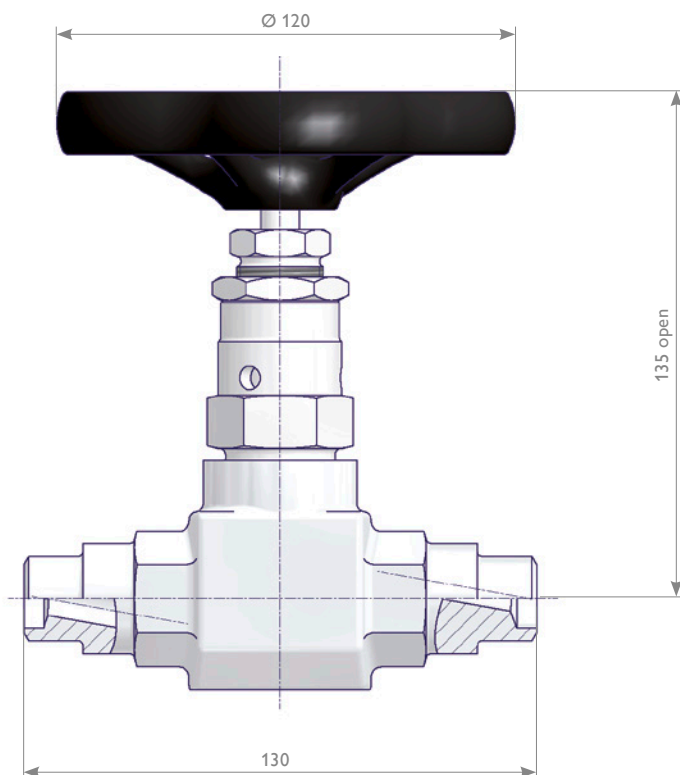

Weld End Connections		Part Number				
		Material				
Inlet	Outlet	1.0460 / A105	1.7335	1.5415	1.7383	1.4571
Tube Butt Weld End Ø 14 x 2.5		S340.11.112.04	S340.11.114.04	S340.11.600.11	S340.16.112.04	S340.11.212.04
Pipe Butt Weld End Ø 21.3 x 3.2		S340.11.135.31	S340.11.136.31	S340.11.636.31	S340.16.136.31	S340.11.236.31
Pipe Butt Weld End Ø 21.3 x 2.9		S340.11.135.32	S340.11.136.32	S340.11.636.32	S340.16.136.32	S340.11.236.32
Pipe Butt Weld End Ø 21.3 x 3.2	Tube Butt Weld End Ø 14 x 2.5	S340.11.135.33	S340.11.136.33	S340.11.636.33	S340.16.136.33	S340.11.236.33
Pipe Butt Weld End Ø 21.3 x 2.9	Tube Butt Weld End Ø 14 x 2.5	S340.11.135.34	S340.11.136.34	S340.11.636.34	S340.16.136.34	S340.11.236.34
Pipe Butt Weld End Ø 21.3 x 6.3	Tube Butt Weld End Ø 14 x 2.5	S340.11.135.37	S340.11.136.37	S340.11.636.37	S340.16.136.37	S340.11.236.37
Pipe Butt Weld End Ø 24 x 7.1	Tube Butt Weld End Ø 14 x 2.5	S340.11.135.40	S340.11.136.40	S340.11.636.40	S340.16.136.40	S340.11.236.40
Pipe Socket Weld End 1/2"		S381.40.114.01	S381.40.614.01	S381.40.714.01	S381.40.514.01	S381.40.214.01

# Union Bonnet Needle Valves Type A1

## Features

- Barstock Body - DN 11 / Bore Size 11 mm
- Union Bonnet
- Integral Valve Seat
- External Stem Thread
- Valve Stem with cold rolled threads
- Non-rotating Needle and back seat design

Options see Ordering Information on Page 23.

**Union Bonnet Needle Valves are designed for Severe Service.**

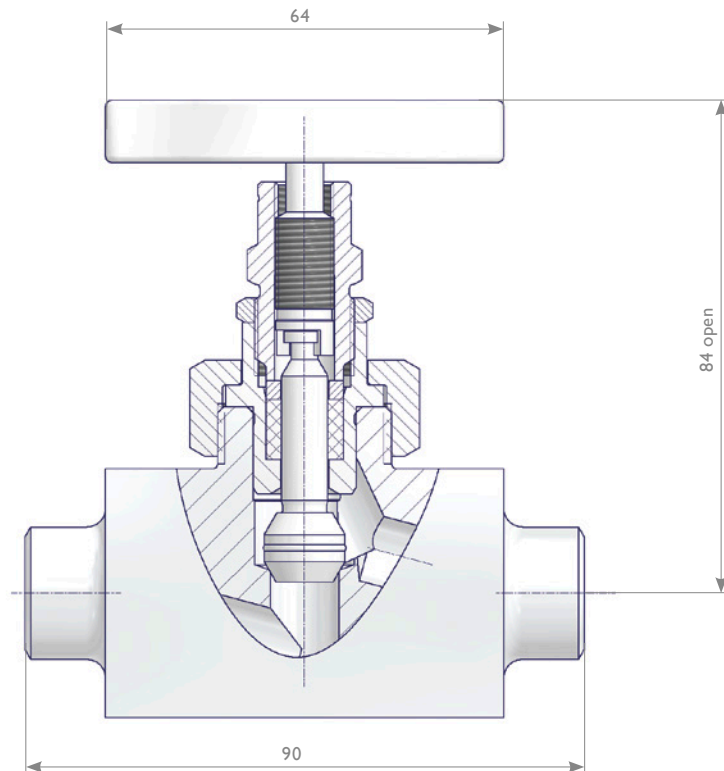

Components	Heat Resistant Steel	Stainless Steel
	Material / Material No.	
Body	1.4903 / F91*	316H
Bonnet	1.4903 / F91	316 / 316L
Valve Stem	1.4404 / 316L	
Needle	1.4923 - Tip Stellite	316 / 316L
Union Nut	1.7709	316 / 316L
Packing	PTFE or Graphite	
Stem Nut	316	
T Bar Handle	Options see Ordering Information	

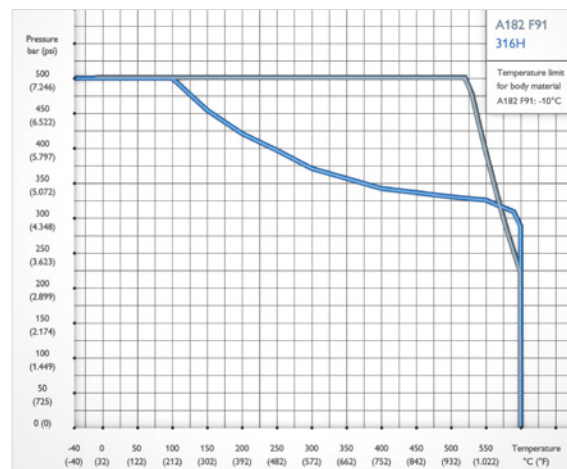

PTFE Packing is limited to 232°C (450°F).

The respective max. allowable (Working) Pressure (PS) depends on the tube / pipe connection used. For further information please contact the factory.

\* Welded connections in material 1.4903 / F91 / 1.7335 / 1.7380 require post weld heat treatment (PWHT) at around 700 - 750°C. The valve head unit must be removed prior to the heat treatment to avoid damages. See the installation, operation and maintenance manual for instructions. We recommend to order these valves with 100 mm pipe extensions (Option V - Box 15) to avoid the removal of the valve head units.

# Union Bonnet Tandem Valves Type B1

## Features

- Barstock Body DN 8 / Bore Size = 8 mm
- Union Bonnet
- Integral Valve Seat
- External Stem Thread
- Valve Stem with cold rolled threads
- Non-rotating Needle and back seat design

Options see Ordering Information on Page 23.

**Union Bonnet Tandem Valves are designed for Severe Service.**

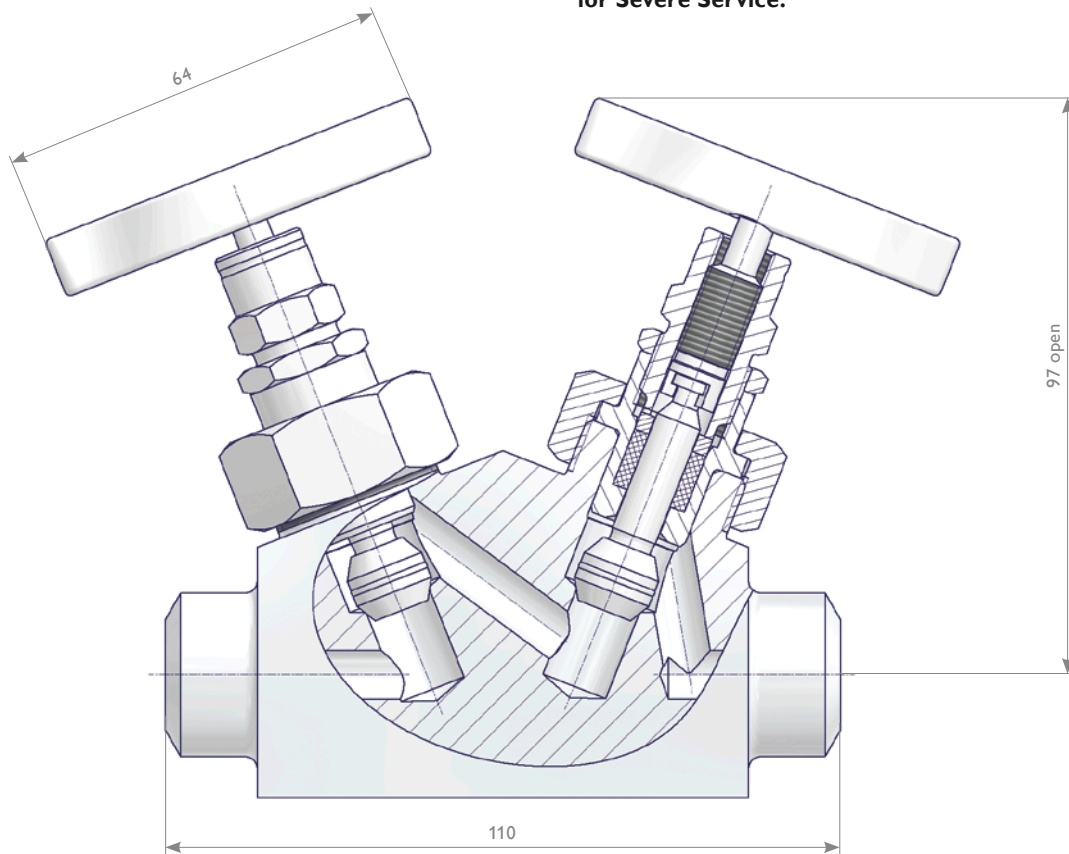

Components	Heat Resistant Steel				Stainless Steel
	Material / Material No.				
Body	1.4903 / F91*	1.5415	1.7335*	1.7380*	316 / 316L
Bonnet	1.4903 / F91				316 / 316L
Valve Stem	1.4404 / 316L				
Needle	1.4923 - Tip Stellite				316 / 316L
Union Nut	1.7709				316 / 316L
Packing	PTFE or Graphite				
Stem Nut	316				
T Bar Handle	Options see Ordering Information				

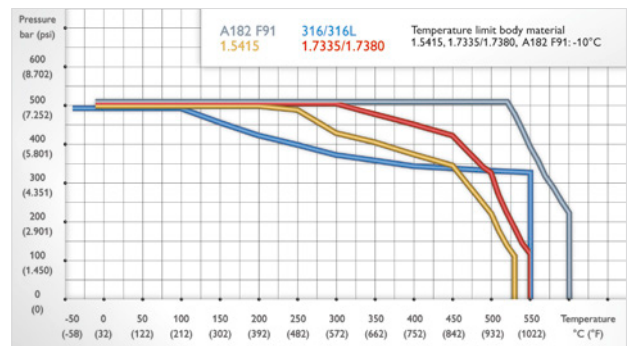

PTFE Packing is limited to 232°C (450°F).

The respective max. allowable (Working) Pressure (PS) depends on the tube / pipe connection used. For further information please contact the factory.

\* Welded connections in material 1.4903 / F91 / 1.7335 / 1.7380 require post weld heat treatment (PWHT) at around 700 - 750°C. The valve head unit must be removed prior to the heat treatment to avoid damages. See the installation, operation and maintenance manual for instructions. We recommend to order these valves with 100 mm pipe extensions (Option V - Box 15) to avoid the removal of the valve head units.

# Bolted Bonnet Needle Valves Type A2

## Features

- Barstock Body - DN 20 / Bore Size 20 mm
- Bolted Bonnet
- Integral Valve Seat
- External Stem Thread
- Valve Stem with cold rolled threads
- Non-rotating Needle and back seat design

Options see Ordering Information on Page 23.

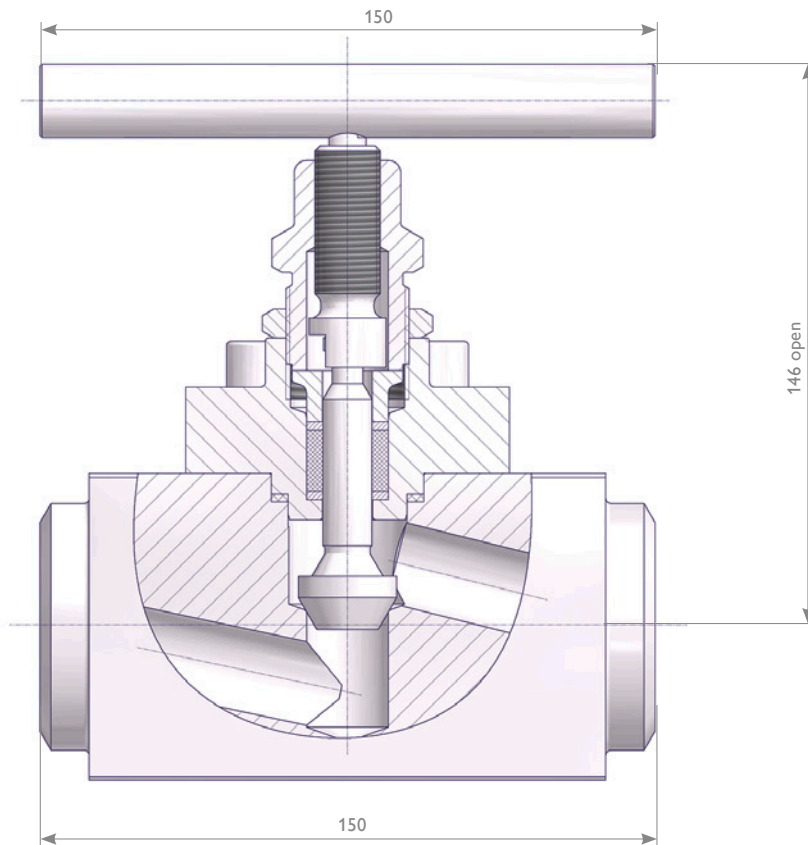

Components	Heat Resistant Steel	Stainless Steel
	Material / Material No.	
Body	1.4903 / F91	316 / 316L
Bonnet	1.4903 / F91	316 / 316L
Body-Bonnet Seal	Graphite	
Valve Stem	S17400	
Needle	1.4923 - Tip Stellite	316 / 316L
Bonnet bolting	1.4980 / A453 Gr.660 Cl.B	
Packing	PTFE or Graphite	
Stem Nut	1.4301 / 304	
T Bar Handle	Options see Ordering Information	

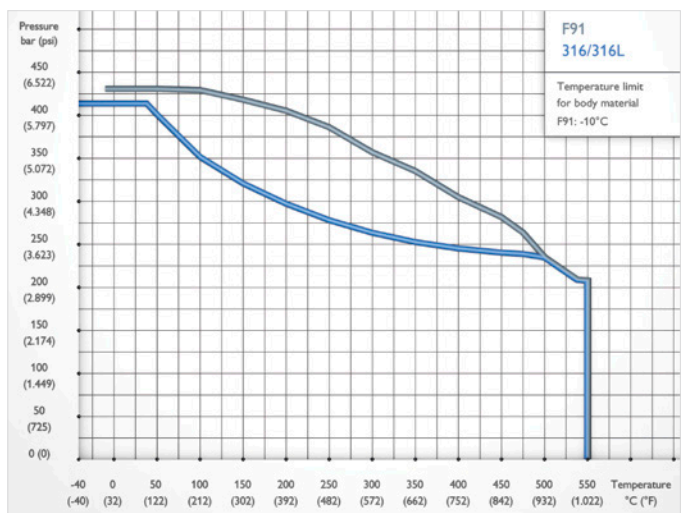

PTFE Packing is limited to 232°C (450°F).

The respective max. allowable (Working) Pressure (PS) depends on the tube / pipe connection used. For further information please contact the factory.

# Welded Bonnet Needle Valves Type A4

## Features

- Barstock Body - DN 10 / Bore Size 10 mm
- Electron Beam Welded Bonnet
- Extended Bonnet to dissipate heat and to lower heat at the packing and the stem threads
- Integral Valve Seat
- External Stem Thread
- Valve Stem with cold rolled threads
- Non-rotating Needle and back seat design

Options see Ordering Information on Page 23.

## Needle Valve for High Temperature Service.

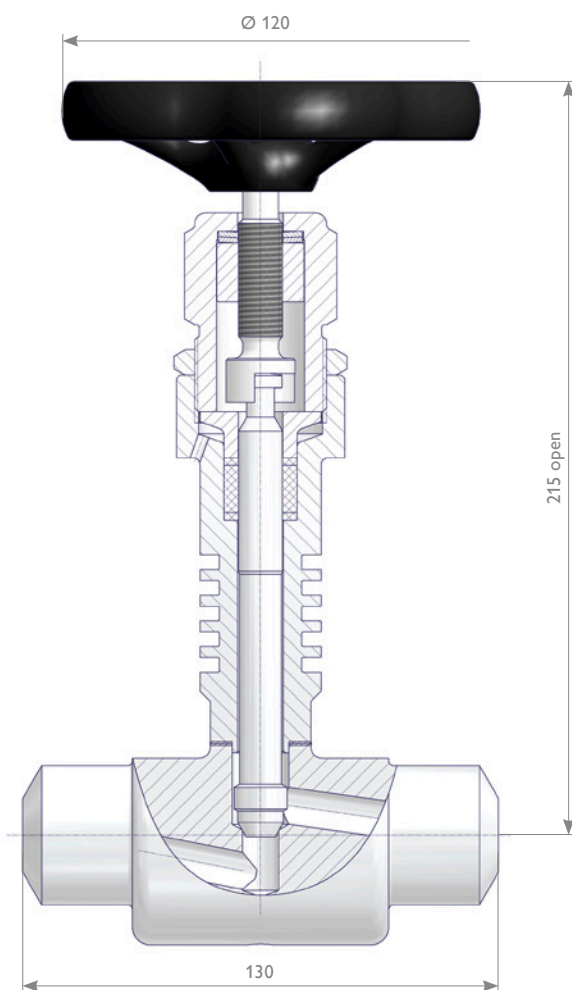

Components	Heat Resistant Steel	Stainless Steel
	Material / Material No.	
Body	1.4901	1.4981
Bonnet	1.4901	1.4981
Valve Stem	1.4923	
Needle	Alloy 80A	
Packing	Graphite	
Stem Nut	1.4571	
T Bar Handle	Options see Ordering Information	

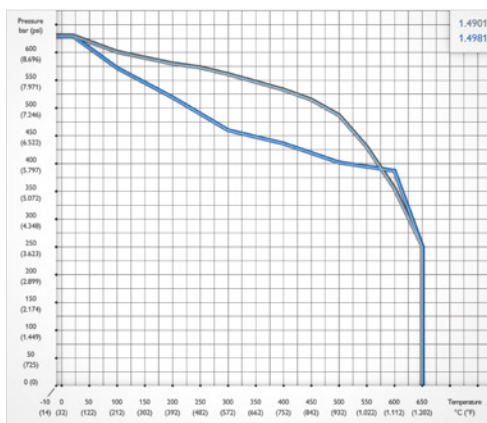

Graphite Packing only.

# Ordering Information I A1, B1, A2 and A4 Needle Valves

## Ordering Information

				1	2	3	4	5	6	7	8	9	10	11	12	13	14	15	
				B	1	B	-	A	4	P	A	4	P	-	S	A	K		
<b>Valve Type</b>																			
A1	Union Bonnet Needle Valve DN 11 / Bore Size 11 mm																		
B1	Union Bonnet Tandem Valve DN 8 / Bore Size 8 mm																		
A2	Bolted Bonnet Needle Valve DN 20 / Bore Size 20 mm																		
A4	Welded Bonnet Needle Valve DN 10 / Bore Size 10 mm (Graphite Packing only.)																		
<b>Packing</b>																			
A	PTFE																		
B	Graphite																		
W	Carbon-Filled PTFE – TA-Luft																		
<b>Inlet Connection</b>																			
A	Butt Weld End																		
D	Socket Weld End																		
H	Twin Ferrule Tube Fitting																		
L	Female Thread																		
<b>Pipe / Tube</b>				<b>Tube Fitting</b>				<b>Thread</b>											
4	1/2" pipe			R	Rotarex			N	NPT										
6	3/4" pipe*1			S	Swagelok														
8	1" pipe*1																		
C	10 mm																		
D	12 mm																		
E	14 mm																		
F	16 mm																		
G	18 mm																		
K	25 mm*1																		
T	1" tube*1																		
V	1 1/4" tube*1																		
X	1 1/2" tube*1+2																		
<b>Wall Thickness Pipes / Tubes</b>				<b>Tube O.D.</b>				<b>Thread Size</b>											
2	2.0 mm			4	12			4	1/2"										
3	3.2 mm			5	14														
4	4.0 mm			6	16														
8	2.6 mm																		
A	3.6 mm																		
D	5.0 mm																		
E	5.5 mm																		
G	7.0 mm																		
N	Schedule 40																		
P	Schedule 80																		
Q	Schedule 160																		
A	Socket Weld																		
<b>Outlet Connection → see Inlet Connection Ordering Information Specifics</b>																			
<b>Body Material</b>																			
	<b>A1</b>	<b>B1</b>	<b>A2</b>	<b>A4</b>															
R	-	1.7335	-	-															
S	316H	316/316L	316/316L	-															
U	-	1.7380	-	-															
W	F91	F91	F91	-															
Q	-	1.5415	-	-															
X	-	-	-	1.4981															
Y	-	-	-	1.4901															
<b>Vent Connection</b>																			
A	Without																		
<b>Operation Options</b>																			
B	Handwheel Unalloyed Steel: Standard Option for Needle Valves Type A4																		
K	T Handle: Standard Option for Needle Valves Type A1, B1 and A2																		
<b>Additional Options</b>																			
V	Pipe Extension																		

\*1 Socket Weld End for A2 Needle Valve only.

\*2 Butt Weld End not available for A1 Needle Valve.

Armaturenfabrik Franz Schneider GmbH + Co.KG reserves the right to change materials, specifications or designs without notice.

# Condensate Pots

## Product Description

Condensate Pots (also called Seal Pots) are used in the measurement of steam or other vapors for two reasons: One reason is that a level of condensed water is accumulated inside of the pot and maintains a fluid volume for displacement equal to or greater than the volume displacement of the transmitter (protecting the transmitter from heat).

The second reason for maintaining a liquid inside of the pot is to prevent flashing of the liquid in the impulse line if a sudden temperature change of the steam is made. A dam inside of the pot prevents this flashing effect.

Pots with more outlet ports for applications where foreign material should be trapped and drained preventing damage of the manifolds and transmitters are also available.

For more details please contact the factory. For details see also DIN 19211.

## Condensate Pots for Small Volume Displacements

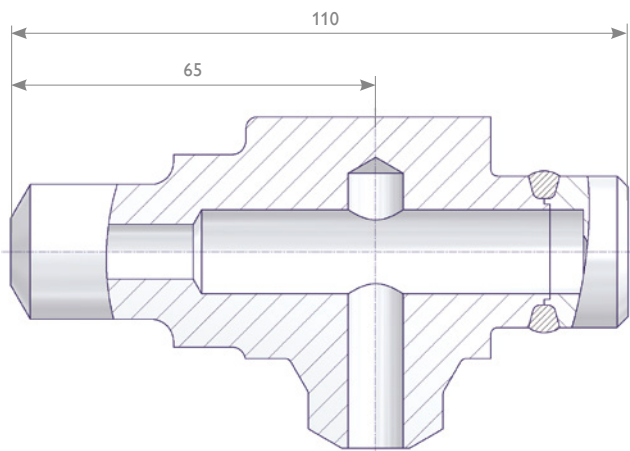

### Optional

Condensate Pot / Primary Isolation Valve Assembly - Factory Welded

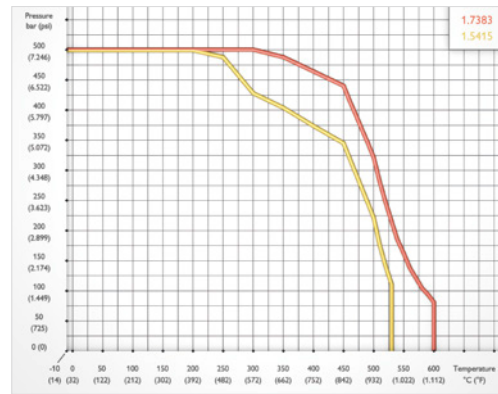
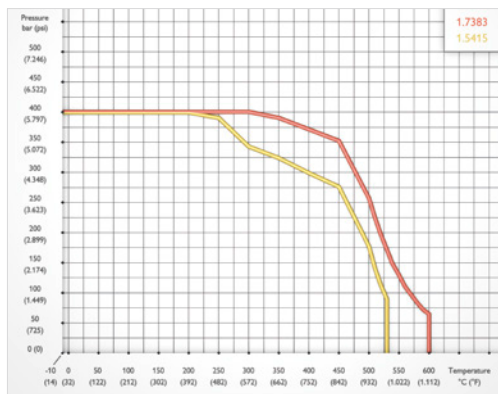
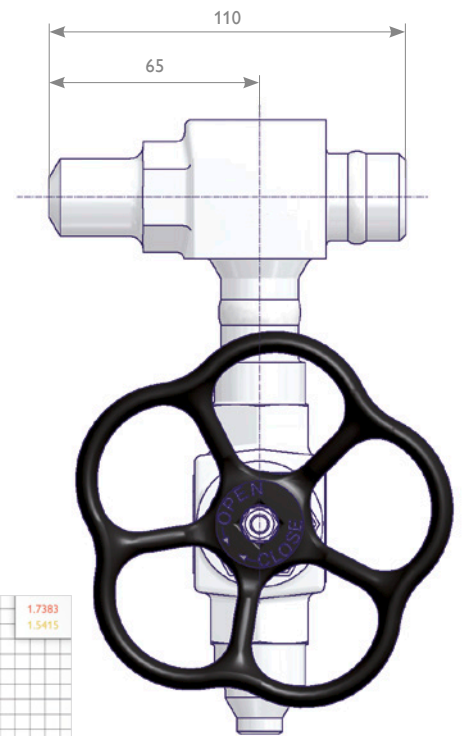

Weld End Connections		Part Number		
		Material		PN
Inlet	Outlet	1.5415	1.7383	
		Volume (approx.) 20 cm <sup>3</sup>		
Pipe Butt Weld End Ø 21.3 x 3.2		400	S007.51.603.42	
Pipe Butt Weld End Ø 21.3 x 6.3		500	S007.51.600.45	
Pipe Butt Weld End Ø 24 x 7.1		500	S007.51.600.26	S007.51.500.26

## Condensate Pots for Larger Volume Displacements

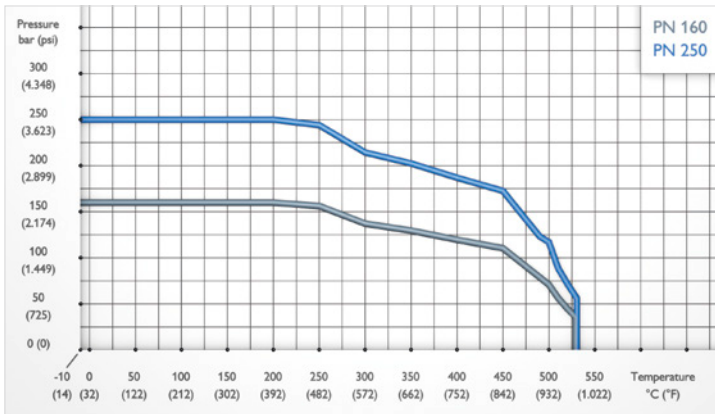
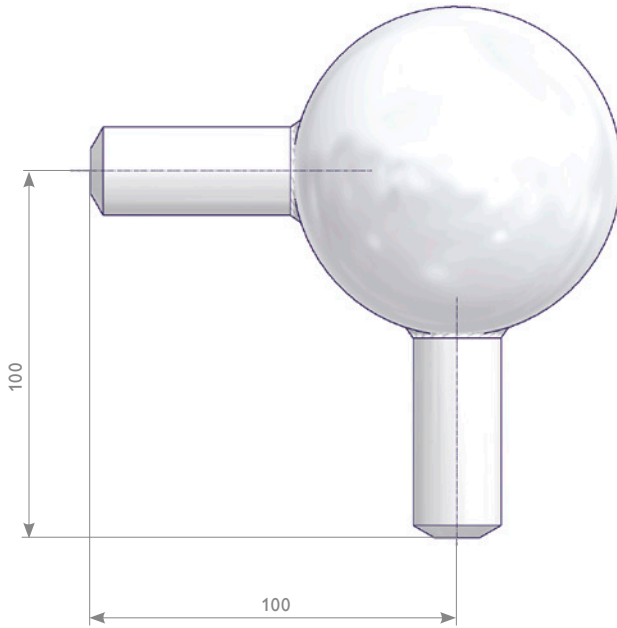

Weld End Connections		Part Number		
		Material 1.5415		
Inlet	Outlet	PN	Volume	
			250 cm <sup>3</sup>	700 cm <sup>3</sup>
Pipe Butt Weld End Ø 21.3 x 6.3		250	S007.51.653.05	
Pipe Butt Weld End Ø 33.7 x 4.5	Pipe Butt Weld End Ø 24 x 7.1	250		S007.51.653.06
G 1/2 Male DIN 19207 Type R	G 1/2 Male DIN 19207 Type V	160	S007.51.653.04	

# Weld Fittings | Tees, Reducers, Connectors

## Product Description

AS-Schneider is providing a large range of Weld Fittings – different concerning shape (Tees, Elbows, etc.) and connections (for pipes and tubes) and different in terms of available materials. On this page we are just showing the most used types.

If you don't find your option please contact the factory.

## Tees

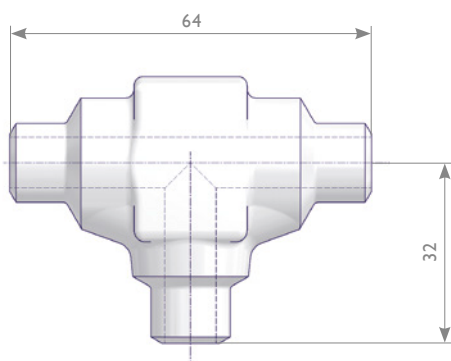

Weld End Connections	Part Number		
	Material		
	1.5415	1.7335	1.4571
Pipe Butt Weld End Ø 21.3 x 3.2	S006.40.610.43		S006.40.210.43
Tube Butt Weld End Ø 14 x 2.5	S006.40.600	S006.40.101	S006.40.200
Tube Socket Weld End Ø 12			S006.40.210

## Reducers (Pipe Butt Weld x Tube Butt Weld)

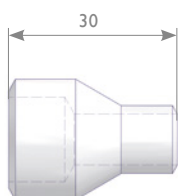

Weld End Connections		Part Number	
		Material	
		1.5415	1.4571
Pipe Butt Weld End Ø 21.3 x 3.2	Tube Butt Weld End Ø 12 x 1.5		S006.40.230.20
Pipe Butt Weld End Ø 21.3 x 3.2	Tube Butt Weld End Ø 14 x 2.5	S006.40.630.14	S006.40.230.14
Pipe Butt Weld End Ø 33.7 x 4.5	Tube Butt Weld End Ø 14 x 2.5	S006.40.632.84	S006.40.232.84

## Connectors (Pipes and Tubes)

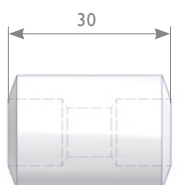

Weld End Connections	Part Number	
	Material	
	1.5415	1.4571
Weld End Ø 21.3 x Ø 12.2		S006.40.220
Weld End Ø 21.3 x Ø 14.25	S006.40.120.04	S006.40.220.04

# Threaded Pipe Ends acc. to DIN 19207

## Product Description

DIN 19207 is defining 2 different Threaded Connections (Type V and Type R) to be used either for a Flanged Connection with Threaded Flanges or a Nipple Connection. For more details see DIN 19207. The max. allowable (Working) Pressure (PS) for this connection is defined at 160 bar.

Valves with DIN 19207 connections see Page 13, condensate pots see Page 25.

## Flange Connection I Accessory Kit

Mounting Kit contains	Material	Part Number
4 Hexagon Nuts DIN EN ISO 4032 - M10	Carbon Steel Nuts and Screws 1.1181, Gasket 1.4571, Flange 1.0460	S006.39.100.02
4 Hex Cap Screws DIN EN ISO 4014 - M10 x 45		
1 Grooved Gasket DIN 19207 - B 1/2	Stainless Steel Nuts A4-70, Screws A2-70, Gasket 1.4571, Flange 1.4571	S006.39.200.02
2 Threaded Flanges DIN 19207 - G 1/2		

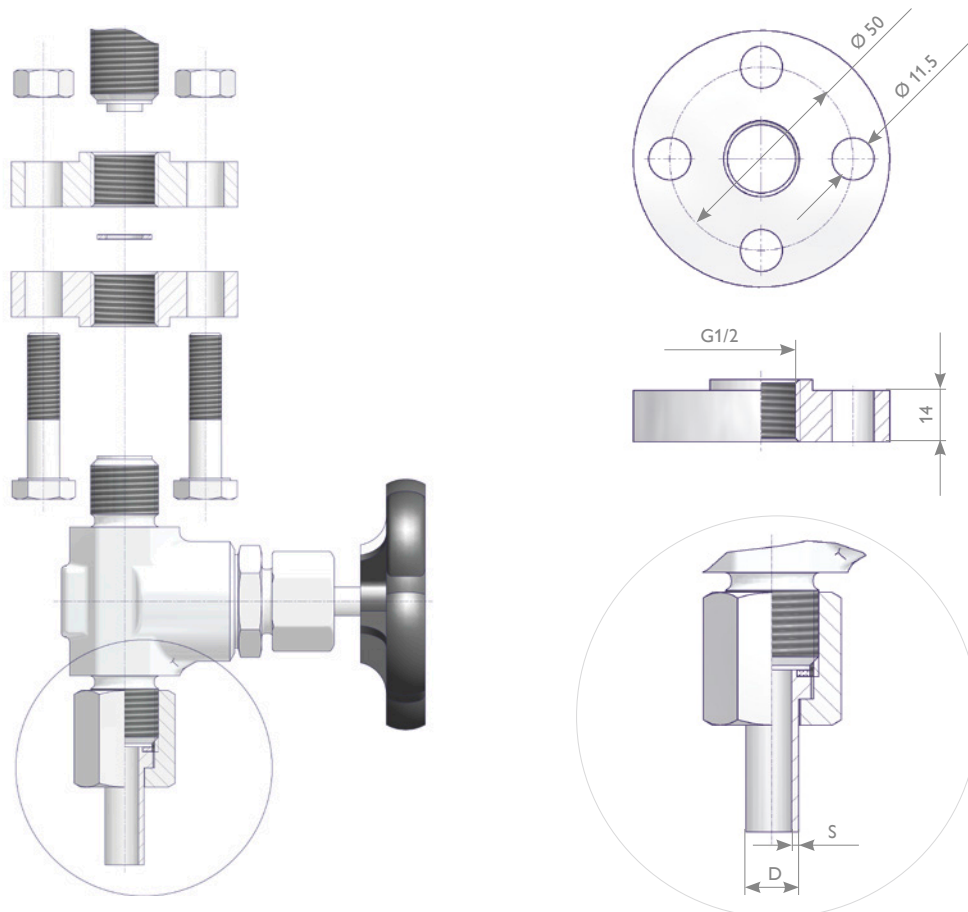

## Nipple Connection I Accessory Kit

Union Nut		Nipple		Grooved Gasket	Accessory Kit
Thread	Material	D	s	Material	Part Number
G 1/2	1.1181	12	1.65	1.5415	S007.45.103.10
	1.4571			1.4571	S007.45.203.10
	1.1181	14	2.5	1.5415	S007.45.103.11
	1.4571			1.4571	S007.45.203.11

# YOUR GLOBAL PARTNER

for Instrumentation and  
Double Block & Bleed Valves



Visit us on:



ARMATURENFABRIK FRANZ SCHNEIDER GMBH + CO. KG  
World Headquarters  
Bahnhofplatz 12, 74226 Nordheim, Germany  
Tel: +49 7133 101-0  
[www.as-schneider.com](http://www.as-schneider.com)



ARMATURENFABRIK FRANZ SCHNEIDER SRL  
Gradinari 32-38, 100404 Ploiesti  
Romania  
Tel: +40 244 384 963  
[www.as-schneider.ro](http://www.as-schneider.ro)



AS-SCHNEIDER ASIA-PACIFIC PTE. LTD.  
970 Toa Payoh North, #02-12/14/15, Singapore 318992,  
Singapore  
Tel: +65 62 51 39 00  
[www.as-schneider.sg](http://www.as-schneider.sg)



AS-SCHNEIDER AMERICA, INC.  
17449 Village Green Dr, Houston, TX 77040  
United States of America  
Tel: +1 281 760 1025  
[www.as-schneider.com](http://www.as-schneider.com)



AS-SCHNEIDER MIDDLE EAST FZE  
P.O. Box 18749, Dubai  
United Arab Emirates  
Tel: +971 4 880 85 75  
[www.as-schneider.ae](http://www.as-schneider.ae)



AS-1001-EN | March 2020